

RETROAIRE

The Right Fit for Comfort

RC 50 PACKAGED TERMINAL AIR CONDITIONER

P/N# 240004382, Rev. 1.1 [02/05]

SPECIFICATIONS AND PERFORMANCE

Replacement for
**Dunham/Bush Newport
Models I, II, III, and IV**

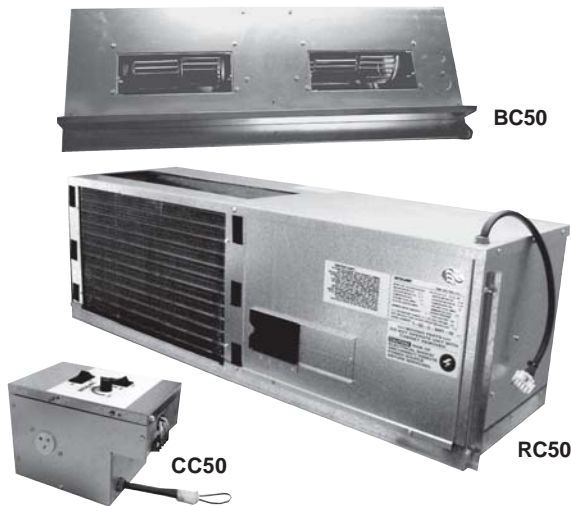

Straight Cool

Nominal Capacities:
9,000 - 12,000 - 15,000 & 18,000 Btuh

PRODUCT DESCRIPTION

The RetroAire RC50 is a packaged terminal air conditioner designed to allow owners of Dunham/Bush Newport models I, II, III, IV to upgrade the performance of their room air conditioning and achieve significant efficiency improvement.

This unit is available as a cooling-only model and energy efficiency ratings as high as 9.0 can mean rapid pay-back of your replacement investment through energy savings.

The RC50 features two fan speeds and a manual fresh air damper. Because the outdoor fan is separate, it does not run in venting or supplemental heating modes, thereby saving energy. Whisper quiet operation improves room ambience and a washable, permanent filter makes service a snap. The 20 gauge galvanized steel construction of the chassis ensures long service life.

All Retroaire products are backed by Enviromaster International LLC and are tested and rated in accordance with ari standards 310 & 380 and UL 484. A full service parts inventory is always available.

▲ Air System:

- Motors are PSC type with overheat protection.
- Blower deck air stream surfaces are insulated with 1/4" fiberglass or 1/8" Volara™.
- Filter is washable, permanent, and accessible without tools.

▲ **High Efficiency Heat Exchanger** – Coil is seamless rifled copper tubing arranged in staggered configuration with enhanced aluminum fins and tested to 400 psig. The tubes are mechanically expanded for secure bonding to fin shoulders.

▲ Refrigeration Circuit:

- High efficiency rotary compressor with a five year warranty (standard)
- Automatic expansion valve for low-ambient protection, allows cooling down to 35° F.

▲ Factory Supplied Controls And Components:

- Unit Mounted Operating Controls
 - Thermostat
 - Fan Speed Control
 - Heat/Cool System Switch
- Continuous/Cycling Fan Control Switch (unit mount only)
- Manual Fresh Air Damper (RC50 chassis)
- Weather Strip Insulation
- Condenser Duct Kit (field specified and installed)
- Sea Coast Coated Drain Pans

IMPORTANT: To ensure proper duct supply, duct depth should be identified prior to ordering.

▲ Optional Controls And Components:

- Electric Heat (field installed)
- 24V Remote Thermostat
- Hydronic Heat Coil (single row)
- Hydronic Coil Freeze Protection
- 2 or 3-Way Water Valve
- Sea Coast Coated Coils

▲ **Warranty** – All RetroAire products are covered under standard warranty and are backed by Enviromaster International, LLC.

RC50 SPECIFICATIONS AND PERFORMANCE DATA

NOTE: Due to ongoing product development, design, specifications, and performance data may change without notice.

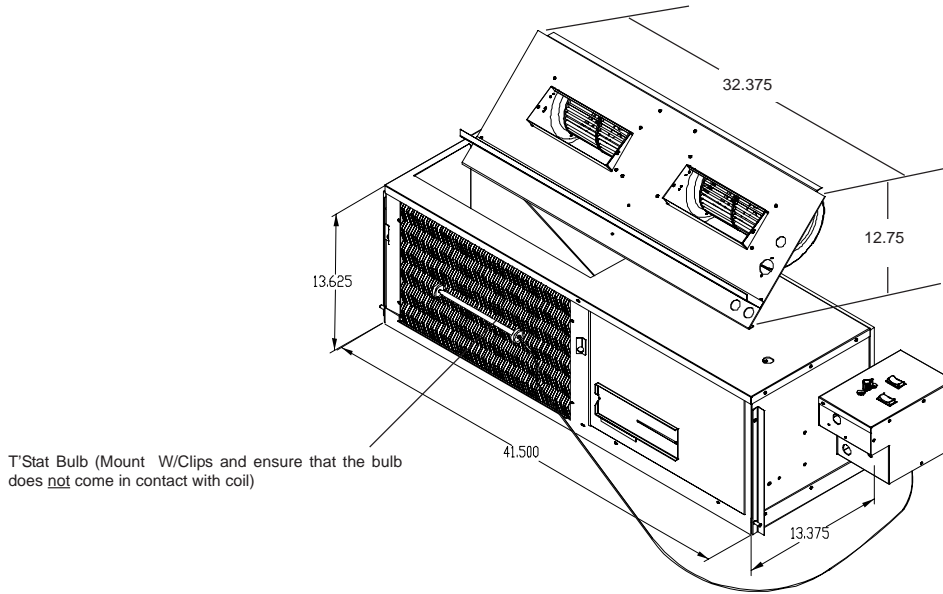

RC50 PERFORMANCE DATA				
UNIT SIZE	COOLING BTUH	EER	EVAP CFM HI/LO	FRESH AIR CFM
09	9,200	9.0	385/335	40/35
12	11,100	8.8	385/335	40/35
15	13,700	8.5	440/385	55/45
18	16,300	8.2	440/385	55/45

RC50 ELECTRICAL SPECIFICATIONS												
MODEL NUMBER	VOLTS/HZ/PH ASE	EVAP MOTOR		COND MOTOR		COMPRESSOR		TOTAL AMPS	MCA	MAX FUSE	MIN VOLTS	LINE CORD
		FLA	HP	FLA	HP	RLA	LRA					
09	115/60/1	1.4	0.09	1.25	0.1	7.4	44	10.1	11.9	15	104	5-15P
	208/230/60/1	0.6	0.08	0.71	0.09	3.8	20	5.1	6.1	15	197	6-15P
	265/60/1	0.67	0.08	0.71	0.09	3.3	18.6	4.7	5.5	15	240	7-20P
12	115/60/1	1.4	0.09	1.25	0.1	9.7	54	12.4	14.8	20	104	5-20P
	208/230/60/1	0.6	0.08	0.71	0.09	4.8	26.3	6.1	7.3	15	197	6-15P
	265/60/1	0.67	0.08	0.71	0.09	4.2	28	5.6	6.6	15	240	7-20P
15	208/230/60/1	0.6	0.08	0.71	0.09	6.4	38	7.7	9.3	15	197	6-15P
	265/60/1	0.67	0.08	0.71	0.09	5.4	32	6.8	8.1	15	240	7-20P
18	208/230/60/1	0.6	0.08	0.71	0.09	7.6	45	8.9	10.8	15	197	6-15P
	265/60/1	0.67	0.08	0.71	0.09	6.3	32	7.7	9.3	15	240	7-20P

RC50 OPTIONAL ELECTRIC HEAT SPECIFICATIONS							
HEATER NO.	VOLTAGE	WATTS	BTUH	AMPS	TOTAL HEAT AMPS	MCA	MAX FUSE
3	208	3,200	11,000	15.4	16.0	19.8	20
	230	3,900	13,400	17.0	17.6	21.8	25

NEMA Specifications Non-Locking/Receptacles								
VOLTAG PLUG RECEPTACLE	125V		250V			265V		
	15(A)	20(A)	15(A)	20(A)	30(A)	15(A)	20(A)	30(A)
	5-15 P	5-20 P	6-15 P	6-20 P	6-30 P	7-15 P	7-20 P	7-30 P
	5-15 R	5-20 R	6-15 R	6-20 R	6-30 R	7-15 R	7-20 R	7-30 R

An ECR International Brand
ENVIROMASTER INTERNATIONAL LLC
 5780 Success Dr., Rome, NY 13440
 Phone: 1-800-228-9364
 FAX: 1-800-232-9364
 Email: info@retroaire.com