

RETROAIRE

The Right Fit for Comfort

RC/RH45 PACKAGED TERMINAL AIR CONDITIONER/HEAT PUMP

P/N# 240004377, Rev. 1.2 [02/05]

Replacement for
**AMERICAN STANDARD
REMOTAIRE TYPE 40**

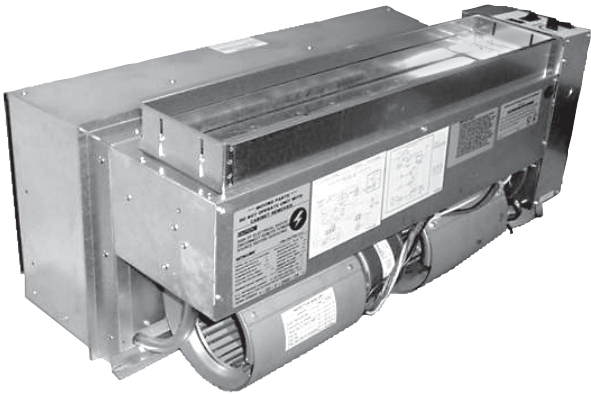

Cooling Only/Heat Pump

Nominal Capacities: 9000,
12,000, 15,000, and 18,000 Btuh

PRODUCT DESCRIPTION

The RetroAire RC/RH45 replacement chassis is a conditioner designed to allow owners of American Standard Remotaire Type 40 and other packaged terminal units to upgrade room comfort while reducing costs through higher efficiency and enhanced reliability.

This unit is available as a cooling-only model, and for those who wish to upgrade to a heat pump, the RH45 chassis will also fit the existing wall sleeve. This heat pump version will reduce heating energy costs at outdoor temperatures as low as 35°F (available in 9,000-15,000 Btuh only).

Energy Efficiency Ratings run as high as 10.0, which can mean rapid payback of your replacement investment through energy savings. The RetroAire RC/RH45 features two fan speeds. Its separate outdoor fan does not run in venting or electric heat modes, thereby saving energy.

Whisper-quiet operation improves room ambiance and the chassis is 20 gauge, galvanized steel construction ensures long service life.

All RetroAire products are backed by EMI and by ECR International and are tested and rated in accordance with ARI Standards 310 & 380 and UL 484. A full service parts inventory is always available.

▲ Air System:

- Forward-curved type fans, directly mounted to motor shafts.
- PSC type motors with over heat protection.
- ¼" fiberglass insulated air-stream surfaces.

▲ **High Efficiency Heat Exchanger** – Coil is seamless, rifled copper tubing, arranged in staggered configuration, with enhanced aluminum fins, tested to 400 psig. The tubes are mechanically expanded for secure bonding to fin shoulders.

▲ Refrigeration Circuit:

- High efficiency, rotary compressor with 5 year warranty standard.
- Automatic expansion valve refrigerant metering for low-ambient cooling protection, allows cooling down to 35°F.

▲ Heat Pumps:

- Heat pump heating operates as low as 40°F outdoor temperature.
- Heat pumps include a changeover thermostat with emergency heat position.
- A temperature actuated drain pan valve for heat pump condensate disposal is included to protect the motor and fan.

▲ Accessories:

- Motorized fresh air damper with positive-pressure seal and override switch.
- Continuous/cycling fan control switch.
- Electric heat at 3, 4, or 5KW.
- For hydronic heat (consult the factory for 1 or 2 row hydronic heat coil)
- Remote thermostat.
- Filter (contact factory for specifics)
- Custom sleeves kits*

**The RC/RH45 is designed to fit the existing sleeve kit of the old unit, new sleeves can be provided if it is necessary to replace the existing sleeve due to rust or damage.*

Wall Thickness

The distance from the condenser coil to the outdoor louver varies with sleeve depth; unit(s) ship standard with 1 3/8" & 1 1/2" baffles. In addition, EMI stocks an optional condenser-side air baffle kit for chassis installation in deeper-than-standard wall sleeves. For fast, trouble-free installation, know your wall sleeve depth when ordering.

RC/RH45 Dimensions and Specifications

NOTE: *Due to EMI's ongoing development programs, design, specifications, and performance data may change without notice.
 ** For more detailed Hydronic Heat performance information check our web site www.retroaire.com

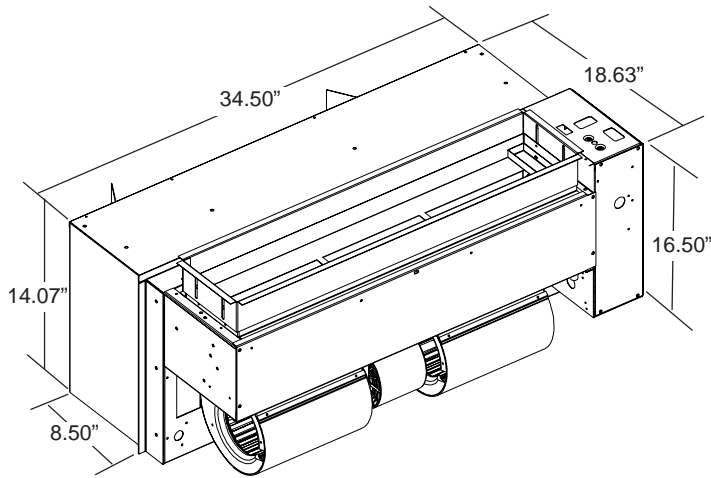

RC/RH45 PERFORMANCE DATA*						
Unit Size	Cooling Btuh	EERs	Heat Pump Btuh	COP	Evaporator CFM Hi/Lo	Fresh Air CFM
9	9,500	10	8500	2.8	440/340	40/35
12	11,900	10	11400	2.9	440/340	40/35
15	14,700	9.2	13800	2.8	500/440	40/35
18	16,900	9.1	N/A	N/A	500/440	40/35

RC/RH45 Optional Electric Heat Specifications								
Heater No.	Voltage	Watts	Btuh	Amps	Total Heat Amps	MCA	Max Fuse	Line Cord
2	208	1,636	5,600	7.9	8.5	10.4	15	6-15P
	230	2,000	6,900	8.7	9.3	11.5	15	6-15P
	265	2,655	9,100	10	10.7	13.2	15	7-20P
3	208	2,454	8,400	11.8	12.4	15.3	20	6-20P
	230	3,000	10,300	13	13.6	16.9	20	6-20P
	265	3,983	13,600	15	15.7	19.5	20	7-20P
4	208	3,271	11,200	15.7	16.3	20.3	25	6-30P
	230	4,000	13,700	17.4	18	22.3	25	6-30P
	265	5,310	18,200	20	20.7	25.7	30	7-30P
5	208	4,089	14,000	19.7	20.3	25.2	30	6-30P
	230	5,000	17,100	21.7	22.3	27.8	30	6-30P

RC/RH45 Hydronic Heat ** Performance 104-130 (Single Row Coil)			
GPM	EWT (°F)	Capacities	P.D.
3.0	180°F Hi	11,948	2.6
	180°F Lo	11,227	2.6
	140°F Hi	7,526	2.6
	140°F Lo	7,077	2.6

RC/RH45 Hydronic Heat ** Performance 104-305 (Double Row Coil)			
GPM	EWT (°F)	Capacities	P.D.
3.0	180°F Hi	25,407	1.4
	180°F Lo	23,858	1.4
	140°F Hi	15,884	1.4
	140°F Lo	14,935	1.4

RC/RH45 Electrical Specifications												
Model Number	Voltage/Hz/Phase	Evap Motor		Cond Motor		Compressor		Total Amps	MCA	Max Fuse	Min Voltage	Line Cord
		FLA	HP	FLA	HP	RLA	LRA					
9	115/60/1	1.4	0.09	1.6	0.125	7.4	44	10.4	12.3	15	104	5-15P
	208/230/60/1	0.6	0.08	0.72	0.125	4.1	20	5.4	6.4	15	197	6-15P
	265/60/1	0.67	0.08	0.7	0.125	3.35	18	4.7	5.6	15	240	7-20P
12	115/60/1	1.4	0.09	1.6	0.125	9.7	54	12.7	15.1	20	104	5-20P
	208/230/60/1	0.6	0.08	0.72	0.125	5.1	28	6.4	7.7	15	197	6-15P
	265/60/1	0.67	0.08	0.7	0.125	4.25	26	5.6	6.7	15	240	7-20P
15	208/230/60/1	0.6	0.08	0.72	0.125	6.4	35	7.7	9.3	15	197	6-15P
	265/60/1	0.67	0.08	0.7	0.125	5.4	32	6.8	8.1	15	240	7-20P
18	208/230/60/1	0.6	0.08	0.71	0.09	7.6	45	8.9	10.8	15	197	6-15P
	265/60/1	0.67	0.08	0.71	0.09	6.3	32	7.7	9.3	15	240	7-20P

NEMA Specifications Non-Locking/Receptacles									
VOLTAGE	125V			250V			265V		
	15(A)	20(A)	30(A)	15(A)	20(A)	30(A)	15(A)	20(A)	30(A)
PLUG									
RECEPTACLE	5-15 R	5-20 R	6-15 R	6-20 R	6-30 R	7-15 R	7-20 R	7-30 R	

An ECR International Brand
ENVIROMASTER INTERNATIONAL LLC
 5780 Success Dr., Rome, NY 13440
 Phone: 1-800-228-9364
 FAX: 1-800-232-9364
 Email: info@retroaire.com