

RETROAIRE

The Right Fit for Comfort

RC/RH22 DUAL MOTOR PACKAGED TERMINAL AIR CONDITIONER/HEAT PUMP

P/N# 240004376, Rev. 1.3 [02/05]

**Replacement for:
IceCap RSK & IslandAire EZ-RK Series**

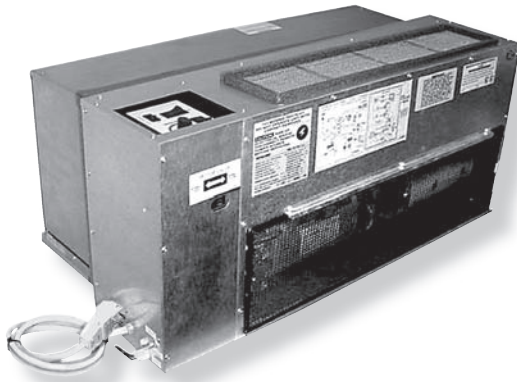

Cooling Only/Heat Pump

Nominal Capacities:

RC22; 9,000, 12,000, 15,000 & 18,000,
RH22; 9,000, 12,000, 15,000 Btuh

DESCRIPTION

The Retroaire RC/RH22 is designed for use in new construction or as a replacement for the IceCap RSK and IslandAire EZ-RK series packaged terminal air conditioner/heat pump.

The unit is available in cooling only as well as heat pump configurations and will fit into an existing wall sleeve. The RH22 heat pump provides heat when outside temperatures are as low as 40° F.

The RC/RH22 also offers an EER rating as high as 10.0. This can result in immediate energy savings over an older unit. The RC/RH22 features a two speed fan and an outdoor fan that conserves energy by not running in vent or electric heat modes.

Whisper-quiet operation adds to room ambiance and the permanent, washable filter makes service a snap. The 20 gauge, galvanized steel chassis construction ensures long unit life.

The Retroaire RC/RH22 is backed by EMI and ECR International and is tested and rated in accordance with ARI standards 310/380 and UL 484.

▲▼ **Capacities:** The RC/RH22 replacement chassis are available in nominal capacities of 9,000, 12,000, 15,000 and 18,000 Btuh.

▲▼ **Air Systems:**

- Fans - Forward curve type, mounted on motor shafts
- PSC motors with overheat protection
- Air surfaces insulated with 1/4" fiberglass
- Easy access permanent, washable air filter

▲▼ **Heat Exchanger** – Staggered seamless, rifled copper tubing w/aluminum fins tested to 460 psig. Tubing is mechanically expanded for secure bonding to fin shoulders.

▲▼ **Refrigeration Circuit:**

- High efficiency, rotary compressor w/standard 5 year warranty
- Automatic expansion valve metering for outdoor low outdoor ambient protection

▲▼ **Heat Pumps:**

- Heat pumps operate at outdoor temperatures as low as 35° F.
- Standard temperature actuated drain pan valve for heat cycle condensate disposal

CONTROLS AND COMPONENTS

▲▼ **Standard, Factory Installed:**

- Unit Mounted Operating Controls
 - Thermostat
 - Fan Speed Control
 - Heat/Cool Switch
 - Fan Cycle Switch
- Low Ambient Protection
- Normally Open/Closed Motor Valve-Switch (Hydronic Heat Only)

▲▼ **Accessories:**

- Custom Wall Sleeves, Louvers, and Cabinet Enclosure (Consult factory)
- Front Air Intake
- Electric Heat (2, 3, 4 or 5kw)
- Hydronic Heat (W/Original Cradle Design)
- Remote Thermostat
- Motorized Fresh Air Damper
- Disconnect Switch
- 115 Volt 09 & 12 (Only) or 265/277 Volt (All Models)

SPECIFICATIONS AND PERFORMANCE

RC/RH 22 SPECIFICATIONS AND PERFORMANCE DATA

NOTE: Due to EMI's ongoing product development programs, designs, specifications, and performance may change without notice.
For more information, please contact the factory.

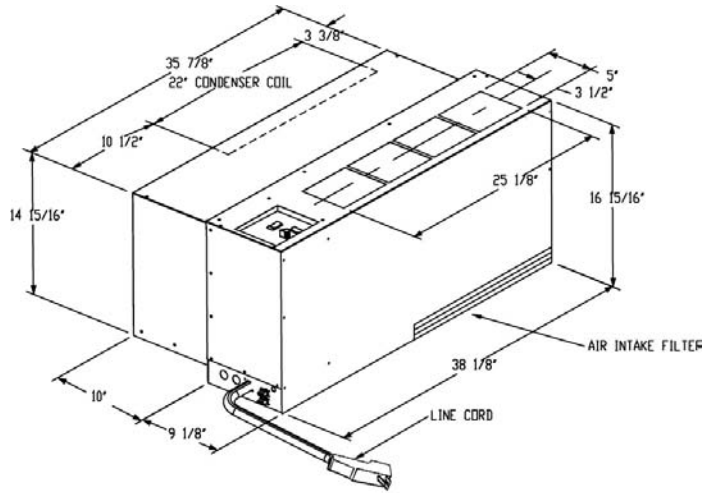

RC/RH 22 Electrical Specifications												
Model	Voltage/Hz/ Phase	Evap Motor		Cond Motor		Compressor		Total Amps	MCA	Max Fuse	Min Voltage	Line Cord
		FLA	Hp	FLA	Hp	RLA	LRA					
9	115/60/1	1.4	0.09	1.6	0.125	7.4	44	10.4	12.3	15	104	5-15P
	208/230/60/1	0.6	0.08	0.72	0.125	4.1	20	5.4	6.4	15	197	6-15P
	265/60/1	0.67	0.08	0.7	0.125	3.35	18	4.7	5.6	15	240	7-20P
12	115/60/1	1.4	0.09	1.6	0.125	9.7	54	12.7	15.1	20	104	5-20P
	208/230/60/1	0.6	0.08	0.72	0.125	5.1	28	6.4	7.7	15	197	6-15P
	265/60/1	0.67	0.08	0.7	0.125	4.25	26	5.6	6.7	15	240	7-20P
15	208/230/60/1	0.6	0.08	0.72	0.125	6.4	35	7.7	9.3	15	197	6-15P
	265/60/1	0.67	0.08	0.7	0.125	5.4	32	6.8	8.1	15	240	7-20P
18	208/230/60/1	0.6	0.08	0.71	0.09	7.6	45	8.9	10.8	15	197	6-15P
	265/60/1	0.67	0.08	0.71	0.09	6.3	32	7.7	9.3	15	240	7-20P

Note: Data will vary if alternate components (including compressor or motor) are used to meet production needs.
Consult factory for current electrical specifications.

RC/RH 22 Optional Electric Heat Specifications								
Heater No.	Voltage	Watts	Btuh	Amps	Total Heat Amps	MCA	Max Fuse	Line Cord
2	208	1636	5600	7.9	8.5	10.4	15	6-15P
	230	2000	6900	8.7	9.3	11.5	15	6-15P
	265	2655	9100	10.0	10.7	13.2	15	7-20P
3	208	2454	8400	11.8	12.4	15.3	20	6-20P
	230	3000	10300	13.0	13.6	16.9	20	6-20P
	265	3983	13600	15.0	15.7	19.5	20	7-20P
4	208	3271	11200	15.7	16.3	20.3	25	6-30P
	230	4000	13700	17.4	18.0	22.3	25	6-30P
	265	5310	18200	20.0	20.7	25.7	30	7-30P
5	208	4089	14000	19.7	20.3	25.2	30	6-30P
	230	5000	17100	21.7	22.3	27.8	30	6-30P

RC/RH 22 Performance Data						
Unit Size	Cooling Btuh	EERs	Heat Pump Btuh	COP	Evaporator CFM Hi/Lo	Fresh Air CFM
9	9,500	10	8500	2.8	440/340	40/35
12	11,900	10	11400	2.9	440/340	40/35
15	14,700	9.2	13800	2.8	500/440	40/35
18	16,900	9.1	N/A	N/A	500/440	40/35

RC 22 Hydronic Heat Performance* EMI (single row coil)			
GPM	EWT (°F)	Capacities Btuh	P.D.
3.0	180°F Hi	11,948	2.6
	180°F Lo	11,227	2.6
	140°F Hi	7,526	2.6
	140°F Lo	7,077	2.6

* Performance may vary depending on coil used.

NEMA Specifications Non-Locking/Receptacles									
VOLTAGE	125V			250V			265V		
	15(A)	20(A)		15(A)	20(A)	30(A)	15(A)	20(A)	30(A)
PLUG									
RECEPTACLE									

An **ECR International Brand**

ENVIROMASTER INTERNATIONAL LLC
5780 Success Dr., Rome, NY 13440