

RETROAIRE

The Right Fit for Comfort

RC/RH35 PACKAGED TERMINAL AIR CONDITIONER/HEAT PUMP

P/N# 240003258, Rev.1.1 [03/05]

Replacement For: Remington and Singer/
McQuay EA, ES, and RS Series

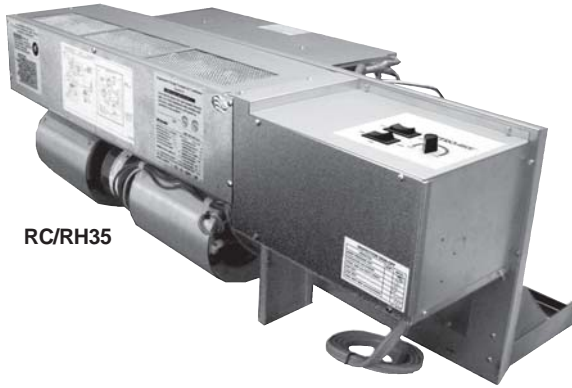

RC/RH35

STRAIGHT COOL/HEAT PUMP

Nominal Capacities: 9,000 - 12,000 -
15,000 - 18,000 Btuh

DESCRIPTION

The RetroAire RC/RH35 replacement chassis is a conditioner designed to allow owners of Remington and Singer/McQuay EA, ES, and RS Series and other packaged terminal units to upgrade room comfort while reducing operating costs through higher efficiency and enhanced reliability.

This unit is available as a cooling-only model or, for those who wish to upgrade to a heat pump, the RH 35 chassis will fit the existing wall sleeve. This heat pump replacement will reduce heating energy costs at outdoor temperatures as low as 30° F.

Energy efficiency ratings are as high as 10.0 E.E.R., which can mean rapid payback of your replacement investment through energy savings. The RetroAire™ RC/RH35 features two fan speeds. Its separate outdoor fan does not run in venting or heating modes, thereby saving energy.

Whisper-quiet operation improves the room ambiance and a washable, permanent filter makes service a snap. The 20 gauge, galvanized steel construction of the chassis ensures long service life.

All RetroAire products are backed by EMI and ECR International and are tested and rated in accordance with ARI Standards 310 & 380 and UL 484. A full service parts inventory is always available.

▲ **Capacities** – The RC/RH 35 Replacement Chassis are available in nominal capacities of 9,000, 12,000, 15,000, and 18,000 Btuh.

▲ **Air Systems:**

- Fans are forward-curved type, directly, mounted to the motor shafts.
- Motors are PSC type with overheat protection.
- Air-stream surfaces are insulated with ¼" fiberglass.
- Filter is permanent, washable, and accessible without tools.

▲ **High Efficiency Heat Exchanger** – Coil is seamless, rifled copper tubing, arranged in staggered configuration, with enhanced aluminum fins, tested to 460 psig. The tubes are mechanically expanded for secure bonding to fin shoulders.

▲ **Refrigeration Circuit:**

- High efficiency, rotary compressor with a five-year warranty standard.
- Automatic expansion valve refrigerant metering for low-ambient protection.

▲ **Heat Pumps:**

- Heat pump heating operates as low as 30° F outdoor temperature.
- Heat pumps include adjustable changeover temperature point and emergency heat position.
- A standard temperature actuated drain pan valve for heat cycle condensate disposal is included.

▲ **Accessories:**

- The RC/RH 35 units are designed to fit both the existing wall sleeve and cabinet of the old unit, but when either the sleeve or cabinet must be replaced because of rust or damage, RetroAire can supply custom replacements.
- Motorized fresh-air damper with positive-pressure seal and override switch.
- Continuous/cycling fan-control switch.
- Electric heat at 3, 4, or 5KW.

A Note On Wall Thickness

The distance from the condenser coil to the outdoor louver varies with sleeve depth. Each chassis includes a ½" air baffle to accommodate the most common condenser coil to outdoor louver requirements. In addition, we stock an optional condenser-side air baffle kit for chassis installation in deeper than standard wall sleeves.

SPECIFICATIONS AND PERFORMANCE

RC/RH35 DIMENSIONS SPECIFICATIONS

IMPORTANT: Due to RetroAire's on going development programs, designs and specifications may change without notice. Please consult factory for the latest information and submittal data before making any job site updates.

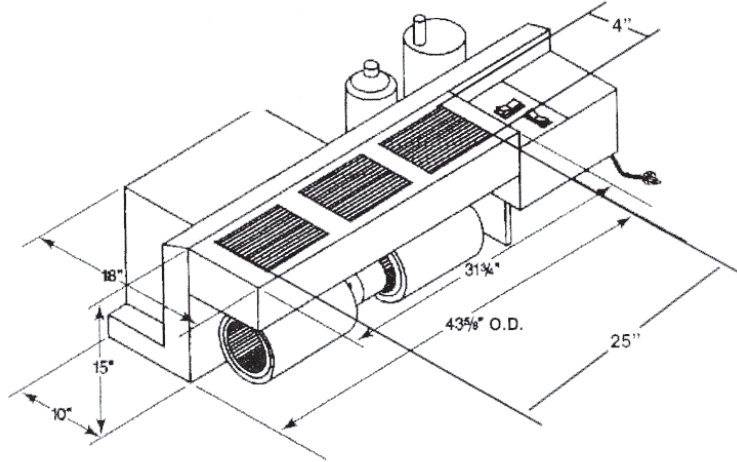

RC/RH35 Optional Electric Heat Specifications								
Heater No.	Voltage	Watts	Btuh	Amps	Total Heat Amps	MCA	Max Fuse	Line Cord
2	208	1,636	5,600	7.9	8.5	10.4	15	6-15P
	230	2,000	6,900	8.7	9.3	11.5	15	6-15P
	265	2,655	9,100	10	10.7	13.2	15	7-20P
3	208	2,454	8,400	11.8	12.4	15.3	20	6-20P
	230	3,000	10,300	13	13.6	16.9	20	6-20P
	265	3,983	13,600	15	15.7	19.5	20	7-20P
4	208	3,271	11,200	15.7	16.3	20.3	25	6-30P
	230	4,000	13,700	17.4	18	22.3	25	6-30P
	265	5,310	18,200	20	20.7	25.7	30	7-30P
5	208	4,089	14,000	19.7	20.3	25.2	30	6-30P
	230	5,000	17,100	21.7	22.3	27.8	30	6-30P

RC/RH35 Electrical Specifications												
Model Number	Voltage/Hz/Phase	Evap Motor		Cond Motor		Compressor		Total Amps	MCA	Max Fuse	Min Voltage	Line Cord
		FLA	HP	FLA	HP	RLA	LRA					
9	115/60/1	1.4	0.09	1.6	0.125	7.4	44	10.4	12.3	15	104	5-15P
	208/230/60/1	0.6	0.08	0.72	0.125	4.1	20	5.4	6.5	15	197	6-15P
	265/60/1	0.67	0.08	0.7	0.125	3.35	18	4.7	5.6	15	240	7-20P
12	115/60/1	1.4	0.09	1.6	0.125	9.7	54	12.7	15.1	20	104	5-20P
	208/230/60/1	0.6	0.08	0.72	0.125	5.1	28	6.4	7.7	15	197	6-15P
	265/60/1	0.67	0.08	0.7	0.125	4.25	26	5.6	6.7	15	240	7-20P
15	208/230/60/1	0.6	0.08	0.72	0.125	6.4	35	7.7	9.3	15	197	6-15P
	265/60/1	0.67	0.08	0.7	0.125	5.4	32	6.8	8.1	15	240	7-20P
18	208/230/60/1	0.6	0.08	0.71	0.09	7.6	45	8.9	10.8	15	197	6-15P
	265/60/1	0.67	0.08	0.71	0.09	6.3	32	7.7	9.3	15	240	7-20P

NEMA Specifications Non-Locking/Receptacles							
VOLTAGE	125V		250V			265V	
	15(A)	20(A)	15(A)	20(A)	30(A)	15(A)	20(A)
PLUG							
RECEPTACLE	5-15 R	5-20 R	6-15 R	6-20 R	6-30 R	7-15 R	7-20 R

RC/RH PERFORMANCE DATA						
MODEL	COOLING Btuh	EER	HEAT PUMP Btuh	COP	EVAP CFM HI/MED/LOW	FRESH AIR CFM
9	9,500	10	8,500	2.8	385/335	40/35
12	11,900	10	11,400	2.9	385/335	40/35
15	14,700	9.2	13,800	2.8	385/335	40/35
18	16,900	9.1	N/A	N/A	385/335	40/35



An **ECR** International Brand

ENVIROMASTER INTERNATIONAL LLC
 5780 Success Dr., Rome, NY 13440
 Phone: 1-800-228-9364
 FAX: 1-800-232-9364
 Email: info@retroaire.com

The Right Fit For Comfort

www.retroaire.com