

RETROAIRE

The Right Fit for Comfort

RC21 PACKAGED TERMINAL AIR CONDITIONER

P/N# 240003255, Rev. 1.4 [07/06]

Replacement For
**FRIEDRICH/CLIMATE MASTER
701 SERIES**

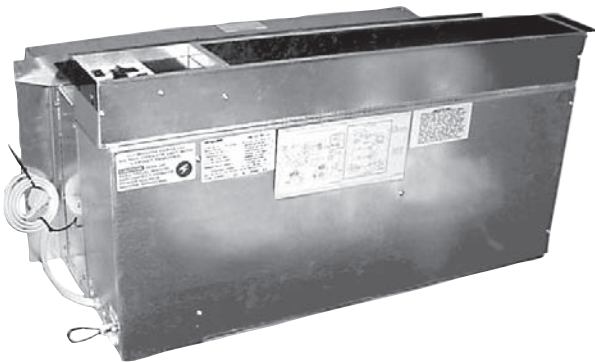

Straight Cool Only
Nominal Capacities: 9,000-
12,000 - 15,000 & 18,000 Btuh

PRODUCT DESCRIPTION

The RetroAire RC21 replacement chassis is an air conditioner designed to allow owners of Friedrich/Climate Master 701 Series packaged terminal units to upgrade room comfort while reducing operating costs through higher efficiency and enhanced reliability. This unit is available as a cooling-only model.

Energy efficiency ratings are as high as 10.0 E.E.R., which can mean rapid payback of your replacement investment through energy savings. The RetroAire RC21 features two fan speeds. Its separate outdoor fan does not run in venting or heating modes, thereby saving energy.

Whisper-quiet operation improves the room ambiance and a washable, permanent filter makes service a snap. The 20 gauge, galvanized steel construction of the chassis ensures long service life.

All RetroAire products are backed by EMI and by ECR International and are tested and rated in accordance with ARI Standards 310 & 380 and UL 484. A full service parts inventory is always available.

▲ **Capacities** – The RC21 Replacement Chassis is available in nominal capacities of 9,000, 12,000, 15,000 and 18,000 Btuh.

▲ Air Systems

- Fans are forward-curved type, directly mounted to the motor shafts.
- Motors are PSC type with overheat protection.
- Airstream surfaces are insulated with ¼" fiberglass.
- Filter is permanent, washable and accessible without tools.

▲ **High Efficiency Heat Exchanger** – Coil is seamless, rifled copper tubing, arranged in staggered configuration, with enhanced aluminum fins, tested to 460 psig. The tubes are mechanically expanded for secure bonding to fin shoulders.

▲ Refrigeration Circuit:

- High-efficiency, rotary compressor with a five year warranty standard.
- *Automatic expansion-valve refrigerant metering for low-ambient protection, allows cooling down to 35° F.*

▲ Accessories:

- *Motorized fresh-air damper with positive-pressure seal and override switch*
- *Continuous/cycling fan-control switch*
- *3, 4 or 5KW electric heat*
- *Hydronic Heat*

Important: *The RC21 is designed to fit both the existing wall sleeve and cabinet of the old unit. When either the sleeve or the cabinet must be replaced because of rust or damage, Retroaire offers to supply custom replacements.*

A Note On Wall Thickness

The distance from the condenser coil to the outdoor louver varies with sleeve depth. Each chassis includes a 13¼ 4" air baffle to accommodate the most common condenser coil to outdoor louver requirements. In addition, we stock an optional condenser-side air baffle kit for chassis installation in deeper than standard wall sleeves. The kit's two-piece sliding design.

RC21 SPECIFICATIONS

Note: *Data will vary if alternate components (including compressor or motor) are used to meet production needs. Consult factory for current electrical specifications.

DIMENSIONS			
Unit Size	Dim. A	Dim. B	Dim. C
09-12	20 1/4"	9 7/8"	10 3/8"
15-18	25 1/4"	10 1/8"	15 3/8"

RC21 PERFORMANCE DATA*				
Unit Size	Cooling Btuh	EERs	Evaporator CFM Hi/Lo	Fresh Air CFM
09	9,500	10.0	440/340	40/35
12	11,900	10.0	440/340	40/35
15	14,700	9.2	500/440	40/35
18	16,900	9.1	500/440	40/35

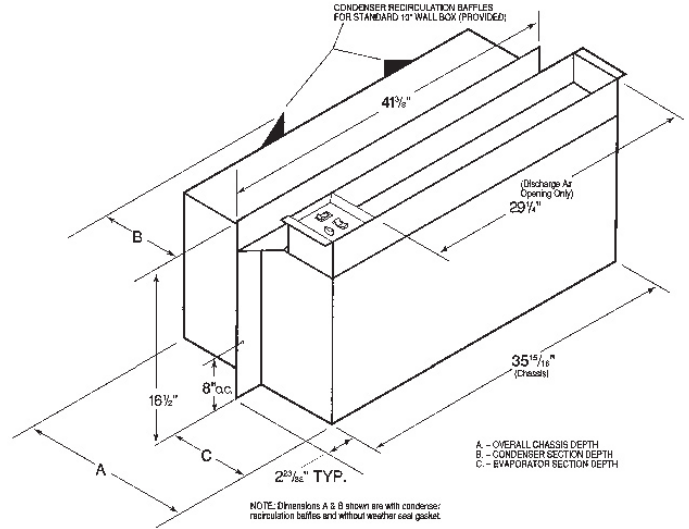

RC21 ELECTRICAL SPECIFICATIONS*												
Model Number	Voltage/hz/ph	Evap Motor		Cond Motor		Compressor		Total Amps	MCA	Max Fuse	Min Voltage	Line Cord
		FLA	Hp	FLA	Hp	RLA	LRA					
09	115/60/1	1.4	0.09	1.6	0.125	7.4	44	10.4	12.3	15	104	5-15P
	208/230/60/1	0.6	0.08	0.72	0.125	4.1	20	5.4	6.4	15	197	6-15P
	265/60/1	0.67	0.08	0.7	0.125	3.35	18	4.7	5.6	15	240	7-20P
12	115/60/1	1.4	0.09	1.6	0.125	9.7	54	12.7	15.1	20	104	5-20P
	208/230/60/1	0.6	0.08	0.72	0.125	5.1	28	6.4	7.7	15	197	6-15P
	265/60/1	0.67	0.08	0.7	0.125	4.25	26	5.6	6.7	15	240	7-20P
15	208/230/60/1	0.6	0.08	0.72	0.125	6.4	35	7.7	9.3	15	197	6-15P
	265/60/1	0.67	0.08	0.7	0.125	5.4	32	6.8	8.1	15	240	7-20P
18	208/230/60/1	0.6	0.08	0.71	0.09	7.6	45	8.9	10.8	15	197	6-15P
	265/60/1	0.67	0.08	0.71	0.09	6.3	32	7.7	9.3	15	240	7-20P

RC21 OPTIONAL ELECTRIC HEAT SPECIFICATIONS*								
Heater No	Voltage	Watts	Btuh	Amps	Total Heat Amps	MCA	Max Fuse	Line Cord
2	208	1636	5600	7.9	8.5	10.4	15	6-15P
	230	2000	6900	8.7	9.3	11.5	15	6-15P
	265	2655	9100	10.0	10.7	13.2	15	7-20P
3	208	2454	8400	11.8	12.4	15.3	20	6-20P
	230	3000	10300	13.0	13.6	16.9	20	6-20P
	265	3983	13600	15.0	15.7	19.5	20	7-20P
4	208	3271	11200	15.7	16.3	20.3	25	6-30P
	230	4000	13700	17.4	18.0	22.3	25	6-30P
	265	5310	18200	20.0	20.7	25.7	30	7-30P
5	208	4089	14000	19.7	20.3	25.2	30	6-30P
	230	5000	17100	21.7	22.3	27.8	30	6-30P

RC21 HYDRONIC HEAT * Performance 104-101 (Single Row Coil)			
GPM	EWT (°F)	Capacities Btuh	P.D.
3.0	180°F Hi	16,400	4.4
	180°F Lo	15,400	4.4
	140°F Hi	10,300	4.6
	140°F Lo	9,700	4.6

NEMA Specifications Non-Locking/Receptacles								
VOLTAGE	125V			250V			265V	
	15(A)	20(A)	30(A)	15(A)	20(A)	30(A)	15(A)	20(A)
PLUG								
RECEPTACLE	5-15 R	5-20 R	6-15 R	6-20 R	6-30 R	7-15 R	7-20 R	7-30 R

An **ECR International Brand**
ENVIROMASTER INTERNATIONAL LLC
 5780 Success Drive, Rome, NY 13440