

**VPAC/VPHP 30-36  
SINGLE PACKAGE VERTICAL AIR CONDITIONER  
(SPVAC) AND HEAT PUMP (SPVHP)**

**Straight Cool/Heat Pump**  
Nominal Capacities:  
30,000-36,000 Btuh

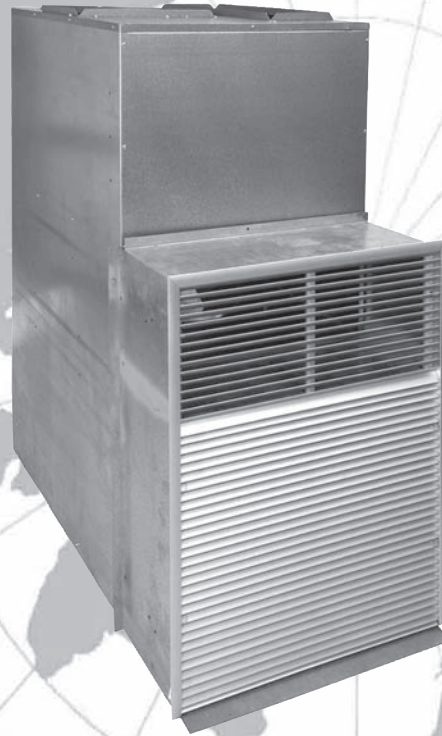

VPAC/VPHP

Enviromaster International LLC  
5780 Success Dr.  
Rome, NY 13440  
[www.enviromaster.com](http://www.enviromaster.com)

An **ECR** International Brand  
An ISO 9001-2000 Certified Company



P/N# 240004554, Rev. 1.1 [02/05]

# VPAC/VPHP 30-36 SINGLE PACKAGE VERTICAL AIR CONDITIONER (SPVAC) AND HEAT PUMP (SPVHP)

## INSTALLATION, OPERATION, AND MAINTENANCE MANUAL

P/N 240004554 Rev. 1.1 [02/05]

**Shipping Damage MUST be Reported to the Carrier IMMEDIATELY!!!  
Examine the exterior. Remove cover and examine compressor and piping for signs of damage.**

This manual is intended as an aid to qualified service personnel for proper installation, operation, and maintenance of the VPAC/VPHP 30-36 Packaged Terminal Air Conditioner (PTAC). Read these instructions thoroughly and carefully before attempting installation or operation. Failure to follow these instructions may result in improper installation, operation, service, or maintenance, possibly resulting in fire, electrical shock, property damage, personal injury, or death.

### TO THE INSTALLER

- (1) Retain this manual and warranty for future reference.
- (2) Before leaving the premises, review this manual to be sure the unit has been installed correctly and run the unit for one complete cycle to make sure it functions properly.

To obtain technical service or warranty assistance during or after the installation of this unit, contact your local representative. Visit our website [www.retroaire.com](http://www.retroaire.com) for a local representative listing. For further assistance call 1-800-228-9364.

When calling for assistance, please have the following information ready:

- Model Number \_\_\_\_\_
- Serial Number \_\_\_\_\_
- Date of installation \_\_\_\_\_

### SAFETY INSTRUCTIONS

- ▲ Read all instructions before using the VPAC/VPHP PTAC. Install or locate this unit only in accordance with these instructions. Use this unit only for its intended use as described in this manual.
- ▲ Check the rating plate on the VPAC/VPHP PTAC before installation to make certain the voltage shown is the same as the electric supply to the unit.
- ▲ The VPAC/VPHP PTAC must be connected only to a properly grounded electrical supply. Do not fail to properly ground this unit.
- ▲ Turn off the electrical supply before servicing the VPAC/VPHP PTAC.
- ▲ Do not use the VPAC/VPHP PTAC if it has damaged wiring, is not working properly, or has been damaged or dropped.

*[Save These Instructions]*



**Recognize this symbol as an indication  
of important safety information**



## TABLE OF CONTENTS

To the Installer and Safety Instructions.....	2
Warnings and Installer Responsibilities.....	3
Product Description .....	4
Controls, Components & Options .....	4
Application Limitations .....	4
Air System, Electrical Wiring, .....	5
General Installation, Condensate Drain.....	5-6
Indoor Motor Speed Tap Selection .....	7
Return Air Access Panel.....	7
Final Inspection and Start-up .....	7
Sequence of Operation .....	8
Maintenance .....	9
Troubleshooting .....	10
Specifications and Dimensions .....	10-11

## INSTALLER RESPONSIBILITIES

This manual has been prepared to acquaint you with the installation, operation and maintenance of this VPAC/VPHP 30-36 PTAC and to provide important safety information in these areas.

We urge you to read all of the instructions thoroughly before attempting the installation or operation of this unit. This manual should be kept for future reference.

The manufacturer of this unit will not be liable for any damages caused by failure to comply with the installation and operating instructions outlined in this manual.

A rating plate identifying this VPAC/VPHP PTAC can be found on the unit. When referring to your unit, always have the information listed on the rating plate readily available.

## MODIFICATION AND TAMPERING



**Tampering with the VPAC/VPHP is dangerous and may result in serious injury or death. Tampering voids all warranties. Do not attempt to modify or change this unit in any way.**



**Completely read all instructions prior to assembling, installing, operating, or repairing this product. Inspect all parts for damage prior to installation and start-up. The VPAC/VPHP PTAC must be installed ONLY by qualified installation personnel.**



**The RetroAire PTAC must:**

- ▲▼ **Be connected to a properly grounded electrical supply with the proper voltage as stated on the rating plate.**
- ▲▼ **Have proper over current protection (i.e. time- delay fuse/HACR-Breaker) as listed on the Rating Plate.**

**Failure to follow these instructions can result in a fire, explosion, or electrical shock causing property damage, personal injury, or death.**

# VPAC/VPHP 30-36 AIR CONDITIONER (SPVAC) AND HEAT PUMP (SPVHP)

## PRODUCT DESCRIPTION

The VPAC/VPHP 30-36 single package vertical air conditioner (SPVAC) and heat pump (SPVHP) creates new options in layout and space utilization. The VPAC/VPHP 30-36 offers low cost operation and quiet, comfortable air distribution, especially when used in multi-room suites, apartments, healthcare facilities, and homes.

Framed into a concealed closet enclosure for low operating sound levels, the VPAC/VPHP 30-36's vertical discharge vent allows ducting to the top of the room(s) for superior air circulation and distribution. Multiple air supply grilles can distribute air when used with a soffit and intake grilles can be located on the sides of the enclosure.

The VPAC/VPHP 30-36 can be applied in a ducted return air application or can remain non-ducted as delivered. If ducted, the closet enclosure does not require minimum clearances other than what is recommended for adequate service access. If non-ducted, minimum clearance options must be adhered to as dictated for optimal performance and sound. See note on minimum clearance dimensions in the illustration titled "Exploded View Of Typical Installation" on page 2 of this document. (Figure 1)

The VPAC/VPHP 30-36 offers an economic benefit when used in a multi-room suite by supplying conditioned air to more than one room without the need to install another PTAC/PTHP. This is also a design advantage since the second room does not need an exterior wall for a second unit.

The VPHP 30-36 heat pump is intended to be a limited range heat pump, which means utilizing a supplemented heat option is recommended since heat pump operation will cease at approximately 40°F outdoor temperature. Consult factory for availability of a full range defrosting heat pump version.

Each system is supplied with a ready-to-install wall sleeve and outdoor louver. The cabinet is constructed with 20 gauge galvanized steel with a G-90U corrosion resistant rating and the insulated top discharge evaporator compartment provides quiet ducted, conditioned air delivery to other room location(s).

The VPAC/VPHP 30-36 is backed by EMI and ECR International and is tested and rated in accordance with ARI standard 390 and UL-1995. Due to ongoing product development, product designs and specifications may change without notice. Please contact the factory for more information.

## STANDARD CONTROLS AND COMPONENTS

- Cooling or heat pump chassis w/high efficiency scroll or reciprocating type compressor
- Custom wall sleeve
- Anodized aluminum outdoor louver for field installation (optional colors available)
- Front mounted control box
- Manual fresh air damper
- Microprocessor control board
  - Universal control board: can be used in straight cool electric, hydronic heat, or cooling/heat pump applications.
  - Fan purge: fan remains on for 60 seconds after heat/cool call is dropped ("auto" mode only)
  - Anti-short cycle compressor protection
  - Random start timer: prevents multiple units from simultaneous start-ups (straight cool only)
  - Freeze protection: prevents evaporator freeze ups
  - Low ambient lockout: prevents compressor operation in cold outdoor temperatures.
  - Test operation: all timers are eliminated to allow ease of testing after installation (straight cool only)
  - Compatible with fossil fuel, electric heat, mercury or electronic thermostats
  - Refrigerant hot gas bypass for operation in low outdoor ambient conditions (cooling cycle only)

## OPTIONAL CONTROLS AND COMPONENTS

- Supplemental electric heat
- 265/277V (contact factory for availability)
- Painted condenser louver
- Remote wall thermostat
- Return air access panel (w/disposable return air filters)

## APPLICATION LIMITATIONS

The VPAC/VPHP 30-36 should be installed in accordance with all national and local safety codes.

APPLICATION LIMITATIONS						
Outdoor Ambient Air Temp. °F			Indoor Ambient Air Temp. °F			
Minimum DB	Maximum DB		Minimum		Maximum	
	Cool	Heat	DB/WB	DB	DB/WB	DB
Cool	Cool	Heat	Cool	Heat	Cool	Heat
67	115	75	67/57	50	90/72	80

## VPAC/VPH 30-36 AIR CONDITIONER (SPVAC) AND HEAT PUMP (SPVHP)

Minimum and maximum operation conditions must be observed to assure maximum system performance with minimum service required. Refer to table below for application limitations of the VPAC/VPH 30-36.

### CAUTION

Avoid possibility of electric shock and personal injury. Disconnect all power before removing chassis or performing any cleaning, servicing, or maintenance.

### CONDENSATE REMOVAL

The VPAC/VPH 30-36 requires an internal drain system due to its unique draw-thru condenser design. Condenser side drain stub(s) are integral to the chassis and are very easy to connect a drain hose to.

### AIR SYSTEMS

Motors are thermally protected PSC type. Air stream surfaces are insulated with 1/4 inch fiberglass or 1/8 inch volara. The evaporator fan is a forward curved type directly mounted to the motor shaft. The condenser propeller utilizes a draw-thru design for improved efficiency.

### ELECTRICAL WIRING

#### WARNING

Before accessing the control compartment, disconnect power to the unit. Failure to do so could result in serious injury or electrical shock.

All field wiring must be done in accordance to NEC and local codes. Check the unit rating plate for circuit ampacity and breaker(s) or fuse size(s). Use only HACR type breakers or time delay fuses. Select the proper wire for the ampacity rating. Some units require more than one power supply. Check the nameplate and wiring diagram for further instructions.

**IMPORTANT:** The unit is wired for 230V primary voltage from the factory. The transformer must be rewired by the installer if the jobsite voltage is 208V.

Each vertical unit is equipped for a 24V wall thermostat connection.

### GENERAL INSTALLATION

Enviromaster International recommends installing the VPAC/VPH 30-36 before any carpentry work is started for the enclosure. It is very important for proper air flow and sound levels that a minimum clearance of 6" between the enclosure and the chassis be maintained. It is also very important that the rough opening in the wall for the wall sleeve and louver be the correct dimension and in the exact position necessary for installation. (Figure 1)

Figure 1

#### Exploded View Of Typical Installation

For designed performance, sound levels, and service, maintain a minimum of 6" on both sides and front for non-ducted return air applications only.

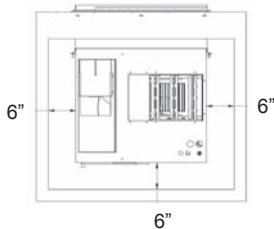

Ducted return air applications only require minimal spacing for service requirements.

Consult ECR Engineering if these minimums can not be met. Depending on the application and return air introduction, some reconfiguration is likely to be accommodated.

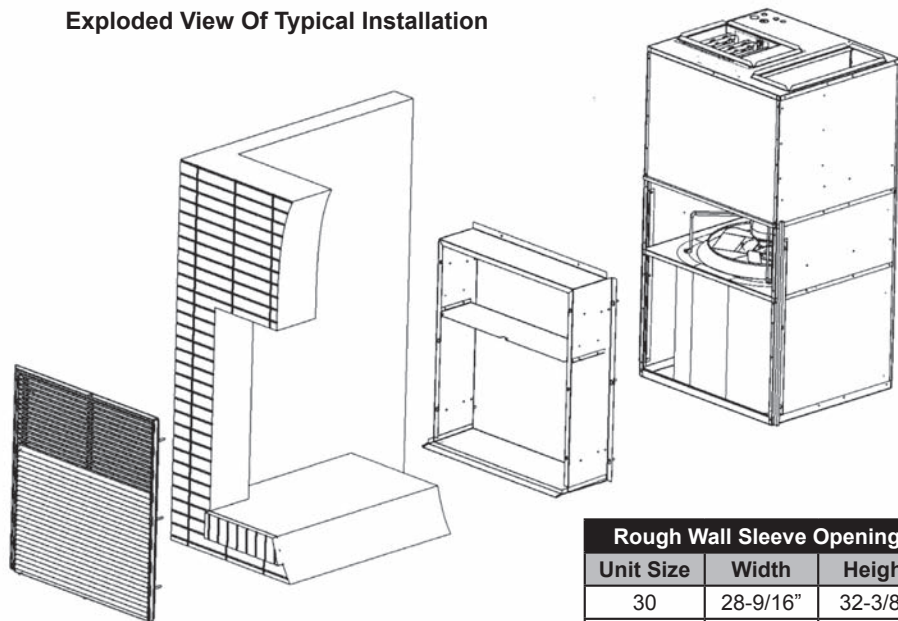

Rough Wall Sleeve Opening		
Unit Size	Width	Height
30	28-9/16"	32-3/8"
36	28-9/16"	36-1/4"

## VPAC/PHP 30-36 AIR CONDITIONER (SPVAC) AND HEAT PUMP (SPVHP)

**Figure 2**

### Determining Wall Sleeve Depth

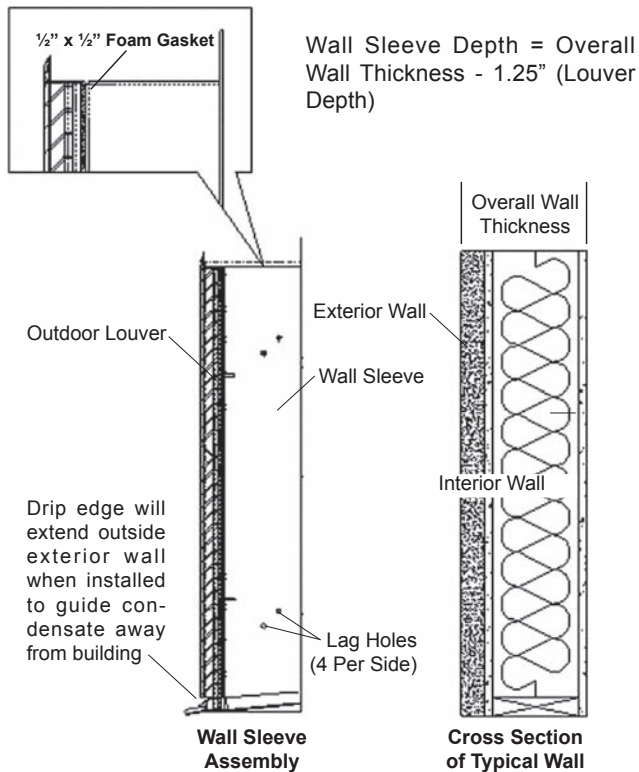

The platform height should be the same level as the bottom of the wall opening. Because wall sleeve depths can vary depending on overall wall thickness, it is critical that wall thickness be determined before ordering the wall sleeve. **(Figure 2)** Consult factory for available wall sleeve sizes.

1. Install 1/2" x 1/2" or 1" x 1" foam tape (supplied) to the unit condenser top and sides to seal against the wall sleeve. **(Figure 3)**

**Figure 3**

### Insulation & Weather Angles

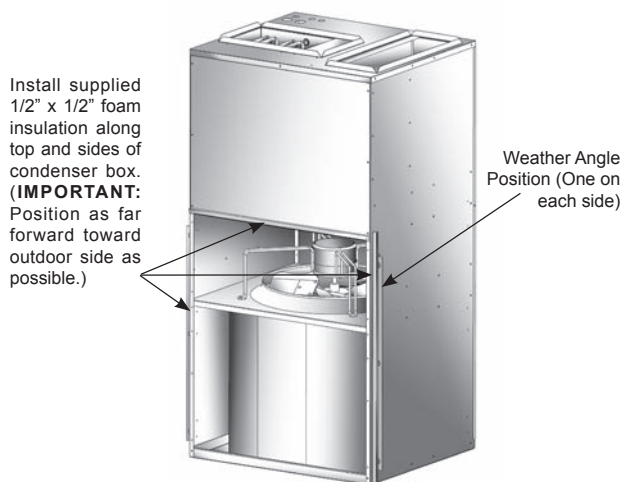

2. Attach the weather angles to the chassis using the screws provided.
3. Slide chassis into wall sleeve, assuring that wall sleeve studs on the wall sleeve flanges align with the holes in the weather angles.
4. Attach left and right weather angles to wall sleeve using the two 1/4-20 nuts provided.
5. Install plenum and duct work.
6. Plug in the supplied low voltage harness and run it to the wall thermostat as shown in the unit's wire diagram.

## CONDENSATE DRAIN

The VPAC/PHP 30-36 is equipped with a 3/4" condenser side drain stub in the front of the base pan. **Because of the unit's unique draw-thru condenser design, this drain stub must be connected to an internal condensate removal system. (Figure 4)**

**Figure 4**

**Drain stub must be connected to an internal condensate removal system.**

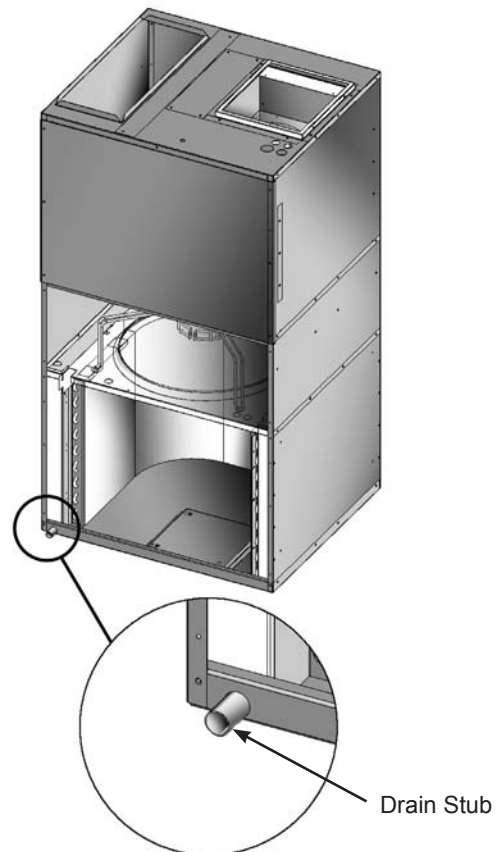

# VPAC/PHP 30-36 AIR CONDITIONER (SPVAC) AND HEAT PUMP (SPVHP)

## INDOOR MOTOR SPEED TAP SELECTION



**WARNING**

Before accessing the control compartment, disconnect power to the unit. Failure to do so could result in serious injury or electrical shock.

For information on indoor motor speed tap selection, please refer to the “VPAC/PHP 30-36 Indoor Motor Speed Tap Selection Chart” (**Figure 5**) and/or the label attached to the chassis of the unit.

**Figure 5**

VPAC/PHP 30-36 Indoor Motor Speed Tap Selection Chart				
Unit Size	ESP	230V	208V	197V
30	0.1	Blu	Blu	Blu
	0.2			Blk
	0.3			
36	0.1	Blk	Blk	Blk
	0.2			
	0.3			

Tap Key: Blu = Med, Blk = High

The motor comes factory wired for the corresponding units as described in the 230V column. Please make speed tap changes as required by job site voltage and/or external static pressure (e.s.p.) Speed tap changes may need to be made from factory settings and Enviromaster International will not be liable for any system problems that could arise if motor speed is not changed to match application.

## RETURN AIR ACCESS PANEL (WITH FILTER)

Return air access panels are unit capacity specific. Be sure to specify unit capacity when placing an order.

It is necessary to work closely with the other trades to locate the opening for the return air access panel. The return air access panel must be installed with enough room available to remove the unit if necessary. The frame is installed with screws through the lag holes into the frame studs and should be level and plum. (**Figure 6**) The return air access panel is set onto the frame and held in place with six screws.

**Figure 6**

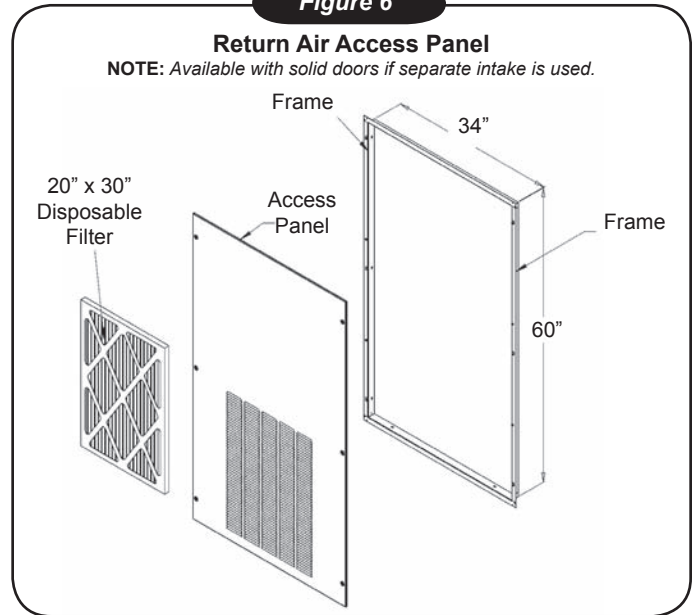

## FINAL INSPECTION AND START UP



**WARNING**

Moving parts can cause injury so exercise caution when testing the unit.

1. Hard wire line voltage power to unit. Refer to unit rating plate for proper voltage and amperage/fuse size.

**NOTE:** Some units may require two power supplies (check nameplate and wiring diagram for further instructions.)

2. Connect low voltage wiring from thermostat to unit.

**IMPORTANT:** The outdoor air sheet metal splitter baffle must be in the proper position to prevent recirculation.

3. Turn power on and check for proper operation.

**HEATING:** Set the wall thermostat to heat mode. Set the thermostat above the room setting. Allow some time for heat to come from the discharge grilles. Do not operate unit when the panels are removed.

**COOLING:** Set the wall thermostat to cool mode. Set the thermostat below the room temperature setting and allow time for cool air to come from the discharge grilles. The thermostat can be set at the most desired setting with the selector switch in the heat or cool position.

4. Make sure that there is nothing to interfere with the room discharge air or the return air.



**WARNING**

Do not operate unit without filter in place or use as a temporary heating/cooling source during construction.

## VPAC/VPHP 30-36 AIR CONDITIONER (SPVAC) AND HEAT PUMP (SPVHP)

### MANUAL FRESH AIR DAMPER

The fresh air manual damper allows the user to move fresh air into the space to be conditioned. The damper handle is located behind the evaporator coil. To access, slide access door on service panel and slide fresh air door to desired position.

### SEQUENCE OF OPERATION

#### CHOOSING A THERMOSTAT

Enviromaster International offers a thermostat that is compatible with the VPAC/VPHP 30-36. This is a single stage cool/heat, mercury bulb thermostat that can be used in all Retroaire cooling, heating or heat pump applications. The thermostat has an adjustable set-point range of between 55°F and 95°F. There are two independent, adjustable stops that can limit the heating or cooling range of the thermostat. A non-mercury, electronic thermostat is available if needed. Please contact the factory for more information.

#### SELECTING A COMPATIBLE THERMOSTAT

When selecting a thermostat other than those offered by Enviromaster International, it is important to choose a single stage heat/cool, 24V thermostat.

#### COOLING ONLY WITH ELECTRIC OR HYDRONIC HEAT (VPAC ONLY)

Select a thermostat that is compatible with a cooling - electric heat system. The thermostat should have "R", "Y", "W" and "G" terminals.

#### HEAT PUMP WITH ELECTRIC HEAT (VPHP ONLY)

Select a thermostat that is compatible with a cooling - single stage heat - heat pump system. The thermostat should have "R", "Y", "O" and "G" terminals. Retroaire™ units are single stage heating only. The electric heat and heat pump will not operate simultaneously.

#### FAN OPERATION

Some thermostats are equipped with an auto/on fan switch. When this switch is placed in the on position the indoor fan will run continuous. When the switch is in the auto position the indoor fan will cycle with the call for heating or cooling.

### FAN PURGE (AUTO MODE ONLY)

After the room thermostat has been satisfied, the purge feature allows the indoor fan to remain on for an additional 60 seconds. This increases efficiency by pulling the remaining energy from the unit.

### COOLING OPERATION

After connecting the thermostat to the unit place the system switch in cool mode. Adjust the set-point temperature below the room temperature. The compressor and fan motors will start and cooling will begin. Place the set-point temperature above the room temperature. The compressor and condenser fan will stop and the indoor fan will remain on for an additional sixty seconds.

**IMPORTANT:** The start of the compressor will not take place until the anti-short/random start time period has elapsed.

### ELECTRIC HEAT OPERATION

Place the thermostat system switch in heat mode. Adjust the set-point temperature above the room temperature. The electric heat will energize along with the indoor fan motor. Heating will continue so long as the set-point remains above room temperature. Next place the set-point temperature below room temperature. The electric heater will switch off and the indoor fan will remain on for an additional 60 seconds.

### HEAT PUMP COOLING OPERATION (VPHP ONLY)

Cooling operation in a heat pump unit is described in "Cooling Operation" above. The unit is equipped with a reversing valve that is energized for cooling and de-energized in heating mode.

### HEAT PUMP HEATING OPERATION (VPHP ONLY)

Heat pump units are "Limited Range" equipped with back-up electric resistance heat. Limited range heat pumps are designed to operate when outdoor temperatures are between 75°F and 40°F and with a maximum indoor temperature of 80°F. When the outdoor temperature falls below approximately 40°F the unit will switch from heat pump to electric resistance heat. Electric heat will then remain as the heat source until the outdoor temperatures rise above 50°F. The VPHP 30-36 is a single-stage heating unit. The electric heat and heat pump will not operate simultaneously.



## VPAC/VPH 30-36 AIR CONDITIONER (SPVAC) AND HEAT PUMP (SPVHP)

To operate the unit in heating mode, it must first be connected to an appropriate heat pump thermostat. (See "Choosing A Thermostat"). Select heat on the thermostat system switch. Then, adjust the set-point temperature above the room temperature. The compressor and fan motors will start and heating will begin. If the outdoor temperature is below approximately 40°F the heat pump system will not operate. Electric heat will then take over the heating demand. Heating will continue so long as the set-point temperature remains above the room temperature. Place the set-point temperature below the room temperature. The heating mode will cease and the indoor fan will remain on for an additional sixty seconds.

**IMPORTANT:** The start of the compressor will not take place until the anti-short/random start time period has elapsed.

### EMERGENCY HEAT (VPH ONLY)



Before accessing the control compartment, disconnect power to the unit. Failure to do so could result in serious injury or electrical shock.

Should the heat pump system fail, it is possible to force the control board into electric heat mode. This is a temporary solution until the heat pump system can be repaired. Locate the circuit board in the control section of the unit. Locate the terminals where the outdoor sensor connects to the circuit board. Using a small needle nose type pliers, disconnect one side of the sensor from the circuit board. This will appear to the circuit board as an outdoor coil freeze condition, thereby energizing the electric resistance heater on the call for heat.

### ANTI-SHORT CYCLE TIMER RANDOM START

This feature will prevent compressor short cycling and also prevent multiple units in a single facility from simultaneously starting following a power outage. This delay on break feature ensures that the compressor remains off between cycles until the three-minute time delay period has elapsed, allowing system pressures to equalize before restarting.

The random start feature, initiated after a power failure, will add a random time delay (between 5-120 seconds) to the three-minute anti short cycle time following a power outage. This will stagger the starting of multiple units in a single facility allowing a building to slowly go back on line when power is restored.

### INDOOR COIL FREEZE PROTECTION

This feature will prevent the indoor coil from freeze up in the cooling mode. Indoor coil freeze up can occur due to a dirty air filter, low refrigerant charge or low room or outdoor temperatures. This in turn can cause compressor damage. Should a freeze condition be detected, the compressor and condenser fan will be switched off for a minimum of three minutes and until the freeze condition is satisfied. During this time the indoor fan will continue to run to aid in the defrost process.

### MAINTENANCE



Before accessing the control compartment, disconnect power to the unit. Failure to do so could result in serious injury or electrical shock.

The VPAC/VPH 30-36 is designed and constructed for reliability and long life minimal maintenance. Scheduled maintenance inspections should be performed 4 times a year. At the beginning of the cooling season, a complete mechanical cooling check should be performed and periodic minor inspections may be necessary during the cooling season to adjust for variations in climate. At the beginning of the heating season, a complete mechanical heating check should be performed and, again, periodic minor inspections may be necessary to adjust for climatic changes.



It is illegal to discharge refrigerant into the atmosphere. Use proper reclaiming methods and equipment when repairing this unit. Service should be performed by a qualified service agency.

1. Disconnect power to the unit.
2. Remove the access panel and do a visual check of the equipment. Look for obvious changes in the unit such as damaged coils or evidence of extended wear on any moving parts. Check for unusual odors or leaks (ex: burnt motor windings, water, or refrigerant) and make sure the base pan is clean.
3. Regular cleaning of the filter is required. Allowing dust to collect on the filter will cause the unit to lose efficiency and eventually malfunction. Check filter once a month.

## VPAC/VPH 30-36 AIR CONDITIONER (SPVAC) AND HEAT PUMP (SPVHP)

4. Inspect all electrical connections for frayed wires and poor connections. Terminal ends that are loose will eventually fail, causing a loss of performance or worse.

5. Check fan motors and blower assemblies. Some units may require a drop of light oil to motors and/or bearing assemblies. Check setscrews and motor mounting hardware, making sure these are tight.

6. Centrifugal fan blades and blower cage assemblies must be clean to operate efficiently. Brush and/or vacuum as necessary.

7. Inspect both indoor and outdoor coils. Use a fin comb to straighten out any damaged fins. These coils must be clean for proper operation.

**IMPORTANT:** Do not use a solvent-based cleaner for this as some solvents produce a noxious odor when you start the fan or electric heat.

8. Look for oil leaks or stains on or around the coil and refrigerant lines. The presence of oil here indicates a potentially serious problem (such as a refrigerant leak).

9. Inspect and clean the drain pan and drain line(s). A good idea here is to use an anti-fungicide tablet to keep the condensate system free from bacterial contaminants.

10. Check seal around the unit.

**IMPORTANT:** Air leaks may make the conditioned area uncomfortably drafty or produce noises. Visually inspect the foam gasket between the wall and the unit, especially taking note of the separation between the air inlet for the condenser and the condenser coil discharge. **These two areas must be sealed off from each other.** If you experience poor cooling operation or erratic operation, check for air recirculation at the condenser coil.

11. Replace panel and reconnect the electrical power.

### TROUBLESHOOTING

#### NO HEAT OR COOLING

Check to see if the unit has power and if the thermostat is satisfied. If the thermostat is not satisfied, call your installing contractor or service contractor.

## SPECIFICATIONS AND PERFORMANCE

**IMPORTANT:** Due to ongoing product development, designs, specifications, and performance are subject to change without notice. Please consult the factory for further information.

VPAC/VPH 30-36 Performance Data									
Model	Cooling Btu	Sensible Heat	EER	SEER	Heat Pump	COP	External Static		
							.10	.20	.30
VPAC30	30,000	0.68	9.2	9.7	N/A	N/A	1,050	990	930
VPAC36	36,000	0.70	9.8	10.0	N/A	N/A	1,350	1,290	1,210
VPH30	29,800	0.73	8.7	9.7	27,600	2.4	1,050	990	930
VPH36	35,600	0.74	9.0	9.7	33,500	2.7	1,350	1,290	1,210

VPAC 30-36 COOLING ONLY ELECTRICAL SPECIFICATIONS											
Model Number	VOLTS/HZ/PH	Condenser Fan		Compressor		Evap Fan		Total Amps	Min Voltage	M.C.A.	Max HACR Breaker
		Amps	HP	RLA	LRA	Amps	PH				
30	208/230/60/1	1.7	0.25	14.0	73	3	0.5	18.7	197	22.3	35
36	208/230/60/1	1.7	0.25	16.3	88	3	0.5	21.0	197	25.1	40

VPAC 30-36 HEAT PUMP ELECTRICAL SPECIFICATIONS											
Model Number	VOLTS/HZ/PH	Condenser Fan		Compressor		Evap Fan		Total Amps	Min Voltage	M.C.A.	Max HACR Breaker
		Amps	HP	RLA	LRA	Amps	PH				
30	208/230/60/1	1.7	0.25	14.0	73	3	0.5	18.7	197	22.3	35
36	208/230/60/1	1.7	0.25	16.3	100	3	0.5	21.0	197	25.1	40

## SPECIFICATIONS AND PERFORMANCE

**IMPORTANT:** Due to ongoing product development, designs, specifications, and performance are subject to change without notice. Please consult the factory for further information.

		Model	
		30	36
Dimension in Inches	A	52"	56"
	B	28"	28"
	C	24 1/2"	28"
	D	20"	20"
	E	2 1/4"	4"
	F	5/8"	5/8"
	G	8"	8"
	H	16"	16"
	J	3/4"	3/4"
	K	7 1/4"	9"
	L	10"	10"
	M	11"	10 1/4"
	N	22"	17 3/4"

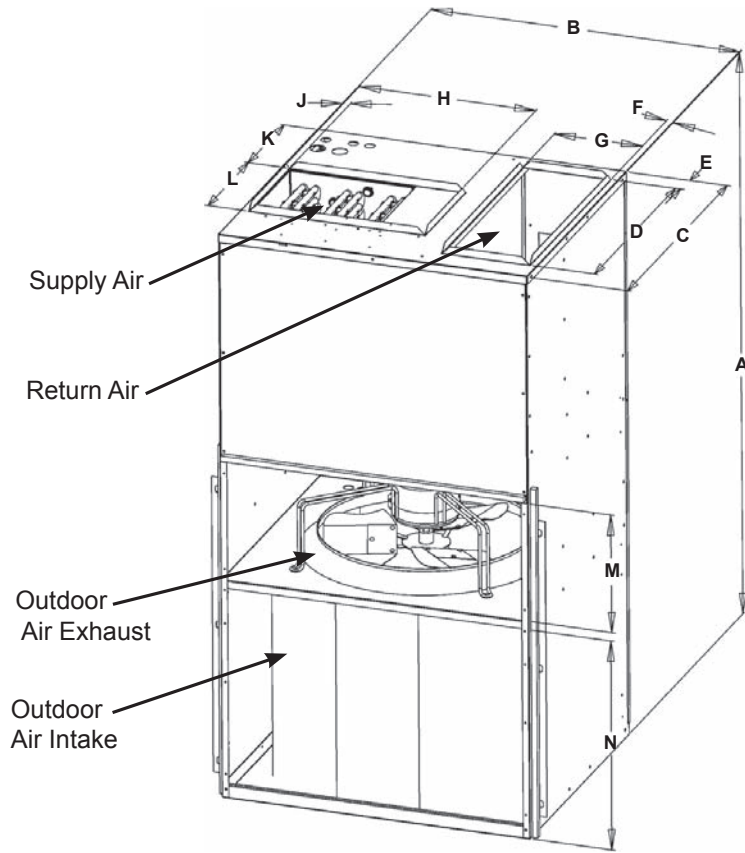

### VPAC/HP 30-36 OPTIONAL ELECTRIC HEAT SPECIFICATIONS

Heater No.	Voltage	Watts	HT. Amps Total	Circuit #1				HT. Amps	Circuit #2		
				HT. Amps	Total	MCA	Max Brkr		Total	MCA	Max Brkr
5	208	4,089	22.7	19.7	22.7	28.4	35*	-	-	-	-
	230	5,000	24.7	21.7	24.7	31.0	35*	-	-	-	-
7.5	208	6,134	32.5	29.5	32.5	40.7	45	-	-	-	-
	230	7,500	35.6	32.6	35.6	44.5	45	-	-	-	-
10	208	8,178	42.3	39.3	42.3	52.9	55	-	-	-	-
	230	10,000	46.5	43.5	46.5	58.1	60	-	-	-	-
15 (VPAC36 only)	208	12,268	62.0	19.7	22.7	28.4	40**	39.3	42.3	52.9	55
	230	15,000	68.2	21.7	24.7	31.0	40**	43.5	46.5	58.1	60

\* VP-30 Requires 35 amp breaker for compressor circuit

\*\* VP-36 Requires 40 amp breaker for compressor (circuit #1)



RETROAIRE

The Right Fit for Comfort

ENVIROMASTER INTERNATIONAL LLC  
5780 Success Drive, Rome, NY 13440  
www.retroaire.com

