

RC/RH24 PACKAGED TERMINAL AIR CONDITIONER/HEAT PUMP

**for New Construction or as a
Replacement for IceCap RSCT Units**

Nominal Capacities:

RC24; 9,000, 12,000, 15,000 & 18,000

RH24; 9,000, 12,000, 15,000 Btuh

RETROAIRE

The Right Fit for Comfort

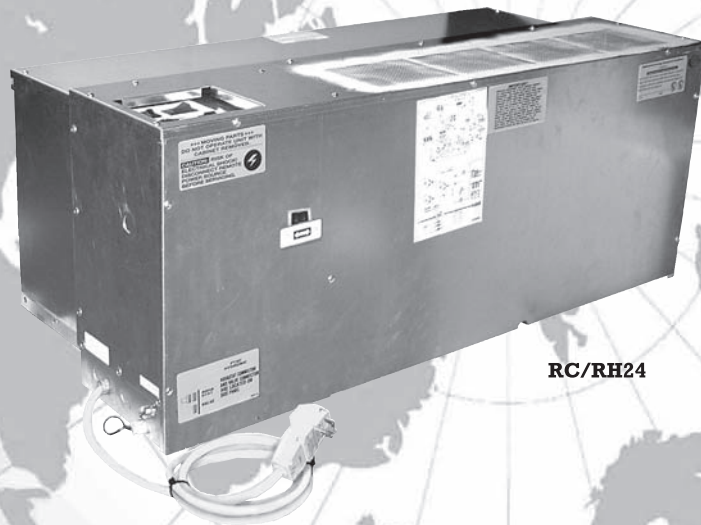

RC/RH24

Enviromaster International LLC
5780 Success Dr.
Rome, NY 13440
www.retroaire.com

An **ECR** International Brand
An ISO 9001-2000 Certified Company



P/N# 240004854, Rev. 1.0 [05/05]

RC/RH24 PACKAGED TERMINAL AIR CONDITIONER/HEAT PUMP

INSTALLATION, OPERATION, AND MAINTENANCE GUIDE

P/N# 240004854, Rev. 1.0 [05/05]

Shipping Damage MUST be Reported to the Carrier IMMEDIATELY!!!
Examine the exterior. Remove cover and examine compressor and piping for signs of damage.

This manual is intended as an aid to qualified service personnel for proper installation, operation, and maintenance of the RetroAire RC/RH24 Packaged Terminal Air Conditioner. Read these instructions thoroughly and carefully before attempting installation or operation. Failure to follow these instructions may result in improper installation, operation, service, or maintenance, possibly resulting in fire, electrical shock, property damage, personal injury, or death.

TO THE INSTALLER

- (1) Retain this manual and warranty for future reference.
- (2) Before leaving the premises, review this manual to be sure the unit has been installed correctly and run the unit for one complete cycle to make sure it functions properly.

To obtain technical service or warranty assistance during or after the installation of this unit, contact your local representative. Visit our website www.retroaire.com for a local representative listing. For further assistance call 1-800-228-9364.

When calling for assistance, please have the following information ready:

- Model Number _____
- Serial Number _____
- Date of installation _____



Recognize this symbol as an indication of important safety information



SAFETY INSTRUCTIONS

- ▲ Read all instructions before using the RetroAire RC/RH24 PTAC. Install or locate this unit only in accordance with these instructions. Use this unit only for its intended use as described in this manual.
- ▲ Check the rating plate on the RetroAire RC/RH24 PTAC before installation to make certain the voltage shown is the same as the electric supply to the unit.
- ▲ The RetroAire RC/RH24 PTAC must be connected only to a properly grounded electrical supply. Do not fail to properly ground this unit.
- ▲ Turn off the electrical supply before servicing the RetroAire RC/RH24 PTAC.
- ▲ Do not use the RetroAire RC/RH24 PTAC if it has damaged wiring, is not working properly, or has been damaged or dropped.

[Save These Instructions]

DANGER

The RetroAire PTAC must:

- ▲ **Be connected to a properly grounded electrical supply with the proper voltage as stated on the rating plate.**
- ▲ **Have proper over current protection (i.e. time-delay fuse/HACR-Breaker) as listed on the Rating Plate.**

Failure to follow these instructions can result in a fire, explosion, or electrical shock causing property damage, personal injury, or death.

TABLE OF CONTENTS

Installer Responsibilities	3
Description, Safety Feature, Warnings	3
Controls and Components	4
Electrical Wiring, Warnings	4
Preparation for Installation	4-5
Installation Instructions	5-6
How It All Fits	6
Final Inspection and Start-Up	7
Sequence of Operation	7-11
Cleaning and Maintenance	12
No Heat Or Cooling!?	12
Specifications	13
Warranty.....	14

INSTALLER RESPONSIBILITIES

This manual has been prepared to acquaint you with the installation, operation and maintenance of the RetroAire RC/RH24 and to provide important safety information in these areas.

We urge you to read all of these instructions thoroughly before attempting the installation or operation of your unit. This manual should be kept for future reference.

The manufacturer of this unit will not be liable for any damages caused by failure to comply with the installation and operating instructions outlined in this manual.

A rating plate identifying your RetroAire RC/RH24 can be found on the unit. When referring to your unit, always have the information listed on the rating plate readily available.

DESCRIPTION

The Retroaire RC/RH24 is designed for use in new construction or as a replacement for the IceCap RSCT Unit packaged terminal air conditioner/heat pump.

The unit is available in cooling only as well as heat pump configurations and will fit into an existing wall sleeve. The RH24 heat pump provides heat when outside temperatures are as low as 40° F.

The RC/RH24 also offers an EER rating as high as 10.0. This can result in immediate energy savings over an older unit. The RC/RH24 features a two speed fan and an outdoor fan that conserves energy by not running in vent or electric heat modes.

Whisper-quiet operation adds to room ambiance and the permanent, washable filter makes service a snap. The 20 gauge, galvanized steel chassis construction ensures long unit life.

All Retroaire products are backed by Enviromaster International LLC and are rated in accordance with ARI Standards 310 and 380 and UL Standard 484.

PRE-INSTALLATION

Test run the RC/RH24 prior to installation. Connect the line cord to a proper power supply (such as the one the old unit is plugged into) and check all controls for proper operation.

MODIFICATION AND TAMPERING



DANGER

Tampering with the RetroAire Dual Motor PTAC is dangerous and may result in serious injury or death. Tampering voids all warranties. Do not attempt to modify or change this unit in any way.

IMPORTANT SAFETY FEATURE

Power Cord With Integral Safety Protection

All PTACs rated 250V or less that are cord connected to the power supply are equipped, with a power cord with integral safety protection as standard. Providing personal shock protection as well as arcing and fire prevention, the device is designed to sense any damage in the line cord and disconnect power before a fire can occur. Tested in accordance with Underwriters Laboratories, the cord set also offers a unique "passive" operation, meaning the unit does not require resetting if main power is interrupted.

WARNING - A DAMAGED POWER SUPPLY CORD MUST BE REPLACED WITH A NEW CORD FROM THE MANUFACTURER, AND NOT REPAIRED.

Each power cord should be checked before every use. Follow the instructions in the order listed on the device.

WARNING - DO NOT USE THE PRODUCT IF THE UNIT FAILS THE TEST.



WARNING

Completely read all instructions prior to assembling, installing, operating, or repairing this product. **Inspect all parts for damage prior to installation and start-up. The RetroAire RC/RH24 PTAC must be installed ONLY by qualified installation personnel.**

CONTROLS AND COMPONENTS

Standard Features

- Unit Mounted Operating Controls
- Thermostat
- Fan Speed Control
- Heat/Cool Switch
- Fan Cycle Switch
- Low Ambient Protection
- Normally Open/Normally Closed Motor Valve-Switch (Hydronic Heat Only)
- Fan Purge
- Indoor Coil Freeze Protection (refer to page 10)
- Anti-Short Cycle Timer and Random Start
- Line Cord with Integral LCDI Protection

Options & Accessories

- Custom Wall Sleeves, Louvers, and Cabinet Enclosures (Consult Factory)
- Remote Thermostat
- Motorized Fresh Air Damper
- Electric Heat (Consult Factory)
- Hydronic Heat (Consult Factory for Coil Availability)
- 115 Volt 09 & 12 (Only) or 265/277 Volt (All Models)

DANGER

The RetroAire RC/RH24 must:

- Be connected to a properly grounded electrical supply with the proper voltage as stated on the rating plate.
- Use the proper maximum over current protection device stated on the rating plate.

The use of extension cords is prohibited.

Failure to follow these instructions can result in a fire, explosion or electrical shock causing property damage, personal injury or death.

DANGER

Do not use the RetroAire RC/RH24 with any electrical supply voltage other than the one listed on the rating plate.

Check the rating plate on the unit for the correct voltage rating. Failure to use the correct voltage may result in death, serious bodily injury or property damage. If you have any questions or doubts, consult the factory before installing this unit.

ELECTRICAL WIRING

CAUTION

To avoid possibility of electric shock and personal injury, disconnect all power to chassis before removing chassis from sleeve or performing any cleaning, servicing, or maintenance.

All wiring should be in accordance with the National Electric Code (NEC) and the local building codes.

1. Inspect the existing wiring for any deficiencies such as cut or frayed wires. Replace such wiring if found.
2. Check the unit rating plate for circuit ampacity and breaker or fuse size. **Use only HACR type breakers.** Select the proper wire for the ampacity rating.
3. If plug and receptacle are used, check the compatibility. The chassis can be hard wired or direct connected as well.
4. Each unit must have a separate branch circuit protected by a fuse or breaker. Refer to the unit rating plate for the proper breaker or fuse size. **Use of extension cords is prohibited.**

WARNING

Moving parts can cause personal injury. Exercise all due caution when test running the chassis.

PREPARATION FOR INSTALLATION

IMPORTANT: RetroAire RC/RH24 are to be used with metal wallsleeves. The sleeves must employ front panels secured by screws that prevent contact with all parts with minor dimensions of openings not exceeding 1/2". The final assembly must employ an indoor air discharge grill having dimensions not less than 26" x 4", separating the top surface of the chassis from the top surface of the discharge grill by a minimum of 1". For all models, the outdoor openings must prevent contact of all moving parts by means of louvers or grills with minor dimension not exceeding 1". All 265 Volt units must be plugged into receptacles within the unit sub-base or chassis.

1. Remove the front of the existing room enclosure. This will expose the old chassis.
2. Disconnect the power supply. If a line cord and plug were used, remove it from the receptacle. If the chassis is hard wired, locate the circuit breaker, place it in the "OFF" position, and tag it, announcing work is being done. **DO NOT TURN ON.**
3. Loosen any tie down bolts or screws and remove the old chassis.

PREPARATION FOR INSTALLATION *Continued*

IMPORTANT: *Dispose of old chassis per present state and federal regulations.*

- Inspect the wall sleeve/cabinet for rust, holes, and damage. Clean the wall sleeve of any dirt, repair any damage, and ensure proper drainage of condensate or rainwater to exterior of building.
- Remove or repair old weather seals and note location for installation of any new seals.
- Check the wall sleeve/cabinet to assure all drain holes are open and that (A) the unit is level left to right and (B) the back is pitched to the outside by 1/2" maximum.
- Check the present voltage to verify the new chassis is a matching voltage and that the line cord and receptacle match.
- Before installing the new chassis, inspect the outdoor louver for a minimum free area of 70% and remove any obstructions. Any variation will restrict air flow over the condenser coil and cause serious damage to the chassis. It will also void the warranty.

⚠ WARNING ⚠

Completely read all instructions prior to assembling, installing, operating, or repairing this product. Inspect all parts for damage prior to installation and start-up. The Retroaire RC/RH24 must be installed ONLY by qualified installation personnel.

INSTALLATION INSTRUCTIONS

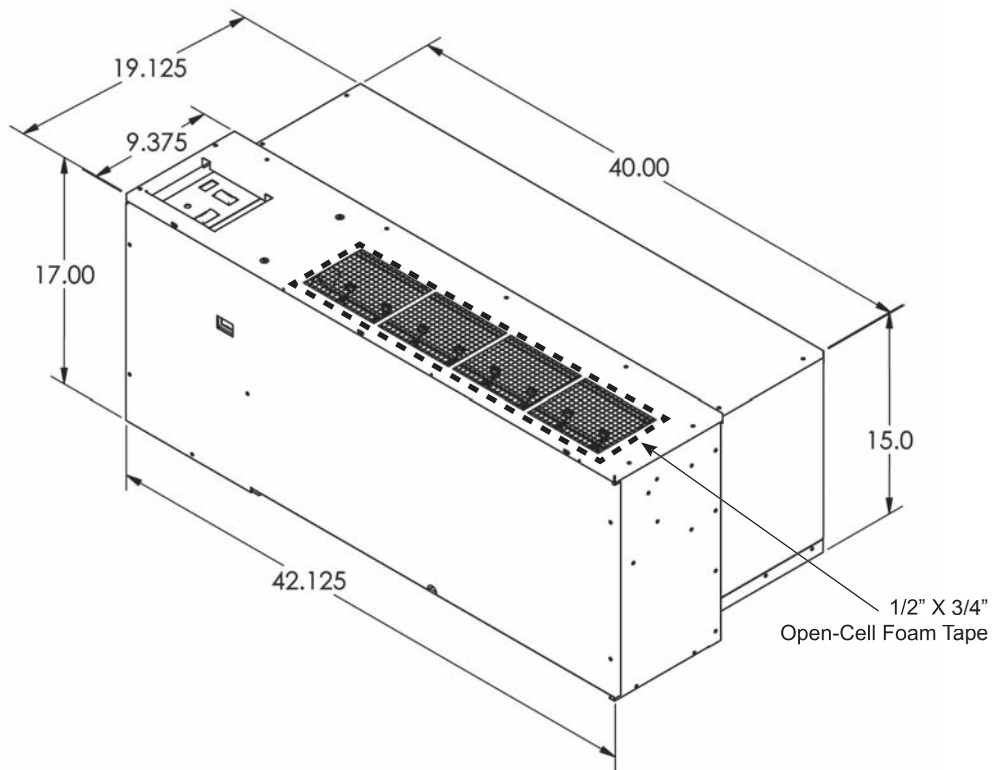

RC/RH24 INSTALLATION KIT

- 1 Installation Manual
- 1/2" x 3/4" Open-cell Foam Tape

HYDRONIC ONLY

- 1ea. 2-Position Connector & Pin Mate
- 14AWG Yellow Wire
- 6' Motor Valve Wire Lead

- Install 1/2" X 3/4" open-cell foam tape around the supply air outlet duct on the top of the unit. See diagram (above).
- Slide unit into wall sleeve. The supply duct on the cooling chassis should line up with the supply vent on the room cabinet.
- Make sure baffles come in contact with the outdoor louver.

(Continued on page 6)

IMPORTANT: Baffles and most of the open-cell foam tape seals are factory installed on the RC/RH24.

Baffles fill the gap between the rear of the chassis and the outdoor louver and prevent the air from recirculating. Consult the factory if baffles supplied are not deep enough to accommodate wall sleeve application as system efficiency and reliability are dependent on proper air flow.

Hydronic Only

Remove the 2-position connector assembly from kit bag supplied with unit (this will have 2 yellow wires attached). Connect this 2-position connector to the 2-position connection located on the left, bottom side of the control box panel.

To Connect Aquastat:

- A. Remove the black jumper wire located on the left, bottom side panel of the control box (this is also terminated with a 2-position connector).
 - B. Cut the jumper wire in the middle and splice the aquastat to the jumper.
 - C. Place the connector back into original location. Refer to wire diagram on the unit for details.
4. Connect line cord.
 5. See Final Inspection and Startup on page 7.

INSTALLATION DIAGRAM

HOW IT ALL FITS

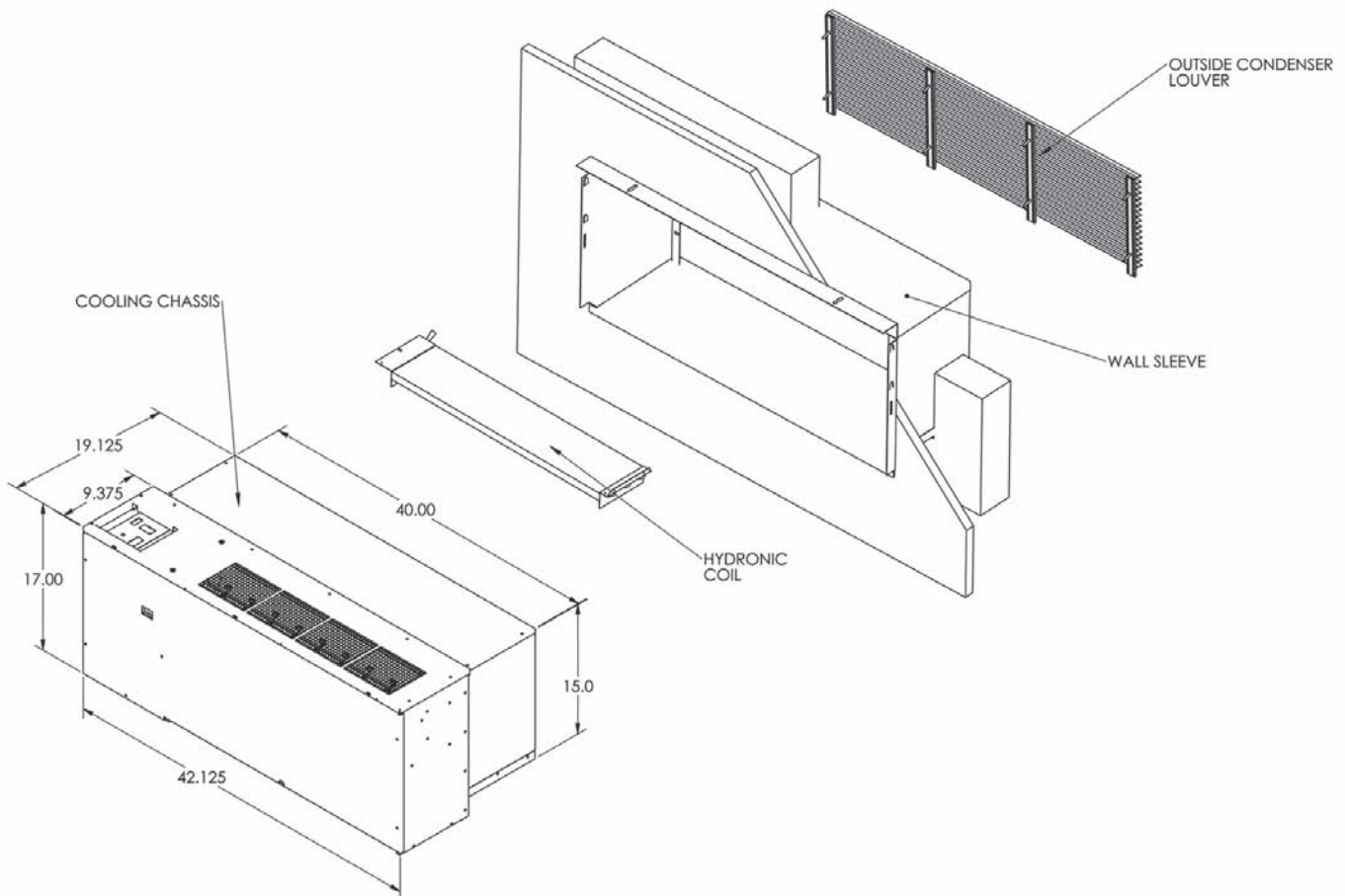

FINAL INSPECTION AND STARTUP

CAUTION

When the unit is first powered up, high humidity conditions can cause condensation to form on the discharge grill. Keep doors and windows closed to reduce humidity and condensation will evaporate.

1. Make sure the chassis is level. Check by pouring water into the drain pan and making certain it flows through the drain hoses to the condenser side of the unit.
2. Plug or hard wire line voltage to unit.

IMPORTANT: Follow the information provided on the rating plate for voltage and amperage/fuse size for proper supply.

3. Attach the front panel to the existing cabinet enclosure.
4. Turn the power on.
5. Check for proper operation (i.e., cooling, optional fresh air, and heating if supplied).
6. Check to be sure nothing will interfere with the room discharge air or the return air to the units (i.e., curtains or drapes that obstruct the air flow or plush carpeting that can obstruct the return air (see below)). Items like these can cause serious damage to the chassis and can void the warranty.

NOTE: Any obstruction of supply air including the use of deflector baffles, may cause condensate to form on the louver or cabinet.

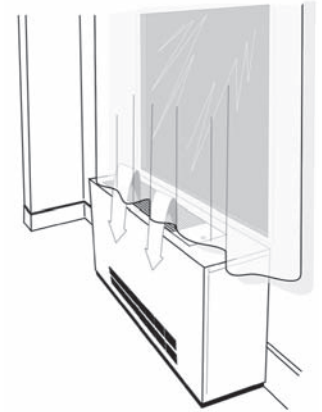

The position of curtains or drapes over supply air grille may cause air to recirculate without cooling the room. The unit will short cycle and may cause premature compressor failure.

- Avoid restricted air flow.
- Allow cool air to circulate throughout the room.

This will ensure optimum performance of your PTAC.

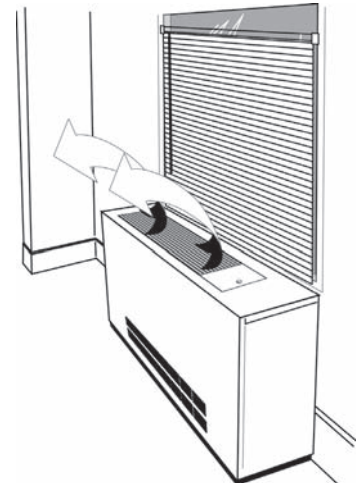

SEQUENCE OF OPERATION

WARNING

To avoid possible injury or death due to electrical shock, open the power supply disconnect switch and secure it in an open position during installation. On a plug and receptacle connection, keep the unit unplugged until installation is complete.

UNIT MOUNTED CONTROLS

RetroAire units with unit mounted controls utilize a mechanical thermostat located on the top of the control section (Figure 1). Turning the unit mounted thermostat knob to the far left will produce the warmest room temperature while turning it all the way to the right will produce the coolest. These settings can be adjusted for personal comfort.

Figure 1

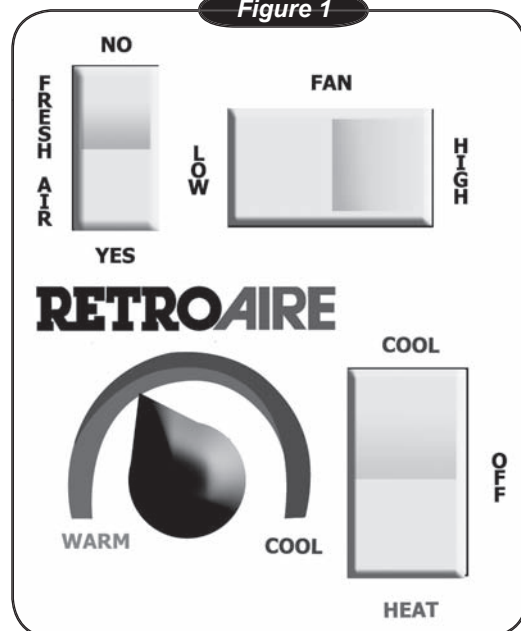

CAUTION

Avoid rotating the thermostat knob back and forth from heating to cooling. This causes the compressor to cycle on and off rapidly and **WILL** cause damage to the compressor. Allow the compressor to remain off for at least three minutes prior to re-starting the unit.

COOLING CYCLE

1. Place system switch in the "COOL" position.
2. Rotate thermostat knob (*below*) clockwise until the compressor fans start running and cold air begins to flow from the unit. For a colder room temperature, continue turning the thermostat knob clockwise and let the unit continue operating to cool the room and remove humidity. If a warmer room temperature is desired, rotate the thermostat knob counter-clockwise until the compressor cycles off.

IMPORTANT: The room temperature must be above 65° F for the compressor to operate.

3. Place system switch in the "OFF" position. All operation should stop.

HEATING CYCLE - ELECTRIC

1. Place system switch in the "HEAT" position.
2. Rotate thermostat knob counter-clockwise until the indoor fans start running and the electric coil starts emitting heat. The condenser fan does not run during the heating cycle unless the chassis is a heat pump. After the unit starts running and the area gets warmer, turn the thermostat knob clockwise until a slight click is heard and the electric heater turns off. If a warmer room temperature is desired, continue turning the knob counter-clockwise and let the unit continue operating. If a cooler room temperature is desired, rotate the thermostat knob clockwise until the electric heater cycles off.

IMPORTANT: Room temperature must be below 85° F to energize the heater.

3. Place system switch in the "OFF" position. All operation should stop.

HYDRONIC COIL

The coil with the old unit can be located under the chassis in a special attachment; or above the chassis in a special attachment. It is necessary to know where the coil is to be

located and the physical size of the coil so the right coil can be supplied if ordered for replacement. The coil is shipped loose for field installation. It should be installed in the same manner as the coil it is replacing. When the hydronic coil is not replaced, installation of the chassis should follow the instructions in this manual.

HEATING CYCLE - HYDRONIC

All straight cool RC Dual Motor PTACs are equipped with a field supplied hydronic heat option. The unit is provided with a two-position molex plug for motor valve connection. To wire this option, take the molex plug connector with (2) yellow wires from the kit and plug it into the molex on the unit. Then wire the opposite end of the molex to the motorized valve in the hydronic circuit.

IMPORTANT: Make sure the motor valve is rated for the correct voltage. Most RetroAire units with unit mount controls will power a valve that is the same voltage as the unit (ex: a unit rated 208/230V will power a 208/230V valve). Be sure to check the wiring diagram (located on the unit) and voltage application for the specific unit. Other valve configurations and voltage options are available. Consult Technical Service if the unit voltage does not match your valve application.

- A. Place system switch in the "HEAT" position.
- B. Turn thermostat knob counter-clockwise. Motorized valve should open and allow hot water to run through the coil. the indoor fans will run, blowing air through the hydronic coil.
- C. Check room comfort level as outlined under "Heating Cycle - Electric."

MOTORIZED FRESH AIR DAMPER (Optional)

The optional motorized fresh air damper allows the operator to move fresh air into the space to be conditioned. This is done by placing the damper door switch in the "YES" position, opening the damper door and allowing fresh air to be moved into the space. To stop the flow of fresh air, simply place the switch in the "NO" position.

CHANGEOVER T-STATS (Heat Pump Only)

On units with a changeover thermostat, the compressor will run until just above freezing (40° F) and then shut off. Electric heat will then energize and assume the heating demand until the temperature of the outdoor air rises to approximately 50° F.

SEQUENCE OF OPERATION *(Continued)*

FAN CYCLE SWITCH

The fan cycle switch allows the operator of the Dual Motor PTAC to have the evaporator fan cycle or run continuously. With the switch in the cycling position the evaporator fan will only run when the unit is calling for heat or cooling. When the switch is in the "ON" position, the evaporator fan will run continuously unless the unit is physically turned off.

CONDENSATE REMOVAL

The Dual Motor PTAC has a drain connection at each end of the condensate drain pan. This allows the condensate to drain through the bulkhead to the area near the condenser fan. The condenser fan has a slinger ring that picks up the condensate and slings it on the hot condenser coil where it evaporates. On heat pump models condensate can form on the outdoor coil during the heat pump cycle. A temperature sensitive valve in the base pan will allow condensate to flow to an internal piping system or external drain kit (supplied by others).

AQUASTAT CONNECTION *(Optional)*

PTACs with hydronic heat option are supplied with a standard high Volt aquastat connection. The connection is located on the bottom or side with a black jumper wire installed in molex. To wire option take jumper wire and cut in half. Then connect 2 field supplied wires to the cut ends of jumper and wire to aquastat (see wiring diagram for more information). If option is not being used simply leave jumper wire connected to unit.

REMOTE THERMOSTAT OPERATIONAL INSTRUCTIONS

CHOOSING A THERMOSTAT

EMI offers a thermostat that is compatible with your PTAC/ PTHP unit. Select EMI part number 240-2960 from the latest Retroaire price list for this option. This is a single stage, cool/heat, mercury bulb thermostat that can be used in all Retroaire cooling, heating or heat pump applications. The thermostat has an adjustable set-point range of between 55°F and 95°F. There are two independent, adjustable stops that can limit the heating or cooling range of the thermostat. If a non-mercury, electronic thermostat is needed, then choose EMI part number 240-3926.

SELECTING A THERMOSTAT *"By Others"*

When selecting a thermostat other than those offered by EMI, it is important to choose a single stage heat/cool, 24V thermostat.

COOLING ONLY WITH ELECTRIC HEAT OR HYDRONIC HEAT. (RC - PTAC'S)

Select a thermostat that is compatible with a cooling - electric heat system. The thermostat should have "R", "Y", "W" and "G" terminals

HEAT PUMP WITH ELECTRIC HEAT. (RH - PTHP'S)

Select a thermostat that is compatible with a cooling - single stage heat - heat pump system. The thermostat should have "R", "Y", "O" and "G" terminals. Retroaire units are single stage heating only. The electric heat and heat pump will not operate simultaneously.

FAN OPERATION

Some thermostats are equipped with an auto/on fan switch. When this switch is placed in the on position the indoor fan will run continuous. When the switch is in the auto position the indoor fan will cycle with the call for heating or cooling.

FAN PURGE

After the room thermostat has been satisfied, the purge feature allows the indoor fan to remain on for an additional 60 seconds. This increases efficiency by pulling the remaining energy from the unit.

COOLING OPERATION

After connecting the thermostat to the unit place the system switch in cool mode. Adjust the set-point temperature below the room temperature. The compressor and fan motors will start and cooling will begin. Place the set-point temperature above the room temperature. The compressor and condenser fan will stop and the indoor fan will remain on for an additional sixty seconds.

NOTE: *The start of the compressor will not take place until the anti-short/random start time period has elapsed.*

ELECTRIC HEAT OPERATION

Place the thermostat system switch in heat mode. Adjust the set-point temperature above the room temperature. The electric heat will energize along with the indoor fan motor. Heating will continue so long as the set-point remains above room temperature. Next place the set-point temperature below room temperature. The Electric heater will switch off and the indoor fan will remain on for an additional sixty seconds.

HYDRONIC HEAT OPERATION *(Optional)*

An optional hydronic heat package may be selected in lieu of electric heat. Heating operation is essentially the same as that of units with electric heat. With the thermostat system switch set to heat and the set-point temperature above room temperature, the hydronic valve will open allowing water to flow through the coil. The indoor fan will also switch on and warm air will flow from the unit. Heating will continue so long as the set-point remains above room temperature. Place the set-point temperature below room temperature. The hydronic valve will close and indoor fan will switch off after the sixty-second purge time has elapsed. The hydronic valve is a 24Vac normally open valve. Should power be lost to the unit, the valve will default to the open position.

HEAT PUMP *(Cooling Mode)*

Cooling operation in a heat pump unit is described in "Cooling operation" above. The unit is equipped with a reversing valve that is energized for cooling and de-energized in heating mode.

HEAT PUMP *(Heating Mode)*

Heat pump units are "Limited Range" equipped with back-up electric resistance heat. Limited Range heat pumps are designed to operate when outdoor temperatures are between 75°F and 40°F and with a maximum indoor temperature of 80°F. When the outdoor temperature falls below approximately 40°F the unit will switch from heat pump to electric resistance heat. Electric heat will then remain as the heat source until the outdoor temperatures rise above 50°F. Retroaire heat pumps (RH – PTHP) are single-stage heating units. The electric heat and heat pump will NOT operate simultaneously.

To operate the unit in heating mode, it must first be connected to an appropriate heat pump thermostat. (See choosing a thermostat). Select heat on the thermostat system switch. Then, adjust the set-point temperature above the room temperature. The compressor and fan motors will start and heating will begin. If the outdoor temperature is below approximately 40°F the heat pump system will not operate. Electric heat will then take over the heating demand. Heating will continue so long as the set-point temperature remains above the room temperature. Place the set-point temperature below the room temperature. The heating mode will cease and the indoor fan will remain on for an additional sixty seconds.

Note: *The start of the compressor will not take place until the anti-short/random start time period has elapsed.*

HEAT PUMP *(Emergency Heat)*

Should the heat pump system fail, it is possible to force the control board into electric heat mode. This is a temporary solution until the heat pump system can be repaired. Locate the circuit board in the control section of the unit. Locate the terminals where the outdoor sensor connects to the circuit board. Using a small needle nose type pliers, disconnect one side of the sensor from the circuit board. This will appear to the circuit board as an outdoor coil freeze condition there-by energizing the electric resistance heater on the call for heat.

HEAT PUMP *(Thermostatic Drain Pan Valve)*

Heat pump units are equipped with a thermostatic drain valve that will open when outdoor temperatures fall below 50°F. This keeps the base pan free of condensate water where it may otherwise freeze during colder outdoor temperatures. As part of its normal operation, the unit will produce condensate and collect it in the base pan of the unit. There it will be picked up by the condenser fan slinger ring and deposited onto the condenser coil. During the cooling season, this improves the unit's efficiency by maintaining adequate refrigeration system pressures.

ANTI-SHORT CYCLE TIMER AND RANDOM START FEATURE

This feature will prevent compressor short cycling and also prevent multiple units in a single facility from simultaneously starting following a power outage. This delay on break feature ensures that the compressor remains off, between cycles, until the three-minute time delay period has elapsed allowing system pressures to equalize before re-starting.

The random start feature, initiated after a power failure, will add a random time delay (between 5-120 seconds) to the three-minute anti short cycle time following a power outage. This will stagger the starting of multiple units in a single facility allowing a building to slowly go back on line when power is restored.

INDOOR COIL FREEZE PROTECTION

This feature will prevent the indoor coil from freeze up in the cooling mode. Indoor coil freeze up can occur due to a dirty air filter, low refrigerant charge or low room or outdoor temperatures. This in turn can cause compressor damage. Should a freeze condition be detected, the compressor and condenser fan will be switched off for a minimum of three minutes and until the freeze condition is satisfied. During this time the indoor fan will continue to run to aid in the defrost process.

SEQUENCE OF OPERATION (Continued)

AJ4004 CONTROL BOARD

There are two sets of jumper pins on the control board that are factory set so there should be no need to set them later on in the field. The first is a set of three pins labeled "HP" for selection of either a "Straight Cool" or "Heat Pump" unit. For "Straight Cool" the center pin and outer most pin (usually on the top) are to be jumped together. For Heat Pump units the center pin and the pin closest to the relay are to be jumped together.

The second is a set of two pins labeled "TEST". When these two pins are jumped together, all timers are eliminated (i.e. anti-short, purge, ect.). This is mainly used for production line testing however it may also be useful for field-testing as well. The units are shipped with the "TEST" jumper on only one of the pins. Please, do not leave a unit with the test jumper in the test mode.

Figure 1

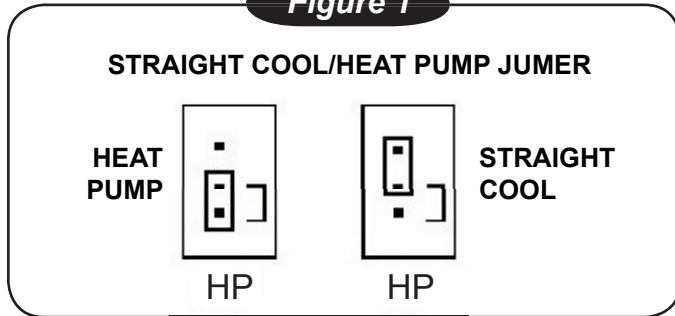
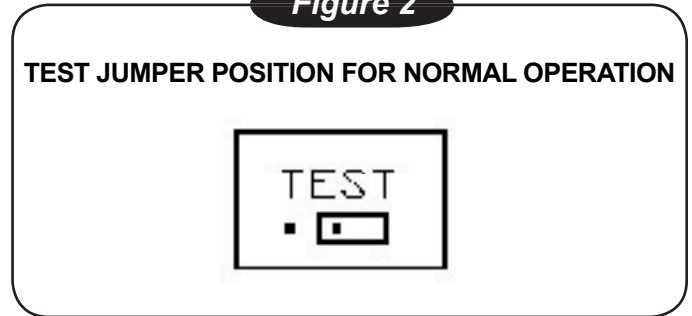

Figure 2



The LED Blink codes are as listed in below.

- 1 Blink Normal Operation
- 2 Blinks Compressor Lockout (ASCT)
- 3 Blinks Outdoor freeze condition
- 4 Blinks Indoor freeze condition
- 5 Blinks Simultaneous W & Y Call

Important sensor resistances are as follows.

- 77 °F - 10K ohms
- 50 °F - 19.9K ohms
- 35 °F - 30K ohms
- 30 °F - 34.4K ohms

CLEANING AND MAINTENANCE

CLEANING THE INTERIOR OF THE UNIT



Before servicing the RetroAire Dual Motor PTAC, be sure to turn off electrical power to the unit. Failure to do so can result in a fire, explosion or electrical shock causing property damage, personal injury or death.

1. Disconnect power from unit.
2. Remove access panels and do a visual inspection of the unit, making sure to check for obvious problems such as damaged coils or evidence of extended wear on any moving part.
3. Check for unusual odors, oil leaks, or stains on or around the coil and refrigerant lines. The presence of oil here may indicate a potentially serious problem such as a refrigerant leak.



It is illegal to discharge refrigerant into the atmosphere. Use proper reclaiming methods and equipment when servicing a RetroAire Dual Motor PTAC.

4. Inspect all electrical connections. Look for frayed wires and poor connections. Terminal ends that are loose will eventually fail, causing a loss of performance or worse.
5. Check fan motors and blower assemblies. Some units may require a drop of light oil to motors and/or bearing assemblies (look for oil cups). Check setscrews and motor mounting hardware, making sure they are tight.
6. Brush and/or vacuum the centrifugal fan blades and blower cage assemblies. These parts must be clean to operate efficiently.
7. Inspect and clean the indoor and outdoor coils, using a fin comb, if necessary, to straighten any damaged fins. these coils must be clean for proper operation.

IMPORTANT: Do not use a solvent-based cleaner on the indoor or outdoor coils. Some solvents can produce a noxious odor when starting the fan or electric heat.

8. Inspect and clean the drain pan and drainline (if any). Use of an anti-fungicide tablet is recommended to keep the condensate system free from bacterial contaminants.
9. Check weep holes along the rear flange of the base pan, making sure they are open.
10. Check the pitch of the unit. Over time the building and equipment may settle, causing a shift in the direction of the condensate flows. Ideally the unit should pitch a minimum of 5° (at least 1/2") to the outside to allow for proper drainage.
11. Replace panels and reconnect electrical power.
12. Test unit operation.

CLEANING THE EXTERIOR

1. Clean the air filter at least once a month by removing it from the unit and washing or vacuuming any dust from its surface. Allowing dust to collect on the filter will cause the PTAC to lose efficiency and eventually malfunction.
2. When cleaning the filter, be sure to vacuum any dust from the return air grille surface as well.
3. Clean exterior of the cabinet as desired with a mild soap or household cleaner.

IMPORTANT: If a new air filter is needed for your RetroAire Dual Motor PTAC, consult factory for availability and/or proper sizing.

NO HEAT OR COOLING!?

Check to see if the unit has power and if the thermostat is satisfied. If the thermostat is not satisfied, refer to the wiring diagram and check control components for continuity.

RC/RH 24 SPECIFICATIONS AND PERFORMANCE DATA

NOTE: Due to EMI's ongoing product development programs, designs, specifications, and performance may change without notice. For more information, please contact the factory.

RC/RH24 Performance Data						
Unit Size	Cooling Btuh	EERs	Heat Pump Btuh	COP	Evaporator CFM Hi/Lo	Fresh Air CFM
09	9,500	10	8500	2.8	440/340	40/35
12	11,900	10	11400	2.9	440/340	40/35
15	14,700	9.2	13800	2.8	500/440	40/35
18	16,900	9.1	N/A	N/A	500/440	40/35

RC24 Hydronic Heat Performance* EMI (single row coil)			
GPM	EWT (°F)	Capacities Btuh	P.D.
3.0	180°F Hi	11,948	2.6
	180°F Lo	11,227	2.6
	140°F Hi	7,526	2.6
	140°F Lo	7,077	2.6

* Performance may vary depending on coil used.

RC/RH24 Electrical Specifications												
Model	Voltage/Hz/Phase	Evap Motor		Cond Motor		Compressor		Total Amps	MCA	Max Fuse	Min Voltage	Line Cord
		FLA	Hp	FLA	Hp	RLA	LRA					
9	115/60/1	1.4	0.09	1.6	0.125	7.4	44	10.4	12.3	15	104	5-15P
	208/230/60/1	0.6	0.08	0.72	0.125	4.1	20	5.4	6.4	15	197	6-15P
	265/60/1	0.67	0.08	0.7	0.125	3.35	18	4.7	5.6	15	240	7-20P
12	115/60/1	1.4	0.09	1.6	0.125	9.7	54	12.7	15.1	20	104	5-20P
	208/230/60/1	0.6	0.08	0.72	0.125	5.1	28	6.4	7.7	15	197	6-15P
	265/60/1	0.67	0.08	0.7	0.125	4.25	26	5.6	6.7	15	240	7-20P
15	208/230/60/1	0.6	0.08	0.72	0.125	6.4	35	7.7	9.3	15	197	6-15P
	265/60/1	0.67	0.08	0.7	0.125	5.4	32	6.8	8.1	15	240	7-20P
18	208/230/60/1	0.6	0.08	0.71	0.09	7.6	45	8.9	10.8	15	197	6-15P
	265/60/1	0.67	0.08	0.71	0.09	6.3	32	7.7	9.3	15	240	7-20P

Note: Data will vary if alternate components (including compressor or motor) are used to meet production needs. Consult factory for current electrical specifications.

RC/RH24 Optional Electric Heat Specifications								
Heater No.	Voltage	Watts	Btuh	Amps	Total Heat Amps	MCA	Max Fuse	Line Cord
2	208	1636	5600	7.9	8.5	10.4	15	6-15P
	230	2000	6900	8.7	9.3	11.5	15	6-15P
	265	2655	9100	10.0	10.7	13.2	15	7-20P
3	208	2454	8400	11.8	12.4	15.3	20	6-20P
	230	3000	10300	13.0	13.6	16.9	20	6-20P
	265	3983	13600	15.0	15.7	19.5	20	7-20P
4	208	3271	11200	15.7	16.3	20.3	25	6-30P
	230	4000	13700	17.4	18.0	22.3	25	6-30P
	265	5310	18200	20.0	20.7	25.7	30	7-30P
5	208	4089	14000	19.7	20.3	25.2	30	6-30P
	230	5000	17100	21.7	22.3	27.8	30	6-30P

NEMA Specifications Non-Locking/Receptacles								
VOLTAGE	125V		250V			265V		
	15(A)	20(A)	15(A)	20(A)	30(A)	15(A)	20(A)	30(A)
PLUS								
RECEPTACLE	5-15 P	5-20 P	6-15 P	6-20 P	6-30 P	7-15 P	7-20 P	7-30 P



ALL PRODUCT LIMITED WARRANTY

Enviromaster International LLC (EMI) warrants to the purchaser/owner that EMI products will be free from defects in material and workmanship under the normal use and maintenance for a period of twelve months for all components and sixty months on unit compressors from the date of original installation, or fifteen months for all components and sixty-three months on unit compressors from the date of manufacture, whichever comes first.

WHAT WE WILL COVER

EMI will replace any defective part returned to EMI's approved service organization with a new or rebuilt part at no charge. The replacement part assumes that unused portion of this warranty.

WHAT WE DON'T COVER

THIS WARRANTY DOES NOT INCLUDE LABOR or other costs incurred for repairing, removing, installing, shipping, servicing, or handling of either defective or replacement parts.

EMI IS NOT RESPONSIBLE FOR:

- Normal maintenance
- Damage or repairs required as a consequence of faulty installation or application by others.
- Failure to start due to voltage conditions, blown fuses, open circuit breakers, or other damages due to the inadequacy or interruption of electrical service.
- Damage or repairs needed as a consequence of any misapplication, abuse, improper servicing, unauthorized alteration, or improper operation.
- Damage as a result of floods, winds, fires, lightening, accidents, corrosive atmosphere, or other conditions beyond the control of EMI.
- Parts not supplied or designated by EMI.
- Products installed outside the United States or Canada.
- Any damages to person or property of whatever kind, direct or indirect, special or consequential, whether resulting from use or loss of use of the product.

LIMITATION OF WARRANTIES

This warranty is exclusive and in lieu of any implied warranties of merchantability and fitness for a particular purpose and all other warranties express or implied. The remedies provided for in this warranty are exclusive and shall constitute the only liabilities on the part of EMI including any statements made by any individual which shall be of no effect.

FOR SERVICE OR REPAIR:

- (1) Contact the Installer
- (2) Call the nearest Distributor
- (3) Call or write:

An **ECR International Brand**
ENVIROMASTER INTERNATIONAL LLC
5780 Success Drive, Rome, NY 13440

