

INSTALLATION, OPERATION AND MAINTENANCE MANUAL

RC85 DOWNFLOW DUCTED PTAC REPLACEMENT

for Chromolox Downflow

STRAIGHT COOL ONLY
Capacities: 9,000-18,000 Btuh

RETROAIRE
The Right Fit for Comfort



RC85

Enviromaster International LLC
5780 Success Dr.
Rome, NY 13440
Phone: 1-800-228-9364
Fax: 1-800-232-9364
Email: info@retroaire.com

An **ECR** International Brand
An ISO 9001-2000 Certified Company



P/N# 240004339, Rev.1.2 [02/05]

RC85 DOWNFLOW DUCTED PTAC

INSTALLATION, OPERATION, AND MAINTENANCE GUIDE

P/N# 240004339, Rev.1.2 [02/05]

Shipping Damage MUST be Reported to the Carrier IMMEDIATELY!!!
Examine the exterior. Remove cover and examine compressor and piping for signs of damage.

This manual is intended as an aid to qualified service personnel for proper installation, operation, and maintenance of the RetroAire RC 85 Downflow Ducted PTAC. Read these instructions thoroughly and carefully before attempting installation or operation. Failure to follow these instructions may result in improper installation, operation, service or maintenance, possibly resulting in fire, electrical shock, property damage, personal injury, or death.

TO THE INSTALLER

- (1) Retain this manual and warranty for future reference.
- (2) Before leaving the premises, review this manual to be sure the unit has been installed correctly and run the unit for one complete cycle to make sure it functions properly.

To obtain technical service or warranty assistance during or after the installation of this unit, contact your local representative. Visit our website www.retroaire.com for a local representative listing. For further assistance call 1-800-228-9364.

When calling for assistance, please have the following information ready:

- Model Number _____
- Serial Number _____
- Date of installation _____

 **Recognize this symbol as an indication of important safety information** 

SAFETY INSTRUCTIONS

- ▲▼ Read all instructions before using the RetroAire RC85 PTAC. Install or locate this unit only in accordance with these instructions. Use this unit only for its intended use as described in this manual.
- ▲▼ Check the rating plate on the RetroAire RC85 PTAC before installation to make certain the voltage shown is the same as the electric supply to the unit.
- ▲▼ The RetroAire RC85 PTAC must be connected only to a properly grounded electrical supply. Do not fail to properly ground this unit.
- ▲▼ Turn off the electrical supply before servicing the RetroAire RC85 PTAC.
- ▲▼ Do not use the RetroAire RC85 PTAC if it has damaged wiring, is not working properly, or has been damaged or dropped.

[Save These Instructions]

DANGER

The RetroAire PTAC must:

- ▲▼ **Be connected to a properly grounded electrical supply with the proper voltage as stated on the rating plate.**
- ▲▼ **Have proper over current protection (i.e. time-delay fuse/HACR-Breaker) as listed on the Rating Plate.**

Failure to follow these instructions can result in a fire, explosion, or electrical shock causing property damage, personal injury, or death.

TABLE OF CONTENTS

To the Installer and Safety Instructions	2,3
Warnings and Installer Responsibilities	3
Controls and Components	4
Product Description	4
Electrical Wiring	4
Installation Instructions	5
Final Inspection and Start-Up	6
Specifications and Dimensions	7
Cleaning and Maintenance, Warranty	8

INSTALLER RESPONSIBILITIES

This manual has been prepared to acquaint you with the installation, operation and maintenance of this RetroAire RC 85 Downflow Ducted PTAC and to provide important safety information in these areas.

We urge you to read all of the instructions thoroughly before attempting the installation or operation of this unit. This manual should be kept for future reference.

The manufacturer of this unit will not be liable for any damages caused by failure to comply with the installation and operating instructions outlined in this manual.

A rating plate identifying this RetroAire RC 85 Downflow Ducted PTAC can be found on the unit. When referring to your unit, always have the information listed on the rating plate readily available.

DANGER

Do not use the RetroAire RC85 Downflow Ducted PTAC. With any electrical supply voltage other than the one listed on the rating plate.

Check the rating plate on the unit for the correct voltage rating. Failure to use the correct voltage may result in death, serious bodily injury or property damage. If you have any questions or doubts, consult the factory before installing this unit.

WARNING

Completely read all instructions prior to assembling, operating, or repairing this product. Inspect all parts for damage prior to installation and start-up. The RetroAire RC 85 Downflow Ducted PTAC must be installed **ONLY** by qualified installation personnel.

MODIFICATION AND TAMPERING

DANGER

Tampering with the RetroAire RC85 Downflow Ducted PTAC is dangerous and may result in serious injury or death. Tampering voids all warranties.

DO NOT ATTEMPT TO MODIFY OR CHANGE THIS UNIT IN ANY WAY.

IMPORTANT NEW SAFETY FEATURE

Power Cord With Intergral Safety Protection

All PTACs rated 250V or less that are cord connected to the power supply are equipped with a power cord with intergral safety protection as standard. Providing personal shock protection as well as arcing and fire prevention, the device is designed to sense any damage in the line cord and disconnect power before a fire can occur. Tested in accordance with Under Writer Laboratories, the cord set also offers a unique "passive" operation, meaning the unit does not require resetting if main power is interrupted.

WARNING - A DAMAGED POWER SUPPLY CORD MUST BE REPLACED WITH A NEW CORD FROM THE MANUFACTURER, AND NOT REPAIRED.

Each power cord should be checked before every use. Follow the instructions in the order listed on the device.

WARNING - DO NOT USE THE PRODUCT IF THE UNIT FAILS THE TEST.

PRODUCT DESCRIPTION

The RetroAire RC85 is a Downflow Ducted PTAC designed for new construction or renovation applications where an alternative to traditional upflow applications is needed (top discharge blocked by curtains, etc.).

Traditionally, through-the-wall air conditioners were positioned below windows with an upflow application but the RC 85 downflow application offers design freedom without sacrificing comfort or economy. The RC85 allows you to duct and deliver air to an adjacent room which allows you to condition two rooms with one unit.

The RC85 Downflow Ducted PTAC is a straight cool only unit available in nominal capacities of 9,000 to 18,000 Btu/h with energy efficiency ratings (E.E.R.) as high as 10.0 at minimal E.S.P. It consists of a two-speed indoor fan and an outdoor fan that conserves energy by not running in vent or heating modes.

Whisper-quiet operation adds to room ambiance and the permanent, washable filter makes service a snap. The 20 gauge galvanized steel chassis construction ensures long unit life.

The RetroAire RC85 Downflow Ducted PTAC is backed by Enviromaster international LLC and is tested and rated in accordance with ARI standards 310 and 380 and UL 484.

CONTROLS AND COMPONENTS

FACTORY INSTALLED OR FIELD SUPPLIED

1. Unit Mounted Operating Control
 - Thermostat
 - Fan Speed Control
 - Heat/Cool Switch
2. Low Ambient Protection
3. Weather Strip Insulation
4. Baffle Kit Bag (supplied)
 - Foam Strip Seal for Supply Air Duct
5. Normally/open normally/closed motor valve-switch, hydronic heat only (standard)

OPTIONAL CONTROLS AND COMPONENTS

1. Remote Thermostat
2. Motorized Fresh Air Damper
3. Fan Cycle Switch
4. Electric Heat (3, 4, or 5kw)

CONSULT FACTORY ABOUT

- Wall Sleeves and Cabinet Enclosures

PRE-INSTALLATION

Test run the RC85 prior to installation. Connect the line cord to a proper power supply (such as the one the old unit is plugged into) and check all controls for proper operation. Disconnect the chassis before installing.



WARNING



Moving parts can cause personal injury. Exercise all due caution when test running the chassis.

REPARATION FOR INSTALLATION

IMPORTANT: The RetroAire RC85 Downflow Ducted PTAC is to be used with a metal wall sleeve. The sleeve must employ front panels secured by screws that prevent contact with all parts with minor dimensions of openings not exceeding 1/2". For all models, the outdoor openings must prevent contact of all moving parts by means of louvers or grills with minor dimension not exceeding 1". All 265 volt units must be plugged into receptacles within the unit sub-base or chassis.

1. Inspect the wall sleeve and ensure proper drainage of condensate or rainwater to exterior of building.
2. Check the wall sleeve to assure all drain holes are open and that (a) the unit is level left to right and (b) the back is pitched to the outside by 1/2" maximum.
3. Check the present voltage to verify the new chassis is a matching voltage and that the line cord and receptacle match.
4. Before installing the chassis, inspect the outdoor louver for a minimum free area of 70% and remove any obstructions. Any variation will restrict air flow over the condenser coil and cause serious damage to the chassis. It will also void the warranty.



WARNING



It is illegal to discharge refrigerant into the atmosphere. Use proper reclaiming methods and equipment when servicing a RetroAire RC85 Downflow Ducted PTAC.



CAUTION



To avoid possibility of electric shock and personal injury, disconnect all power to chassis before removing chassis from sleeve or performing any cleaning, servicing, or maintenance.

ELECTRICAL WIRING

All wiring should be in accordance with the National Electric Code (NEC) and the local building codes.

1. Inspect the existing wiring for any deficiencies such as cut or frayed wires. Replace such wiring if found.
2. Check the unit rating plate for circuit ampacity maximum overcurrent protection. **Use only HACR type breakers.** Select the proper wire for the ampacity rating.
3. If plug and receptacle are used, check the compatibility. The chassis can be hard wired or direct connected as well. An optional receptacle box (J-box) or receptacle with disconnect switch is available.
4. Each unit must have a separate branch circuit protected by a maximum overcurrent device. Refer to the unit rating plate. **Use of extension cords is prohibited.**

INSTALLATION INSTRUCTIONS



CAUTION

Chassis is heavy. To avoid bodily damage, use assistance when lifting.

WALL SLEEVE/CABINET INSTALLATION (New Construction Only)

The wall sleeve is to be built into the wall during construction. The one size wall sleeve is used on all wall thicknesses from 2" to 13".

1. The wall sleeve may be positioned into the wall to suit the application subject to limitations that:
 - The finished inside wall must be a minimum of 10" from the front of the cabinet and 1" from the front of wall sleeve.
 - The outdoor louver must be flush or extending beyond the outside wall (no recess). Use a wall sleeve extension if necessary.
 - The wall sleeve must be rigidly installed into the wall. There are some installations where it may be necessary to anchor the top and sides of the wall sleeve to the wall.
2. For best results, the rear 12" of the cabinet should be supported by concrete regardless of wall (cement slab). The inside must be a minimum of 4" above the finished floor to

allow for proper airflow to the unit. Set the wall sleeve in the wet cement with a 1/4" to 1/2" tilt to the outside and level from left to right. Press into place.

3. The wall sleeve will **NOT** support the wall above it. Provide necessary lintels to prevent distortion or the cabinet. **Do not remove the wall sleeve support until the chassis is to be installed.**
4. Always set the wall sleeve in wet concrete or mortar and press firmly into place to get complete contact between the concrete and the wall sleeve bottom.
5. All cracks or openings between the cabinet and the wall must be filled with mortar and caulked.
6. Receptacle mounting, installation of the junction box, and rough wiring must be complete at the time of the wall sleeve installation. Electrical entrance must be between the concrete, wall sleeve, and the sub-base (if applicable).

EXISTING WALL INSTALLATION

1. Cut an opening in existing wall slightly larger than the wall sleeve. Be sure to locate at least 4" above the finished floor.
2. Follow steps 1-4 in wall sleeve installation.

BAFFLE KIT

Two tight-fit baffles are installed on the condenser coil by screwing them onto the front of the condenser. Point both baffles toward the center of the condenser, then fasten the screws. A second set of baffles will be provided for units that are slightly smaller than the chassis (depth-wise).



WARNING

The correct condenser air baffles must be properly installed or performance will be impaired and/or the warranty will be voided!!

See individual unit installation instructions for more information.

RC 85 DIMENSIONS AND SPECIFICATIONS

IMPORTANT: Due to RetroAire's on going development programs, designs and specifications may change without notice. Please consult factory for the latest information and submittal data before making any job site updates.

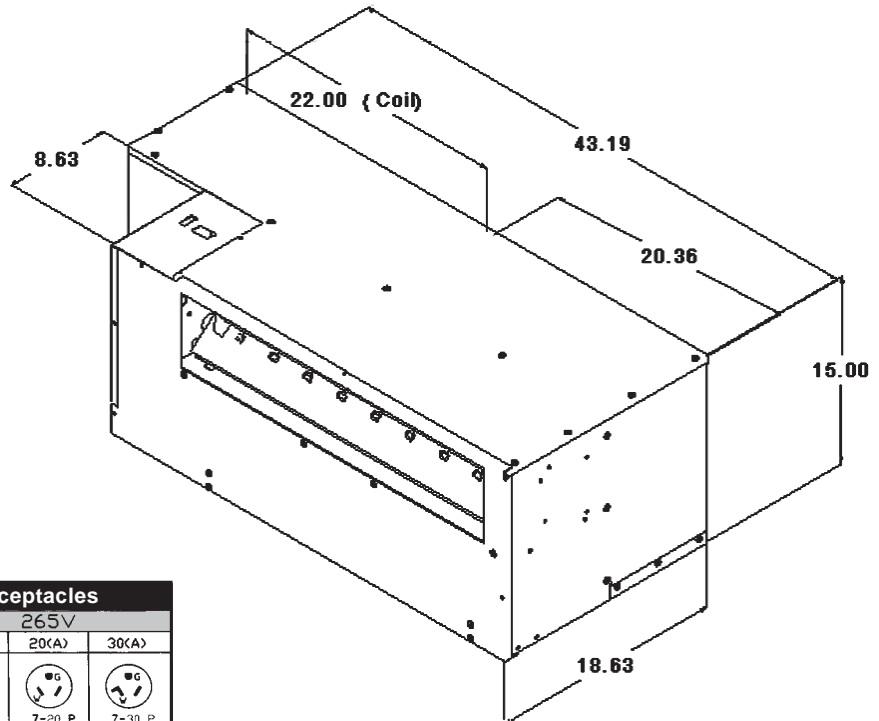

NEMA Specifications Non-Locking/Receptacles								
VOLTAGE	125V		250V			265V		
	15(A)	20(A)	15(A)	20(A)	30(A)	15(A)	20(A)	30(A)
PLUG								
	5-15 P	5-20 P	6-15 P	6-20 P	6-30 P	7-15 P	7-20 P	7-30 P
RECEPTACLE								
	5-15 R	5-20 R	6-15 R	6-20 R	6-30 R	7-15 R	7-20 R	7-30 R

RC85 Electrical Specifications												
Model Number	Voltage/Hz/Phase	Evap Motor		Cond Motor		Compressor		Total Amps	MCA	Max Fuse	Min Voltage	Line Cord
		FLA	HP	FLA	HP	RLA	LRA					
9	115/60/1	1.4	0.09	1.6	0.125	7.4	44	10.4	12.3	15	104	5-15P
	208/230/60/1	0.6	0.08	0.72	0.125	4.1	20	5.4	6.4	15	197	6-15P
	265/60/1	0.67	0.08	0.7	0.125	3.35	18	4.7	5.6	15	240	7-20P
12	115/60/1	1.4	0.09	1.6	0.125	9.7	54	12.7	15.1	20	104	5-20P
	208/230/60/1	0.6	0.08	0.72	0.125	5.1	28	6.4	7.7	15	197	6-15P
	265/60/1	0.67	0.08	0.7	0.125	4.25	26	5.6	6.7	15	240	7-20P
15	208/230/60/1	0.6	0.08	0.72	0.125	6.4	35	7.7	9.3	15	197	6-15P
	265/60/1	0.67	0.08	0.7	0.125	5.4	32	6.8	8.1	15	240	7-20P
18	208/230/60/1	0.6	0.08	0.71	0.09	7.6	45	8.9	10.8	15	197	6-15P
	265/60/1	0.67	0.08	0.71	0.09	6.3	32	7.7	9.3	15	240	7-20P

RC85 Optional Electric Heat Specifications									
Heater No.	Voltage	Watts	Btuh	Amps	Total Heat Amps	MCA	Max Fuse	Line Cord	
2	208	1,636	5,600	7.9	8.5	10.4	15	6-15P	
	230	2,000	6,900	8.7	9.3	11.5	15	6-15P	
	265	2,655	9,100	10	10.7	13.2	15	7-20P	
3	208	2,454	8,400	11.8	12.4	15.3	20	6-20P	
	230	3,000	10,300	13	13.6	16.9	20	6-20P	
	265	3,983	13,600	15	15.7	19.5	20	7-20P	
4	208	3,271	11,200	15.7	16.3	20.3	25	6-30P	
	230	4,000	13,700	17.4	18	22.3	25	6-30P	
	265	5,310	18,200	20	20.7	25.7	30	7-30P	
5	208	4,089	14,000	19.7	20.3	25.2	30	6-30P	
	230	5,000	17,100	21.7	22.3	27.8	30	6-30P	

CHASSIS INSTALLATION

1. Remove packaging from chassis and obtain the kit bag supplied with chassis.
2. Place 1"X1" foam strip on left, top, right side flanges on the condenser side. (Figure 1)

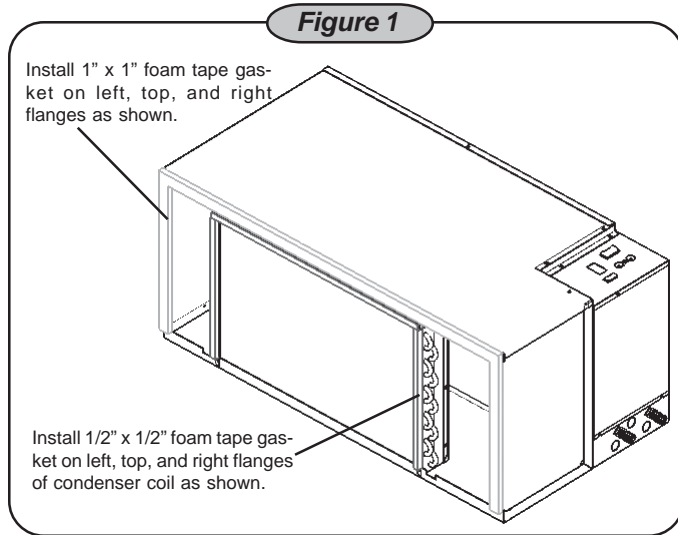

3. Place 1/2"X1/2" foam strips on left, top, right flanges of condenser coil face. (Figures 1 & 2)

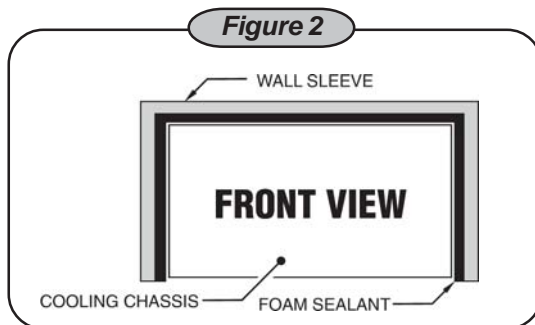

4. Attach (2) zero clearance condenser baffles to condenser coil, left/right side flanges using existing engagement holes on coil end plates. (Figure 3)

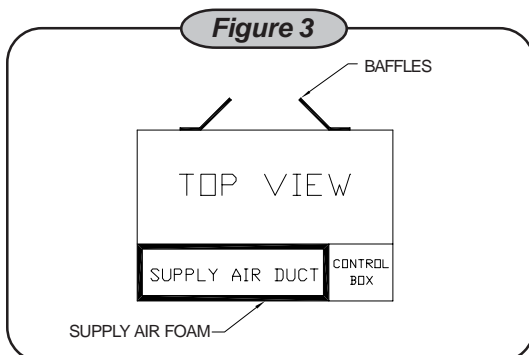

5. After gaskets and condenser baffles are installed, slide chassis into wall sleeve.
6. Position the chassis in the cabinet and slide into place. Keep the chassis level and square to prevent from binding. The chassis must be pushed into the cabinet unit the chassis edges seal firmly against the foam seals.

- Two 16" foam strips of 1/2" x 1/2" closed cell foam tape will be supplied in a kit and applied to the left, right, and top flanges around the condenser coil face.
- A 1" x 1" foam gasket will encompass the three sides of the chassis (left, top and right side flange(s)). This seal is pertinent to sealing the condenser side of the outdoor louver. (Figure 1)

FINAL INSPECTION AND STARTUP

1. Make sure the chassis is level. check by pouring water into the drain pan and making certain it flows through the drain hoses to the condenser side of the unit.
2. Plug or hard wire line voltage to unit.

IMPORTANT: Follow the information provided on the rating plate for voltage and proper maximum over current protection device.

3. Attach the front panel to the cabinet enclosure.
4. Turn the power on.
5. Check for proper operation (i.e., cooling, optional fresh air, and heating if supplied.)
6. Check to be sure nothing will interfere with the room discharge air or return air to the units. Any obstruction could cause serious damage to the chassis and can void the warranty.

SEQUENCE OF OPERATION

UNIT MOUNTED AND REMOTE THERMOSTAT CONTROLS

RetroAire units can be equipped with unit mounted or remote controlled thermostats. Turning the unit mounted thermostat knob to the far Left will produce the warmest room temperature while turning it all the way to the right will produce the coolest. These settings can be adjusted for personal comfort.

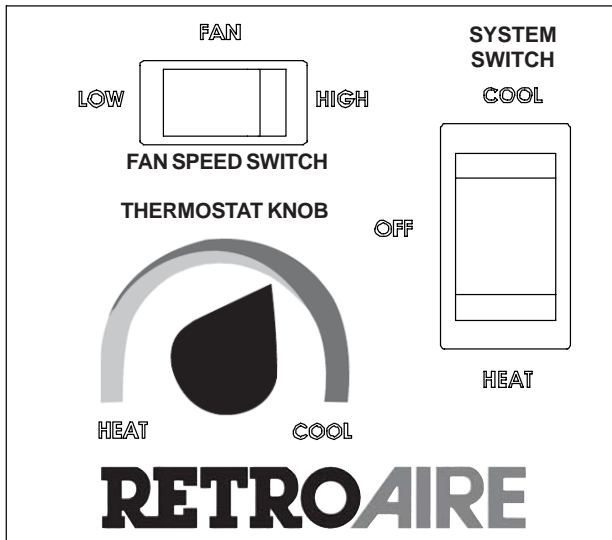

Units with remote thermostats will require operation according to standard thermostat settings. Refer to the operating instructions for the specific thermostat used.

1. Place system switch in the “COOL” position.
2. Rotate thermostat knob (above) clockwise until the compressor fans start running and cold air begins to flow from the unit. For a colder room temperature, continue turning the thermostat knob clockwise and let the unit continue operating to cool the room and remove humidity. If a warmer room temperature is desired, rotate the thermostat knob counterclockwise until the compressor cycles off.

IMPORTANT: The room temperature must be above 65° F for the compressor to operate.

3. Place system switch in the “OFF” position. All operation should stop.

HEATING CYCLE - *Electric*



When the unit is first powered up, high humidity conditions can cause condensation to form on the discharge grill. Keep doors and windows closed to reduce humidity and condensation will evaporate.

1. Place system switch in the “HEAT” position.
2. Rotate thermostat knob counter-clockwise until the indoor fans start running and the electric coil starts emitting heat. The condenser fans do not run during the heating cycle unless the chassis is a heat pump. After the unit starts running and the area gets warmer, turn the thermostat knob clockwise until a slight click is heard and the electric heater turns off. If a warmer room temperature is desired, continue turning the knob counterclockwise and let the unit continue operating. If a cooler room temperature is desired, rotate the thermostat knob clockwise until the electric heater cycles off.

IMPORTANT: Room temperature must be below 85° F to energize the heater.

3. Place system switch in the “OFF” position. All operation should stop.

MOTORIZED FRESH AIR DAMPER (*Optional*)

The optional motorized fresh air damper allows the operator to move fresh air into the space to be conditioned. This is done by placing the damper door switch in the “YES” position, opening the damper door and allowing fresh air to be moved into the space. To stop the flow of fresh air, simply place the switch in the “NO” position.



Avoid rotating the thermostat knob back and forth from heating to cooling. This causes the compressor to cycle on and off rapidly and WILL cause damage to the compressor. Allow the compressor to remain off for at least three minutes prior to restarting the unit.

FAN CYCLE SWITCH

Allows the operator of the RC 85 to have the evaporator fan cycle or run continuously. With the switch in the cycling position the evaporator fan will only run when the unit is calling for heat or cooling. When the switch is in the "constant" position, the evaporator fan will run continuously unless the unit is physically turned off.

CONDENSATE REMOVAL

The RC 95 Downflow Ducted PTAC has a drain connection at each end of the condensate drain pan. This allows the condensate to drain through the bulkhead to the "+" area near the condenser fan. The condenser fan has a slinger ring that picks up the condensate and slings it on the hot condenser coil where it evaporates. On heat pump models condensate can form on the outdoor coil during the heat pump cycle. A temperature sensitive valve in the base pan will allow condensate to flow to an internal piping system or external drain kit (by others).

WALL MOUNTED THERMOSTAT

CHOOSING A THERMOSTAT

EMI offers a thermostat that is compatible with the dual motor package terminal air conditioner. Select EMI part number 240-2960 from the latest RetroAire price list for this option. This is a single stage, cool/heat, mercury bulb thermostat that can be used in all RetroAire cooling, heating or heat pump applications. The thermostat has an adjustable set-point range of between 55°F and 95°F. There are two independent, adjustable stops that can limit the heating or cooling range of the thermostat. If a non-mercury, electronic thermostat is needed, then choose EMI part number 240-3926.

SELECTING A THERMOSTAT "By Others"

When selecting a thermostat other than those offered by EMI, it is important to choose a single stage heat/cool, 24V thermostat.

COOLING ONLY WITH OPTIONAL ELECTRIC HEAT

Select a thermostat that is compatible with a cooling - electric heat system. The thermostat should have "R", "Y", "W" and "G" terminals.

FEATURES OF RETROAIRE DUAL MOTOR PTAC'S

- Microprocessor control board for improved efficiency and system protection
- Fan Operation – Auto/On. High or Low speed fan
- Fan Purge - Fan remains on for 60 seconds after Heat/Cool call is dropped for improved efficiency (Auto mode only)
Universal control board. Circuit board can be used in either a straight cool electric heat or cooling/heat pump application.
- Anti-Short Cycle Compressor Protection.
- Random Start Timer.
- Freeze Protection – Prevents evaporator freeze ups.
- Low Ambient lockout. Compressor prevented from running when outdoor temperatures are too cold for efficient operation.
- Test operation - Allows ease of testing after installation (all timers are eliminated).

FAN OPERATION

Some thermostats are equipped with an **auto/on** fan switch. When this switch is placed in the **on** position the indoor fan will run continuous. When the switch is in the **auto** position the indoor fan will cycle with the call for heating or cooling.

FAN PURGE

After the room thermostat has been satisfied, the purge feature allows the indoor fan to remain on for an additional 60 seconds. This increases efficiency by pulling the remaining energy from the unit.

COOLING OPERATION

After connecting the thermostat to the unit, place the system switch in **cool** mode. Adjust the set-point temperature below the room temperature. The compressor and fan motors will start and cooling will begin. Place the set-point temperature above the room temperature. The compressor and condenser fan will stop. If auto fan mode is selected, the indoor fan will remain on for an additional sixty seconds.

Note: The start of the compressor will not take place until the anti-short/random start time period has elapsed.

ELECTRIC HEAT OPERATION (Optional)

Place the thermostat system switch in **heat mode**. Adjust the set-point temperature above the room temperature. The electric heat will energize along with the indoor fan motor. Heating will continue so long as the set-point remains above room temperature. Next place the set-point temperature below room temperature. The Electric heater will switch off. If auto fan mode is selected, the indoor fan will remain on for an additional sixty seconds.

ANTI-SHORT CYCLE TIMER – RANDOM START FEATURE

This feature will prevent compressor short cycling and also prevent multiple units in a single facility from simultaneously starting following a power outage. This delay on break feature ensures that the compressor remains off, between cycles, until the three-minute time delay period has elapsed allowing system pressures to equalize before re-starting.

NOTE: *The start of the compressor will not take place until the anti-short/random start time period has elapsed.*

The random start feature, initiated after a power failure, will add a random time delay (between 5-120 seconds) to the three-minute anti short cycle time following a power outage. This will stagger the starting of multiple units in a single facility allowing a building to slowly go back on line when power is restored.

INDOOR COIL FREEZE PROTECTION

This feature will prevent the indoor coil from freeze up in the cooling mode. Indoor coil freeze up can occur due to a dirty air filter, low refrigerant charge or low room or outdoor temperatures. This in turn can cause compressor damage. Should a freeze condition be detected, the compressor and condenser fan will be switched off for a minimum of three minutes and until the freeze condition is satisfied. During this time the indoor fan will continue to run to aid in the defrost process.

DISCONNECT SWITCH (Optional)

The disconnect switch will ensure that all power to the control box is removed for servicing.

CLEANING AND MAINTENANCE

WARNING

The RetroAire RC 85 Downflow Ducted PTAC is designed and constructed for reliability and long life with minimal maintenance but service or repairs should **ONLY** be performed by qualified service personnel.

CLEANING THE INTERIOR OF THE UNIT

WARNING

Before accessing the control compartment, disconnect power to the unit. Failure to do so could result in serious injury or electrical shock.

1. Disconnect power from unit.
2. Remove access panels and do a visual inspection of the unit, making sure to check for obvious problems such as damaged coils or evidence of extended wear on any moving part.
3. Check for unusual odors, oil leaks, or stains on or around the coil and refrigerant lines. The presence of oil here may indicate a potentially serious problem such as a refrigerant leak.
4. Inspect all electrical connections. Look for frayed wires and poor connections. Terminal ends that are loose will eventually fail, causing a loss of performance or worse.
5. Check fan motors and blower assemblies. Some units may require a drop of light oil to motors and/or bearing assemblies (look for oil cups). Check setscrews and motor mounting hardware, making sure they are tight.
6. Brush and/or vacuum the centrifugal fan blades and blower cage assemblies. These parts must be clean to operate efficiently.

7. Inspect and clean the indoor and outdoor coils, using a fin comb, if necessary, to straighten any damaged fins. These coils must be clean for proper operation.

IMPORTANT: Do not use a solvent-based cleaner on the indoor or outdoor coils. Some solvents can produce a noxious odor when starting the fan or electric heat.

8. Inspect and clean the drain pan and drain line (if any.) Use of an anti-fungicide tablet is recommended to keep the condensate system free from bacterial contaminants.

9. Check weep holes along the rear flange of the base pan, making sure they are open.

10. Check the pitch of the unit. Over time, the building and equipment may settle, causing a shift in the direction of the condensate flows. Ideally the unit should pitch a minimum of 5° (at least 1/2") to the outside to allow for proper drainage.

11. Replace panels and reconnect electrical power.

12. Test unit operation.

CLEANING THE EXTERIOR OF THE UNIT

1. Clean the air filter at least once a month by removing it from the unit and washing or vacuuming any dust from its surface. Allowing dust to collect on the filter will cause the ptac to lose efficiency and eventually malfunction.

2. When cleaning the filter, be sure to vacuum any dust from the return air grille surface as well.

3. Clean exterior of the cabinet as desired with a mild soap or household cleaner.

IMPORTANT: If a new air filter is needed for your RetroAire RC 85, consult factory for availability and/or proper sizing.

TROUBLESHOOTING

NO HEAT OR COOLING: Check to see if the unit has power and if the thermostat is satisfied. If the thermostat is not satisfied, refer to the wiring diagram and check control components for continuity.

Error Code for LED Blinking	
1 Blink	Normal Operation
2 Blinks	Compressor Lockout
3 Blinks	Outdoor Freeze Condition
4 Blinks	Indoor Freeze Condition
5 Blinks	Simultaneous W & Y Call for Thermostat

Sensor Resistances	
77° F	10K Ohms
50° F	19.9K Ohms
35° F	30K Ohms
30° F	34.4K Ohms



Before servicing the RetroAire Dual Motor PTAC be sure to turn off electrical power to the unit. Failure to do so can result in a fire, explosion or electrical shock causing property damage, personal injury or death.

ALL PRODUCT LIMITED WARRANTY

Enviromaster International LLC (EMI) warrants to the purchaser/owner that EMI products will be free from defects in material and workmanship under the normal use and maintenance for a period of twelve months for all components and sixty months on unit compressors from the date of original installation, or fifteen months for all components and sixty-three months on unit compressors from the date of manufacture, whichever comes first.

WHAT WE WILL COVER

EMI will replace any defective part returned to EMI's approved service organization with a new or rebuilt part at no charge. The replacement part assumes that unused portion of this warranty.

WHAT WE DON'T COVER

THIS WARRANTY DOES NOT INCLUDE LABOR or other costs incurred for repairing, removing, installing, shipping, servicing, or handling of either defective or replacement parts.

EMI IS NOT RESPONSIBLE FOR:

- Normal maintenance
- Damage or repairs required as a consequence of faulty installation or application by others.
- Failure to start due to voltage conditions, blown fuses, open circuit breakers, or other damages due to the inadequacy or interruption of electrical service.
- Damage or repairs needed as a consequence of any misapplication, abuse, improper servicing, unauthorized alteration, or improper operation.
- Damage as a result of floods, winds, fires, lightening, accidents, corrosive atmosphere, or other conditions beyond the control of EMI.
- Parts not supplied or designated by EMI.
- Products installed outside the United States or Canada.
- Any damages to person or property of whatever kind, direct or indirect, special or consequential, whether resulting from use or loss of use of the product.

LIMITATION OF WARRANTIES

This warranty is exclusive and in lieu of any implied warranties of merchantability and fitness for a particular purpose and all other warranties express or implied. The remedies provided for in this warranty are exclusive and shall constitute the only liabilities on the part of EMI including any statements made by any individual which shall be of no effect.

FOR SERVICE OR REPAIR:

- (1) Contact the Installer
- (2) Call the nearest Distributor
- (3) Call or write:

An **ECR International Brand**
ENVIROMASTER INTERNATIONAL LLC
 5780 Success Dr., Rome, NY 13440
 Phone: 1-800-228-9364
 FAX: 1-800-232-9364
 Email: info@retroaire.com