



Comfort Where It Counts.

CACA24 OR CAHA24 WITH S1CA8
Single-Zone Cooling Only

Rev. 1.0 [9/06]

JOB NAME: _____ LOCATION: _____
 PURCHASER: _____
 ENGINEER: _____
 SUBMITTED TO: _____ FOR: REFERENCE [] APPROVAL [] CONSTRUCTION []
 SUBMITTED BY: _____ DATE: _____
 UNIT DESIGNATION: SCHEDULE #: _____ MODEL #: _____



CACA
or
CAHA

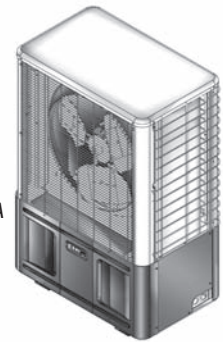

S1CA

▲ **CAPACITIES:**

Cooling..... 18,000 Btuh

Indoor Design Temp °F DB/WB
Cooling..... 80/67

Outdoor Design Temp °F DB/WB
Cooling..... 95/75

▲ **STANDARD FEATURES**

Evaporator – In Ceiling Mounted:

- Connections for 24V remote wall thermostat
- Custom control board with anti-short cycle timer
- Relays and connectors to condensing unit
- Condensate Pump with 36" lift – from base of unit
- 24V Transformer
- Fans are backward curved impeller centrifugal design
- Single fan with aluminum impeller
- Fan purge for improved efficiency
- Freeze protection
- Motors are multispeed, enclosed type w/thermal protection and sealed lifetime bearings
- Permanent, washable filter (user accessible)
- Branch duct knockouts on three sides for remote discharge locations
- Fresh air intake capability on three sides of cabinet
- Four plastic air vanes; motor driven w/auto sweep or fixed position stop setting on models 18-36

Condenser – Side Discharge / Vertically Arranged:

- R-22 refrigerant
- Coated wire guard for coil and fan
- Manual reset high pressure switch

S1CA ELECTRICAL SPECIFICATIONS

Model	Volts/HZ/PH	Total Amps	Min Volt	M.C.A.	HACR BRKR
S1C8D	208/230/60/1	6.2	197	7.6	15

**SYSTEM CAPACITIES
CACA24 OR CAHA24 WITH S1CA8**

Cooling Btuh	SEER	SHR	EER
18,000	13.0	.76	12.3

CACA24 ELECTRICAL SPECIFICATIONS

Volts/HZ/PH	Fan RLA	Heater K.W.	Amps	Total Amps	Min. Volt	M.C.A.	HACR BRKR
208/230/60/1	0.55	–	–	0.6	197	0.7	15
208/230/60/1	0.55	3	13.04	13.6	197	17.0	20

CAHA24 ELECTRICAL SPECIFICATIONS (no electric heat)

208/230/60/1	0.55	–	–	0.6	197	0.7	15
--------------	------	---	---	-----	-----	-----	----

Medium Cabinet

EMI ENGINEERING SUBMITTAL



ARI Standard 210/240 UAC

EMI ENGINEERING SUBMITTAL CACA24 OR CAHA24 WITH S1CA8

CACA & CAHA DIMENSIONS AND SPECIFICATIONS

NOTE: Due to ongoing development programs, design and specifications may change without notice.

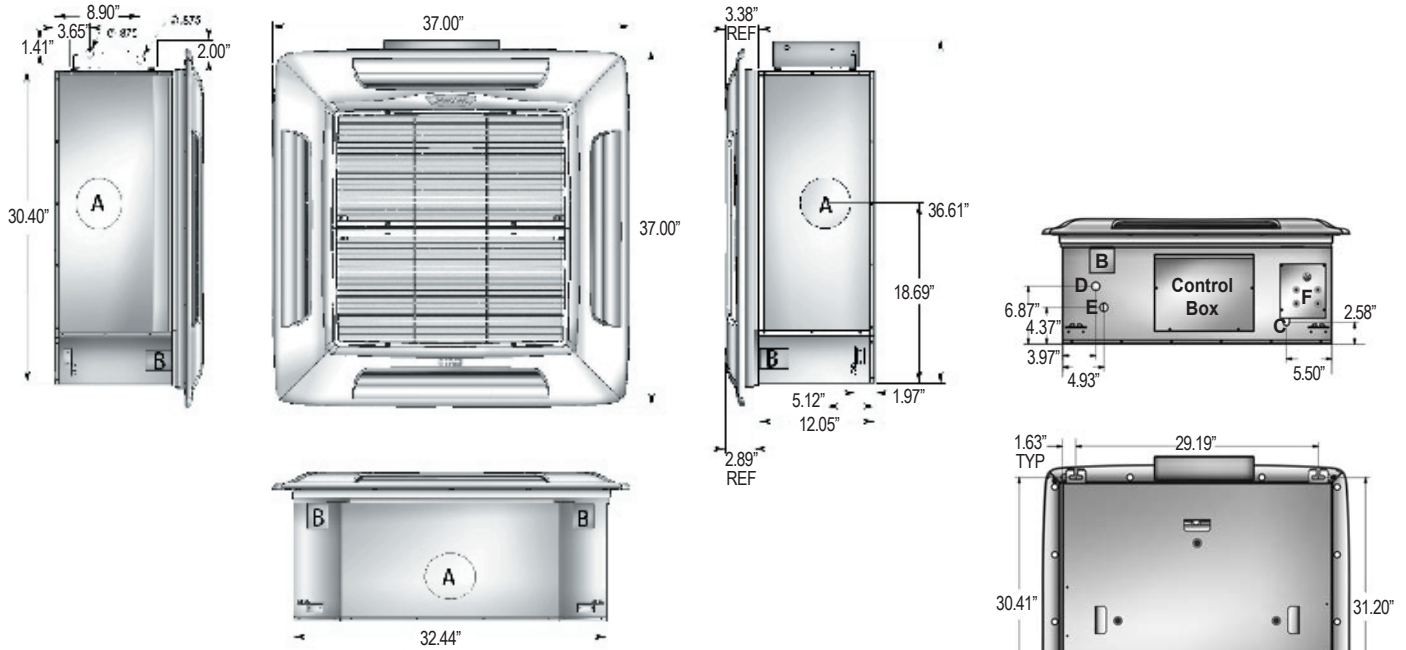

FEATURE	QTY.	SIZE
A	3	5 1/4" Ø
B	2	1 1/4" x 2 1/2"
C	1	1/2" Ø
D	1	1/2" Ø
E	1	1/4" Ø
F	1	-

DISCHARGE AIR VOLUME "Dry Coil"		
Model	High Speed CFM	Low Speed CFM
24	700	620

Model Size	SOUND VALUES		SHIPPING WEIGHT Lbs.
	High	Low	
24	44	42	108

INTERCONNECTING LINE SIZE IN O.D.		
Capacity Btuh	Liquid	Suction
24	3/8"	5/8"*

* Connection is 3/4" O.D. at CACA & CAHA and must be pushed down to interconnect.

S1CA SPECIFICATIONS AND DIMENSIONS

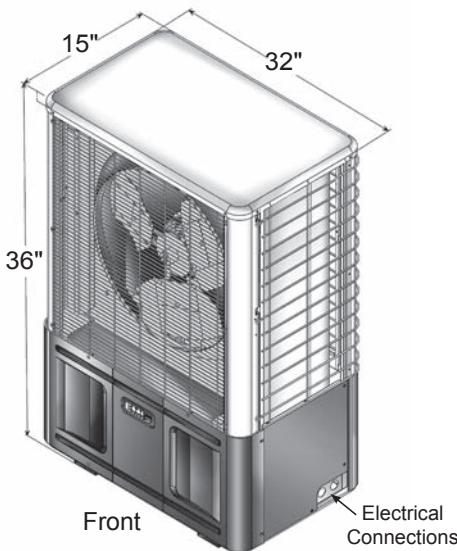

INTERCONNECTING TUBING SPECIFICATIONS					
Model	Max. Length	Max. Lift	Liquid Line O.D.	Suction Line O.D.	Ref.
S1CA8	100'	35'	3/8"	5/8"	R-22

Sound Data		Shipping Weight
Size Btuh	dBA	Lbs.
18	62	156

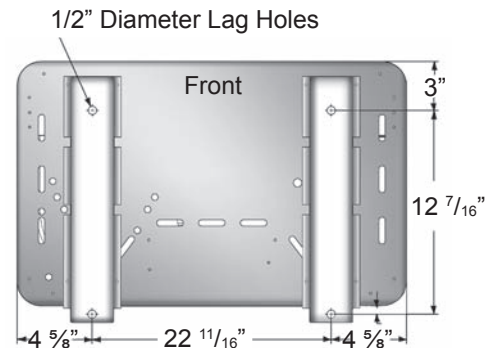

▲ **PART ONE "GENERAL"**

The straight cool air conditioning systems shall be an EMI America Series split system. The system shall consist of a ceiling mounted packaged evaporator section Model CACA24 or CAHA24 and matching America Series outdoor unit Model S1CA8. The units shall be made within North America. The units shall be listed by Intertek Testing Service (ITS) and bear the ETL label. All wiring shall be in accordance with the National Electrical Code (N.E.C.). The units shall be rated in accordance with ARI Standard 210/240 and bear the ARI label. The units shall be manufactured in a facility certified to ISO 9001, which is an international standard used to provide guidance in the development and implementation of an effective Quality Management System. The condensing unit shall contain R-22 refrigerant charge for the evaporator section and condenser section. The system efficiency shall meet or exceed 2006 Federal Standards.

▲ **PART TWO "WARRANTY"**

The units shall have a manufacturer's warranty for a period of (1) year from date of installation. The compressor shall have a warranty of (5) years from date of installation. If, during this period, any part should fail to function properly due to defects in workmanship or material, it shall be replaced or repaired at the discretion of Enviromaster International LLC. This warranty does not include labor. Manufacturer shall have twenty years experience in the U.S. market.

▲ **PART THREE "PERFORMANCE"**

Each indoor unit shall provide at total minimum cooling capacity of 18,000 Btuh with an SEER of 13.0 and EER of 12.3 at ARI standard conditions. The system net minimum total cooling capacity shall be 18,000 Btuh and the net minimum sensible cooling capacity shall be 13,680 Btuh with a circulating air rate of 700 CFM at 80°F (DB)/67°F (WB) entering the indoor coil and 95°F (DB) air entering the outdoor coil. The total power consumption of the combined system shall not exceed 1,463 Watts at these conditions.

▲ **PART FOUR "INDOOR UNIT"**

The indoor unit shall be factory assembled wired and contain a low voltage transformer. The unit shall fit in the ceiling and have the capability of accepting a branch supply duct as well as a fresh air duct. The cabinet shall consist of a galvanized steel sub chassis with fire-resistant thermal and acoustic foam insulation, light grey ABS plastic fascia and manually adjustable discharge louvers that can be placed in a fixed position. Return air shall be filtered by means of an easily removable filter. The evaporator fan shall be backward curved impeller centrifugal design, dynamically and statically balanced, and mounted on integral mounting rails. The evaporator motor shall be multispeed, enclosed type with thermal protection and sealed lifetime bearings. The evaporator coil shall be of nonferrous construction with louvered fins bonded to rifled-copper tubing. The tubing shall have inner grooves for high efficiency heat exchange. All tube joints shall be brazed with phoscopper or silver alloy. The coil shall be pressure tested at the factory. A condensate pan and drain shall be provided under the coil. An integral condensate pump capable of lifting 36 inches shall be provided. System refrigerant flow shall be controlled by means of an orifice piston in the indoor unit. The unit electrical power shall be 208/230 Volts, 1 phase, 60 Hertz. The system shall be capable of satisfactory operation within voltage limits of 208/230 +/- 10% Volts.

▲ **PART FIVE "CONTROL SYSTEM"**

The control system shall consist of 24V Wall Thermostat Control – anti-short cycle compressor protection; fan purge, fan remains on for 60 seconds after heat/cool call is dropped for improved efficiency; integral heating relay ensures that the fan operates whenever electric heat is energized. Wiring shall run from outdoor unit to the 24V wall thermostat and to indoor unit. **NO SPLICES**. When running low Voltage wiring a double insulated 18 awg wire should be used. The control voltage between the indoor unit and the outdoor unit shall be 24 Volts A.C. The 24 Volts shall be generated from the indoor unit's 24 Volt 40VA transformer.

▲ **PART SIX "OUTDOOR UNIT"**

The outdoor unit shall be completely factory assembled, piped and wired. The cabinet shall be fabricated of 18 and 20 gauge aluminized steel, finished in light gray and black corrosion inhibiting polyester powder-coated paint (2000 hour salt spray tested), and a black scratch and dent resistant injection molded front access panel. The unit shall be furnished with one (1) large diameter, direct drive, high efficiency, three blade, propeller type fan. The motor shall be PSC type with internal overload protection, and shall be the permanently lubricated type, and resiliently mounted for quiet operation. The fan shall be provided with a guard to prevent contact with moving parts. The compressor shall be of the high-performance reciprocating or scroll type with a thermal overload. The compressor shall be mounted so as to avoid the transmission of vibration. The condenser shall have easy access hose connections at 45° from valve body. The refrigeration system shall be equipped with a high pressure switch and have the capability to operate with a maximum height difference of 35 feet and overall refrigerant tubing length of 100 feet between indoor and outdoor sections without the need for line size changes or additional oil. The condenser coil shall be U-shaped and protected by a wire coil guard. Construction is seamless copper tubing with enhanced aluminum fins. The tubes are mechanically expanded for secure bonding to fin shoulder. The unit shall be controlled by an electronic circuit board located in the indoor matching unit. The unit electrical power shall be 208/230 Volts, 1 phase, 60 Hertz. The system shall be capable of satisfactory operation within voltage limits of 208/230 Volts +/- 10%.

▲ **PART SEVEN "OPTIONAL EQUIPMENT"**

- **24 Volt Remote Wall Thermostat**
- **3 KW Electric Heat** with automatic reset high temperature cutout and redundant high temperature fuse link
- **32°F Low Ambient Control Kit** – field installed for cooling operation when outdoor temperatures are from 60°F to 32°F, consisting of a fan cycle switch and a crank case heater
- **Wind Baffle Kit** – field installed, consists of a set of louvered panels for the condenser surface areas, which can be left on year round:
 - Wind Baffles in combination with the 32°F Low Ambient Kit will allow the unit to start and run at outside ambient temperatures down to 0°F
 - Wind Baffles also provide an attractive protective covering for the condenser coil surface as well as serving as a hail guard
- **Hard Start** – field installed
- **Copper-Copper Condenser Coils** – for protection against galvanic corrosion
- **Coil Coating Option** – consult factory