



Comfort Where It Counts.

## CAF/CAF4 CHILLED WATER CASSETTE EVAPORATOR

P/N# 240003233 Rev. 1.5 [03/05]



### TWO AND FOUR PIPE FAN COIL W/ELECTRIC HEAT

#### NOMINAL CAPACITIES:

8,000 - 12,000 - 18,000  
20,000 - 33,000 - 36,000 Btuh

### PRODUCT DESCRIPTION

The CAF/CAF4 Chilled Water Cassette Evaporator is available in three cabinet sizes with six cooling output capacities from 8,000-36,000 Btuh. Fan speed adjustments are available in all three cabinet sizes to obtain required performance. Key features include a condensate pump with safety switch and an 18" lift; electric heat; fresh air inlet and branch duct knockouts; and motorized air vanes (18-36 only). The CAF/CAF4 accepts a 24 volt thermostat control (thermostat not included) or an infrared microprocessor control can be obtained as a factory installed option. Hot water coils are available on all CAF4 models in place of electric heat.

Due to ongoing product development, all designs and specifications are subject to change without notice.

### STANDARD FEATURES

▲ **Materials of Construction** - Galvanized steel chassis with fire-resistant thermal and acoustic foam insulation and pearl grey high-impact polystyrene fascia.

#### ▲ **Air Systems:**

- Fans are backward curved impeller centrifugal design; dynamically and statically balanced; and mounted on integral mounting rails.
- Single Fan models (08-20) designed with fire retardant aluminum/plastic impellers.
- Twin Fan models (33-36) designed with fire retardant plastic impellers.
- Motors are multispeed, enclosed type with thermal protection and sealed lifetime bearings.
- Permanent, washable filter (user accessible).
- Branch duct knockouts on two sides for remote discharge locations.
- Fresh air intake capability on three sides of cabinet (2 on CAF 08-12).
- Four flock coated air vanes; motor driven with auto sweep or fixed position stop setting on models 18-36 (models 08-12 equipped with manually adjusted air vanes).

▲ **Coil** - is seamless, rifled copper tubing, arranged in staggered configuration, with enhanced aluminum fins tested to 460 psig. The tubes are mechanically expanded for secure bonding to the fin shoulder.

#### ▲ **Controls and Components (Factory Installed or Supplied):**

- Connections for 24V remote wall thermostat.
- Custom control board featuring anti-short cycle timer, 60 second post purge fan relay, and on-board 30 amp electric heat relay.
- Relays and connectors to condensing unit.
- Electric Heat
  - 1.5KW (8000-12,000 Btuh)
  - 3KW (18,000-20,000 Btuh)
  - 5KW (33,000-36,000 Btuh)
- Condensate pump with 18" lift.
- 24V Transformer.
- Normally-closed relay and connectors to chilled water supply.

#### ▲ **System Options:**

- 24V remote wall thermostat.
- Infrared microprocessor control (factory installed only).

## CAF/CAF4 CASSETTE DIMENSIONS

### SMALL CABINET

- CAF 8,000 - 12,000
- CAF4 8,000 ONLY

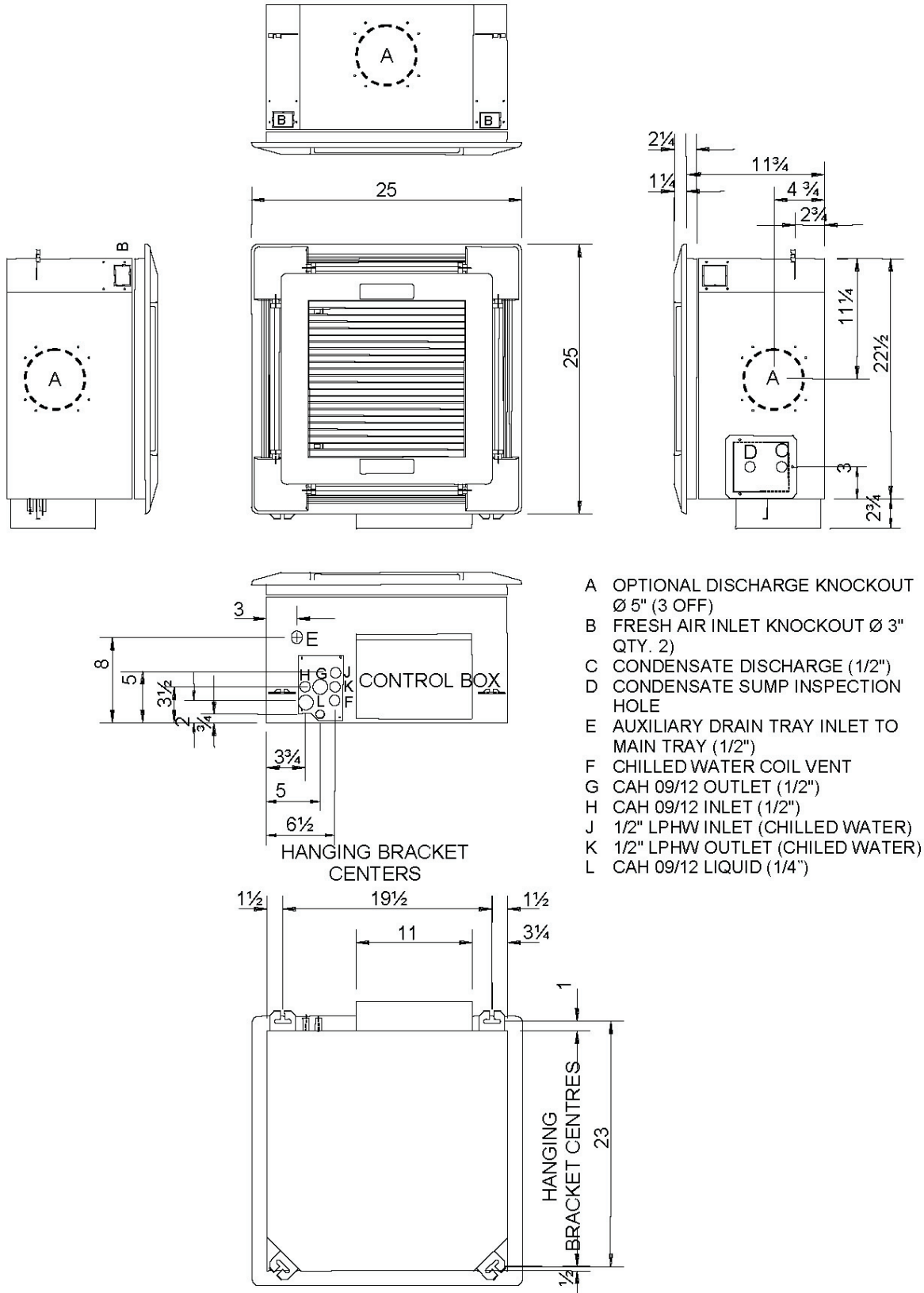

- A OPTIONAL DISCHARGE KNOCKOUT  
Ø 5" (3 OFF)
- B FRESH AIR INLET KNOCKOUT Ø 3"  
QTY. 2)
- C CONDENSATE DISCHARGE (1/2")
- D CONDENSATE SUMP INSPECTION  
HOLE
- E AUXILIARY DRAIN TRAY INLET TO  
MAIN TRAY (1/2")
- F CHILLED WATER COIL VENT
- G CAH 09/12 OUTLET (1/2")
- H CAH 09/12 INLET (1/2")
- J 1/2" LPHW INLET (CHILLED WATER)
- K 1/2" LPHW OUTLET (CHILLED WATER)
- L CAH 09/12 LIQUID (1/4")

## CAF/CAF4 CASSETTE DIMENSIONS

### MEDIUM CABINET

- CAF 18,000 - 20,000
- CAF4 12,000 - 20,000

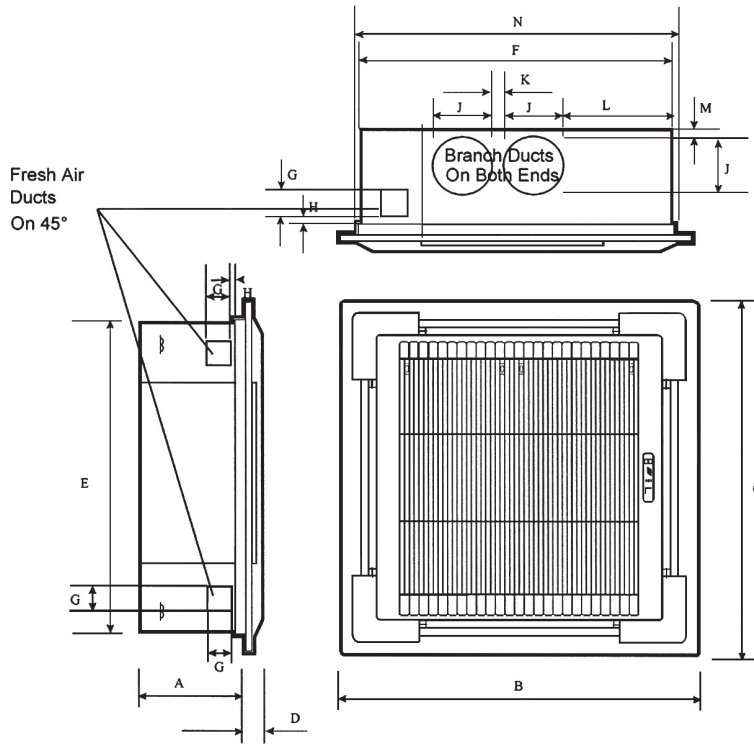

### LARGE CABINET

- CAF/CAF4 33,000 - 36,000

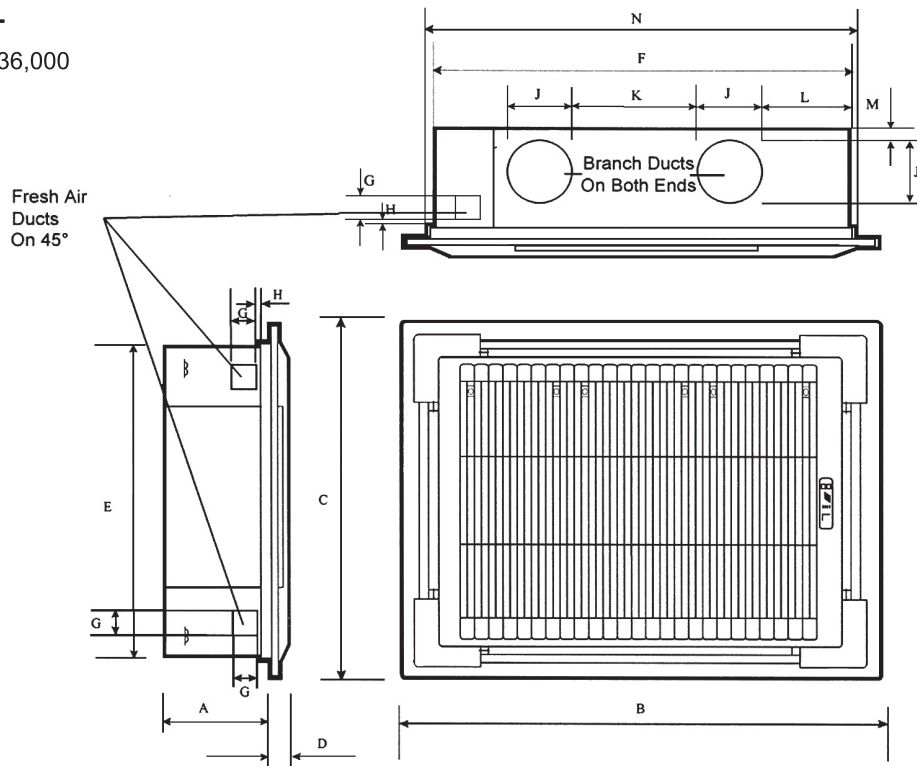

**CASSETTE DIMENSIONS (INCHES)**

SIZE	A	B	C	D	E	F	G	H	J	K	L	M	N
<b>MEDIUM</b>	11	37	37	1¾	32¾	32¾	2¾	½	Ø 5	3¼	9½	¾	33¼
<b>LARGE</b>	13	49¼	37	1¾	32¾	45	2¾	½	Ø 6	13¼	9½	¾	45½

# ELECTRICAL SPECIFICATIONS AND PERFORMANCE DATA

*NOTE: Due to EMI's ongoing product development program, all designs and specifications are subject to change without notice.*

ELECTRICAL SPECIFICATIONS				
STANDARD UNIT DATA		SMALL	MEDIUM	LARGE
POWER SUPPLY		230V/1PH/60HZ	230V/1PH/60HZ	230V/1PH/60HZ
FULL LOAD AMPS	A	0.4	0.6	0.9
MIN. CIRCUIT AMPACITY (MCA)	A	0.5	0.75	1.13
REC. FUSE	A	15	15	15
WITH OPTIONAL ELECTRIC HEAT <sup>1</sup>		SMALL	MEDIUM	LARGE
POWER SUPPLY		230V/1PH/60HZ	230V/1PH/60HZ	230V/1PH/60HZ
ELECTRIC HEAT CAPACITY	KW	1.5	3.0	5.0
HEATER AMPS	A	6.52	13.1	21.7
FULL LOAD AMPS	A	7	13.7	22.6
MIN. CIRCUIT AMPACITY (MCA)	A	8.8	17.1	28.3
REC. FUSE WITH HEAT	A	15	20	30
WITH OPTIONAL BOOST TRANSFORMER <sup>2</sup>		SMALL	MEDIUM	LARGE
POWER SUPPLY		115V/1PH/60HZ	115V/1PH/60HZ	115V/1PH/60HZ
FULL LOAD AMPS	A	0.8	1.2	1.8
MIN. CIRCUIT AMPACITY (MCA)	A	1.0	1.5	2.26
REC. FUSE	A	15	15	15

CAF/CAF4 TECHNICAL DATA			
CABINET DIMENSIONS	SMALL	MEDIUM	LARGE
HEIGHT	10-3/4"	9-1/2"	11-1/2"
WIDTH	22-1/2"	32-1/4"	44-1/2"
DEPTH	22-1/2"	32-1/4"	32-1/4"
WEIGHT	40 LBS.	64 LBS.	97 LBS.
FASCIA DIMENSIONS	SMALL	MEDIUM	LARGE
HEIGHT	2-1/4"	3"	3"
WIDTH	25"	37"	49-1/4"
DEPTH	25"	37"	37"
WEIGHT	5 LBS.	18 LBS.	21 LBS.
CONNECTIONS	SMALL	MEDIUM	LARGE
CHILLED WATER INLET	1/2"	3/4"	3/4"
CHILLED WATER OUTLET	1/2"	3/4"	3/4"
CONDENSATE	1/2"	1/2"	1/2"
BRANCH DUCT DIAMETER	5"	5"	6"
FRESH AIR DUCT DIAMETER	3"	3"	3"
HOT WATER INLET*	1/2"	1/2"	1/2"
HOT WATER OUTLET*	1/2"	1/2"	1/2"
FILTRATION	SMALL	MEDIUM	LARGE
TYPE	WIRE FRAMED PERIFRAME		
QUANTITY	1	2	3
ARRESTANCE	80%	80%	80%
CONDENSATE PUMP	SMALL	MEDIUM	LARGE
MAXIMUM HEAD	18"	18"	18"
NOMINAL FLOW RATE (GPM)	0.1	0.1	0.1

(1) STANDARD UNIT FITTED WITH OPTIONAL ELECTRIC HEATING ELEMENTS. AVAILABLE WITH 230V MODEL UNITS ONLY.

(2) STANDARD UNIT FITTED WITH OPTIONAL BOOST TRANSFORMER FOR CONNECTION TO A 115V ELECTRICAL SUPPLY. ELECTRIC HEAT IS NOT AVAILABLE WITH THIS OPTION.

\* UNITS FITTED WITH OPTIONAL HOT WATER COIL ONLY

SOUND LEVELS (dba)			
Model	High Speed	Med. Speed	Low Speed
8-12	47	45	40
18	43	41	39
20	47	43	41
33-36	48	47	45

DISCHARGE AIR VOLUME			
Model	High Speed CFM	Med. Speed CFM	Low Speed CFM
8-12	400	340	300
18	615	550	490
20	750	615	550
33	996	890	784
36	1123	996	890

CAF4 HOT WATER CASSETTE CAPACITIES (Hot Water 180°F Inlet/160°F Outlet)				
Model	AIR ON °F DB/50% RH	TC Btuh	Flow GPM	P.D. FT. H <sub>2</sub> O
08	50°	19,800	2.0	10.0
	60°	17,100	1.7	8.4
	70°	14,000	1.4	6.7
12	50°	40,600	4.1	9.0
	60°	36,950	3.8	8.1
	70°	33,270	3.4	6.3
18/20	50°	46,060	4.7	10.9
	60°	41,930	4.3	9.4
	70°	37,770	3.8	8.1
33/36	50°	62,500	6.4	10.8
	60°	56,940	5.8	9.2
	70°	51,350	5.2	7.3

CAF CHILLED WATER CASSETTE CAPACITIES									
COOLING CAPACITY		CHILLED WATER INLET/OUTLET °F							
MODEL	AIR ON °F DB/50% RH	40/50° F				45/55° F			
		TC Btuh	SC Btuh	FLOW GPM	P.D. FT. H2O	TC Btuh	SC Btuh	FLOW GPM	P.D. FT. H2O
8	72	5460	5460	1.2	6.7	4780	4440	1.1	5.4
	75	6480	6140	1.4	9.0	5460	5460	1.2	6.4
	80	9550	7170	2.1	17.0	7500	6480	1.7	11.7
12	72	7850	7510	1.7	4.3	6480	6140	1.4	2.7
	75	10580	8190	2.3	6.7	8190	7510	1.8	4.0
	80	14670	9550	3.3	12.0	12280	8530	2.7	8.7
18	72	13480	12520	2.7	3.7	10100	10100	2.0	2.2
	75	17310	13850	3.5	5.8	11670	11640	2.3	3.0
	80	23410	15870	4.7	9.0	17810	13780	3.6	6.0
20	72	15050	14570	3.0	4.6	11670	11630	2.3	3.0
	75	19140	15930	3.8	6.4	13510	13470	2.7	3.7
	80	26650	18390	5.3	11.1	19990	15970	4.0	6.8
33	72	26310	21260	5.3	8.5	17610	17570	3.5	5.3
	75	32070	23500	6.4	13.0	23060	19790	4.6	7.4
	80	41760	26920	8.4	19.2	33130	23300	6.6	14.2
36	72	28490	23300	5.7	10.3	19210	19170	3.8	6.0
	75	34700	25690	6.9	15.1	24910	21700	5.0	8.1
	80	45810	29480	9.2	21.0	35830	25450	7.2	15.7

TC = TOTAL COOLING CAPACITY, SC = SENSIBLE COOLING CAPACITY



Enviromaster International LLC  
5780 Success Drive, Rome, NY 13440  
[www.enviromaster.com](http://www.enviromaster.com)