

SZI Series

Specifications & Submittal Data

12,000 Btuh 16 SEER Single-Zone High Wall DC Inverter Heat Pump Split System

Indoor Air Handler Model:

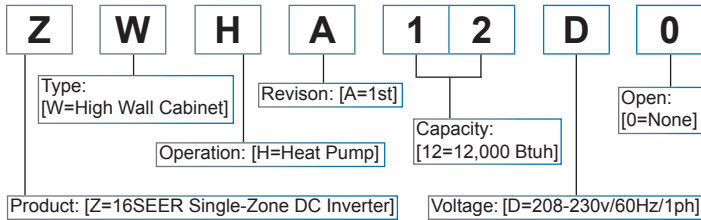

Outdoor Condenser Model:

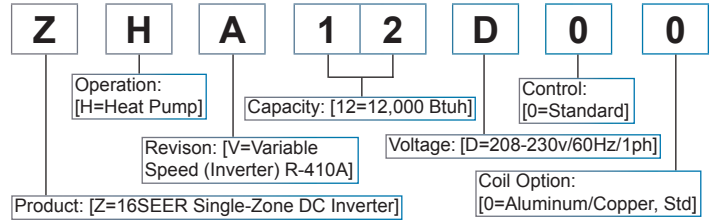

Order Quantity of System	
	12,000 Btuh 16 SEER Single-Zone High Wall, DC Inverter, Heat Pump Split System



Please indicate desired quantity of optional accessories for each system (max allowed)

Condensate Overflow Protection Cut-off Switch, Line Voltage (1)	Refrigerant line set, 8M/26ft, insulated liquid & gas lines. (65' Max EQUIVALENT length & 32' Max Lift)
Mini Condensate Pump Kit, Internal Mount (1)	Refrigerant line set, 15M/49ft, insulated liquid & gas lines. (65' Max EQUIVALENT length & 32' Max Lift)
Undermount Condensate Pump Kit, External Mount (1)	Spare Handheld Infrared Remote Control

NOTE: Every air handler comes with a single handheld infrared remote control

Electrical Specifications									
Model #	Volts/Hz/Ph	Fan Motor		Compressor		Total Amps	Min Volt.	MCA	HACR BRKR
		Amps	Watts	RLA	LRA				
ZHA12D00	208/230/60/1	0.35	72	5.3	N/A	5.65	187	8	15
ZWHA12D0	208/230/60/1	0.28	58.5	-	-	0.28			

Performance — Heat Pump System With High Wall Units									
Condenser	Air Handler	Cooling Btuh(kW)	Heating Btuh(kW)	SEER	HSPF	SHR	EER	COP	Ref.
ZHA12D00	ZWHA12D0	12,000 (3.5)	13,000 (3.8)	16.6	9.2	0.8	12	3.8	R-410A

Standard Low Ambient Operating Range			
Mode		OD Ambient Temp	ID Ambient Temp
Cooling	Max	122°F (50°C) DB	N/A
	Min	5°F (-15°C) DB	63°F (17°C) DB
Heating	Max	93°F (34°C) DB	86°F (30°C) DB
	Min	5°F (-15°C) DB	N/A



To: _____
 Date: _____
 From: _____
 Contact: _____

Project: _____
 Customer: _____
 Location: _____
 Engineer: _____
 Unit Tag# _____

For Your: Reference Approval Construction

Indoor Air Handler & Outdoor Condenser Dimensions

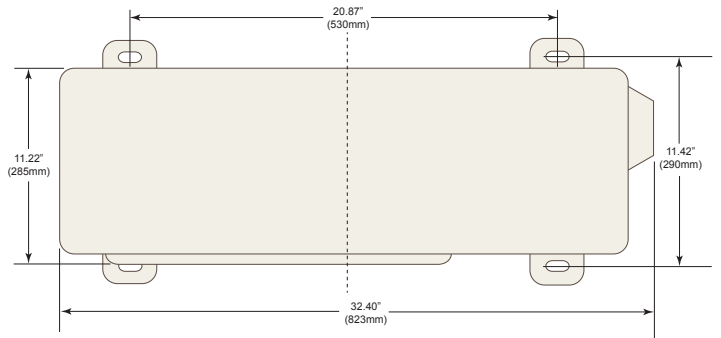
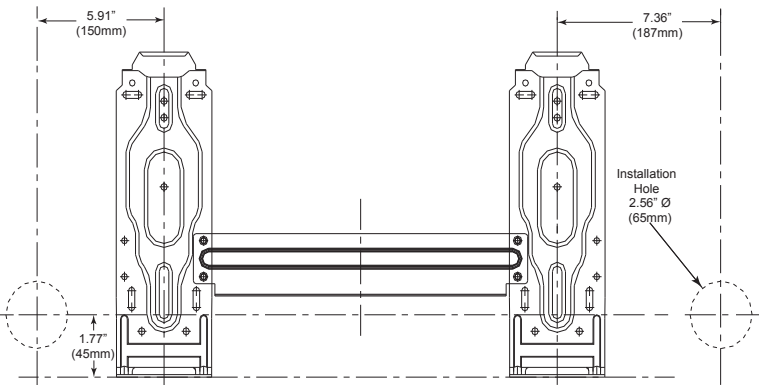
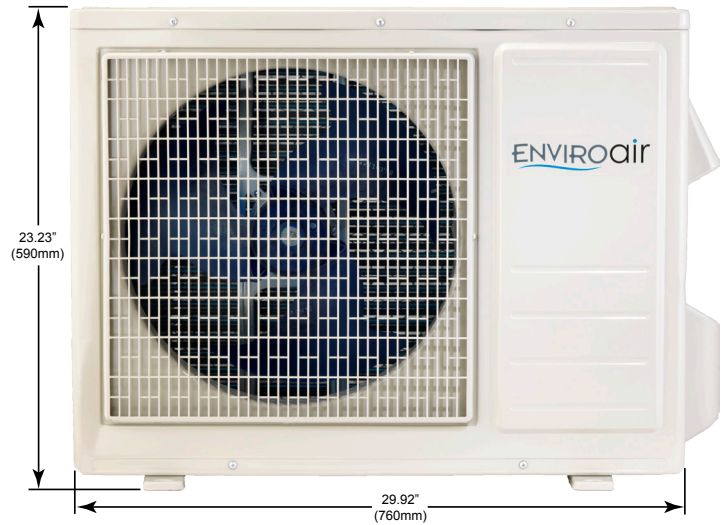
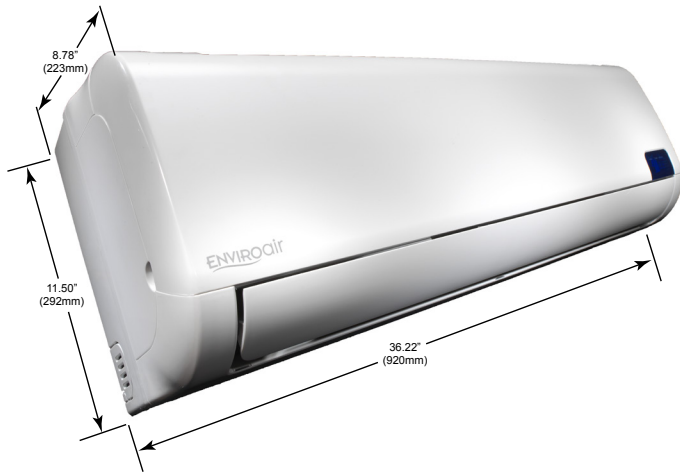

Miscellaneous Product Specifications

Air Handler Air Flow	506 / 465 / 424 CFM	Suction/Gas Connection	1/2" - Flare
Air Handler Sound Level	43 / 41 / 39 dBA	Liquid Connection	1/4" - Flare
Condenser Air Flow	1295 CFM	Coated Coils	NO
Condenser Sound Level	54 dBA	Condenser Weight (net/gross)	88/93 lbs
IR Remote Temp Sensor	YES	Condenser Gross Dimensions	34 15/16" × 25 13/16" × 14"
Turbo Mode	YES	Air Handler Weight (net/gross)	26/33 lbs
24 Hour Timer	YES	Air Handler Gross Dimensions	34 7/8" × 13 3/16" × 10 7/16"
Energy Star Eligible	YES	Air Handler Filter	1 washable mesh
Factory Refrigerant Charge	* 45.15oz (1280g)	Control Wiring (gauge/length)	14AWG/98ft (4-Wire)
Line Set Refrigerant Charge	** 0.215 oz/ft (20 g/m)	Power Wiring (gauge/length)	14AWG or local code
* Total charge for condenser, air handler & 16ft Equivalent length of tubing		Max Equivalent Pipe Length	65ft
** Subtract 16ft from Total Equivalent Length calculation, for factory charge		Max Height (ID to OD unit)	26ft



Enviromaster International

2201 Dwyer Avenue • Utica, New York 13501

Phone: 800.325.5479 • Fax: 866.432.7329

E-Mail: emi@enviromaster.com • Web: www.enviromaster.com



NOTICE: Due to ongoing product development; design, specification and performance data listed within this submittal document are subject to change without notice. For the most current performance data, please refer to ECR International listings of certified products in the AHRI directory, or consult the factory.