



comfortWAVE



CEILING-SUSPENDED AIR HANDLER
(CCP)

**CHILLED WATER
CEILING-SUSPENDED
AND HIGH-WALL
AIR HANDLERS**



HIGH-WALL AIR HANDLER (WCP)

**Installation, Operation
and
Maintenance Manual**



Manufactured by:
ECR International Inc.
2201 Dwyer Avenue, Utica, NY 13501
Tel. 800 253 7900
www.ecrinternational.com
PN 240004373 REV. C [06/01/2020]

TABLE OF CONTENTS

Important Safety Information.....	3
General Product Information	4
EMI Air Handler Family.....	4
Installer Supplied Items	4
Controls And Components	5
High Volt Electrical Wiring.....	5
Low Volt Interconnect	6
DIP Switch Settings	7
Ceiling-Suspended Air Handler CCP.....	8
Ceiling-Suspended Air Handler WCP	10
Start Up Preparation	13
Start-up for Unit Mounted	14
Fan Operation	14
High-Wall Thermostat Control Start-Up	16
Maintenance	18
Troubleshooting.....	18
Troubleshooting Procedure - Error Codes	20
Warranty	21

Report Shipping Damage Carrier

Examine exterior. Remove cover and examine compressor and piping for signs of damage.

Installer:

- (1) Retain this manual and warranty for future reference.
- (2) Before leaving the premises, review this manual to be sure the unit has been installed correctly and run the unit for one complete cycle to make sure it functions properly.

When requesting assistance, please have following information available:

Model Number _____

Serial Number _____

Date of installation _____

Unit has been tested and
rated in accordance with:
ANSI/AHRI Standards
440-2008
UL-1995



Check our website frequently for updates: www.emiretroaire.com

Information and specifications outlined in this manual in effect at the time of printing of this manual. Manufacturer reserves the right to discontinue, change specifications or system design at any time without notice and without incurring any obligation, whatsoever.

IMPORTANT SAFETY INFORMATION

WARNING

Electrical shock hazard. Improper assembly and/or installation could result in death or serious injury. Have a qualified service agency install and service this appliance. Read this manual and understand all requirements before beginning installation.

WARNING

- Install or locate this unit only in accordance with instructions found in this manual. Use this unit only for its intended purpose as described in this manual.
- Connect EMI air handler to properly grounded electrical supply. Do not fail to properly ground this unit.
- Turn off electrical supply before servicing the EMI air handler.
- Do not use EMI air handler if it has damaged wiring, is not working properly, or has been damaged or dropped.



**Become Familiar With Symbols
Identifying Potential Hazards.**

DANGER

Indicates a hazardous situation which, if not avoided, WILL result in death or serious injury.

WARNING

Indicates a hazardous situation which, if not avoided, could result in death or serious injury.

CAUTION

Indicates a hazardous situation which, if not avoided, could result in minor or moderate injury.

NOTICE

Indicates information which should be followed to ensure proper installation and operation.

WARNING

Tampering with this unit is dangerous and could result in serious injury or death. Do not modify or change this unit.

Safety Information

- Have a qualified service agency install and service this appliance.
- Turn off electrical supply before servicing unit.
- Inspect all parts for damage prior to installation and start-up.
- Do not use unit if it has damaged wiring, is not working properly, or has been damaged or dropped.
- Connect to properly grounded electrical supply with proper voltage as stated on rating plate.
- Have proper over-current protection (i.e. time-delay fuse/HACR Breaker) as listed on Rating Plate.
- Verify there are no power feeds to unit such as fire alarm circuits, BMS circuits, etc.
- Service or repair of unit using manufacturer approved replacement parts only.
- Do not use any mechanical or electrical controllers which have been wet. Replace any defective controller.
- Do not support any part of ceiling with appliance, associated wiring or pipe work.
- Check rating plate on unit before installation. Verify voltage shown is same as electric supply to unit. Rating plate is located on top panel.

GENERAL PRODUCT INFORMATION

EMI Air Handler Family

Materials of Construction:

1. Cabinet fabricated of 20-gauge galvanized steel with off-white powder coat matte finish.
2. Plastic tops, fronts constructed of high impact polystyrene (Hips) material.
3. Discharge grill construction of high temperature Noryl plastic (WCP ONLY).
 - Anodized Aluminum discharge grill CCP.
4. Condensate drain pan constructed of anticorrosive G90U galvanized steel.

EMI Air Handler is available as wall or ceiling unit two-pipe chilled water fan coil model. Air handler offers ease of installation, operation, and service. Presently, EMI does not offer a chiller unit that provides chilled water for WCP and CCP models.

EMI Ductless Split System Air Handler Family Consists Of:

WCP: Two-pipe chilled water fan coil wall unit available in 12,000, 18,000, and 30,000 nominal Btuh capacities (hot water coil *not* available).

CCP: Two-pipe chilled water and optional four pipe hydronic heat fan coil ceiling units available in 12,000, 24,000, 30,000 and 48,000 nominal Btuh capacities.

EMI Air Handlers are tested and rated in accordance with UL 1995.

Installer Supplied Items

- Low voltage wiring (18 AWG required)
- High voltage power supply wiring
- Mounting fasteners (screws, wall anchors, etc.)
- Chilled water, condensate piping
- Hot water piping

Installation Considerations

- Determine best location for mounting unit for room air circulation.
- Determine how power wire (high and low voltage) condensate drainage, and water supply piping may be run to and from unit. Knockouts on air handler may be used for this purpose.
- Consider serviceability when locating unit. Cabinet service panels must be able to be removed without obstruction.
- **CCP** - units can be equipped with hot water coil.

Controls And Components *Factory Installed Or Supplied*

Unit mount control panel includes:

- ¾" backlit LCD display
- Adjustable operational range from 55° F to 95° F (in one-degree increments)
- 60 second fan purge
- Freeze protection
- Audio feedback on control setting changes

Fan operation: Auto (cycling), High and Low (constant)

- Dry Mode (operates cooling and electric heat simultaneously to remove humidity when optional electric heat is selected)
- Test Operation for ease of testing after installation (all timers reduced)
- Non-volatile Backup Memory (control settings maintained indefinitely during power outages)
- 24V Low Voltage Transformer

IMPORTANT: *Unit mounted controls are fully functional without the hand-held remote. See page 5*

Optional Controls & Components

- Infrared hand held remote control
- Condensate pump (field or factory installed)
- Chilled water control valve (field installed)
- Wiring for normally closed/power open valve (24V AC, 20VA max. or 8VA max. on units with condensate pumps)
- Open wire electric heaters in 3 sizes (**factory installed ONLY**) with automatic reset high temperature cutout and redundant high temperature fuse link
- Hydronic heat coil with sweat connections (consult factory) CCP only
- 24VAC wall thermostat compatibility

High Volt Electrical Wiring

(SEE THE APPROPRIATE AIR HANDLER SECTION FOR SPECIFIC WIRING INFORMATION.)

All wiring shall be in accordance with the National Electric Code (NEC) and local building codes.

1. Inspect existing wiring for any deficiencies such as cut or frayed wires. Replace such wiring if found.
2. Check unit rating plate for minimum circuit ampacity and breaker or fuse size. **Use only HACR type breakers.** Select proper wire for ampacity rating.
3. Each unit must have separate branch circuit protected by fuse or breaker. Refer to unit rating plate for proper wire and breaker or fuse size.
4. Connect power wire to Black (L1) and other wire to Red/White (L2) at power connector location. Connect ground wire to ground lug or lead at same location in control box.

On units rated 208/230V, primary side of transformer is factory wired for 230V. For 208V power supply, transformer tap must be changed from orange to red. Refer to wiring diagram located on unit.

IMPORTANT: When wiring WCP 18–30 only: If job site voltage is 208V, WCP high-low fan speed switch may be rewired to increase air speed. Replace black and red fan motor wire connections with blue and orange fan motor wires respectively. **See unit wire diagram for specific details.**

LOW VOLT INTERCONNECT WIRING FOR UNIT MOUNTED CONTROLS

24V control transformer is located in air handler unit. This provides low volt control power to air handler . Depending on models selected, **low Volt** interconnect control wiring may be effected.

Note: All low volt interconnect wiring must be at least 18 AWG.

COOLING ONLY UNITS With or Without Heat

Cooling only units utilize two **low Volt** interconnecting wires between the indoor and outdoor units. Wires (WCP) or terminals (CCP) designated “Y” (yellow) and “C” (brown) of the air handler should be connected to the corresponding “Y” (yellow) and “C” (brown) wires or terminals of the condenser. Other wires or terminals such as “R” (red) or “O” (orange) may not be needed and should be protected by a wire nut from making contact with the junction box or other metal surfaces.

Refer to low Volt interconnect diagram interconnect diagram **Figure 1** for unit mounted controls.

Figure 1

CCP/WCP UNIT MOUNT CONTROL

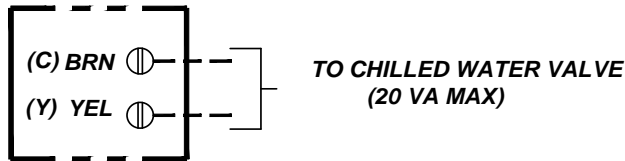

**NEC CLASS 2
LOW VOLTAGE
INTERCONNECT DIAGRAM**

Figure 1A

CCP U/M COOLING/HYDRONIC HEAT

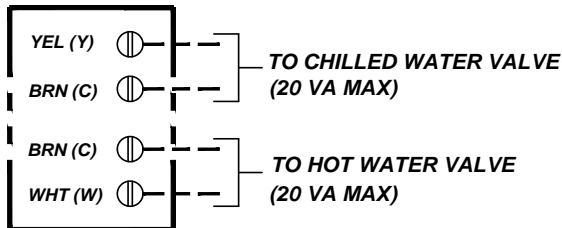

**NEC CLASS 2
LOW VOLTAGE
INTERCONNECT DIAGRAM**

Remote Thermostat Controls

24V control transformer is located in air handler unit. This provides low volt control power to air handler. Depending on models selected, interconnect control wiring may be effected.

All low Volt interconnect wiring must be at least 18 AWG.

Choosing Remote High-Wall Thermostat: See “Wall Thermostat Control” section Pg. 15-16

COOLING ONLY UNITS With or Without Heat

Depending on the thermostat required or selected, cooling only air handles may utilize four to six **low Volt** interconnecting wires between the indoor unit and thermostat. Some thermostats do not require the use of the “C” (brown) connection. In this case, ensure that any unused wires are insulated with a wire nut to prevent them from making contact with the junction box or other metal surfaces.

If the indoor unit has electric heat or hydronic heat then a “W” connection is required between the thermostat and indoor unit.

Refer to low Volt interconnect diagram **Figure 2** for remote wall thermostat controls

**COMMON TO ALL AIR HANDLERS CONTINUED
(SEE PAGE 13 FOR SEQUENCE OF OPERATION)**

DIP SWITCH SETTINGS (Unit Mount Control Only)

Figure 2

CCP RMT HYDRONIC HEAT

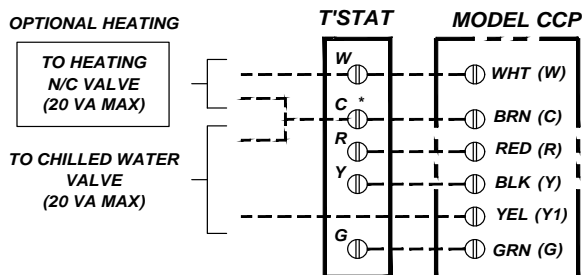

NEC CLASS 2
LOW VOLTAGE CONNECTIONS
*SOME T'STATS MAY NOT
HAVE A "C" TERMINAL

Figure 2 A

CCP/WCP RMT ELECTRIC HEAT

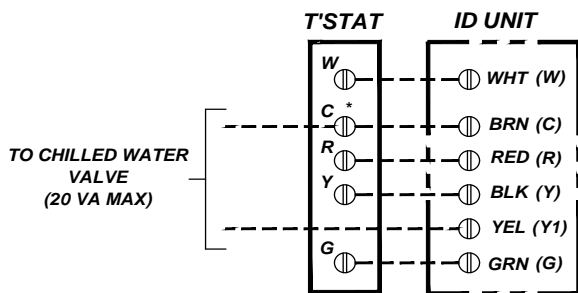

NEC CLASS 2
LOW VOLTAGE CONNECTIONS
*SOME T'STATS MAY NOT
HAVE A "C" TERMINAL

There are two dip switches on the relay board that offer different modes of operation. This allows unit to be matched with either cooling only or cooling with electric heat.

! WARNING

Electrical shock hazard. Before accessing control compartment, disconnect power to indoor unit. **DO NOT** change dipswitch settings with power applied to unit. Failure to follow these instructions could result in death or serious injury.

WCP- to gain access to relay board, remove return air grill from front of unit. Remove any panels or covers to control section. The relay board is located in control box of unit. Set dipswitches (Figure 3) according to table below (Figure 4).

CCP- to gain access to relay board, remove return air grill from bottom of unit. Relay board is located in control section. Set dipswitches (Figure 3) according to table below (Figure 4).

Replace covers after dipswitches are set. Apply power to the equipment.

Figure 3

DIPSWITCH ON RELAY BOARD



Figure 4

DIP SWITCH SETTINGS		
Switch	1	2
Cooling only	Open	Open
Cooling Electric or Hydronic Heat	On	On
Off = Open On = 1 or 2		

CEILING-SUSPENDED AIR HANDLER CCP



Description

- CCP is highly effective ceiling-suspended air handler for applications where fully exposed or partially recessed cabinetry can be used.
- Partially recessed mounting, units easily adapt to standard T-bar, drop-ceiling openings.
- CCP is designed for residential and commercial applications where unit may be concealed in soffits or other structural spaces with only intake and discharge grilles exposed. When concealing unit make provisions to soffit for future access to unit for maintenance purposes.
- When offering Infra-Red Control option, due to infra-red receiver location on the unit, CCP model cannot be mounted in soffit or another structural space.
- Aluminum supply air louvers are dual adjustable for air flow direction, to provide air flow throws to suit any installation. Louvers are mounted in high impact polystyrene front section.
- CCP incorporates dual blowers that produce efficient, quiet operation, suitable for both residential and commercial applications.
- CCP units offer wide range of options, including supplemental electric or hydronic heat options, factory or field installed condensate pump, and optional digital and hand held IR remote controls.
- Hanger brackets and fresh air openings are standard on all models.
- Optional trim kits are available for surface mounting applications.
- ***If equipped with hydronic heat, CCP will only operate as single-stage heating unit and not as two-stage heating unit.***

Optional Controls & Components See page 4 in Common Section for complete list of Optional Controls/Components

Mounting Preparation

Choose best location for unit. Use cardboard template (provided with unit packing) to "test fit" unit before installation

1. CCP Series is designed to be mounted to horizontal surface which should be plumb and level.
2. Using template, mark a spot where piping should penetrate wall.
3. Determine appropriate hole size and cut through mounting surface.

Piping for new construction can be roughed in before wallboard or panels are put in place. PVC pipe may be used as pipe chase.

Mounting

4. Remove access panel, attach front panel and louvers to chassis section with supplied nuts.
5. Front panel shipped separately in cartoning.
6. Secure unit to ceiling using appropriate hardware (screws for wood, anchors for masonry).
7. CCP unit can be ceiling suspended using threaded rods and double nuts to ensure fasteners won't loosen.
8. Pitch unit slightly towards drain for proper condensate removal.

Fresh Air

- 4" round knockout accepts 4" round duct.
- Dampers, wall collars, and outdoor grilles are field supplied. Do not allow moisture or other foreign matter to enter through fresh air intake.
- When ducting, pitch slightly to outside to prevent moisture from entering the chassis.

CCP DIMENSIONS AND SPECIFICATIONS CONTINUED

CCP PHYSICAL DIMENSIONS AND PIPING SPECIFICATIONS								
Model#	Width "A"	Width "B"	Width "C"	Width "D"	Width "E"	Drain Hose	Shipping Wt.	CW Line Size (Supply & Return)
12	42"	16½"	10¾"	41"	5½"	1/2" I.D.	115	1/2" I.D.
24	49"	19"	10¾"	48"	5½"	5/8" I.D.	135	5/8" I.D.
30	49"	19"	10¾"	48"	5½"	5/8" I.D.	135	3/4" I.D.
48	59"	16⅛"	12¾"	58"	7½"	5/8" I.D.	160	3/4" I.D.

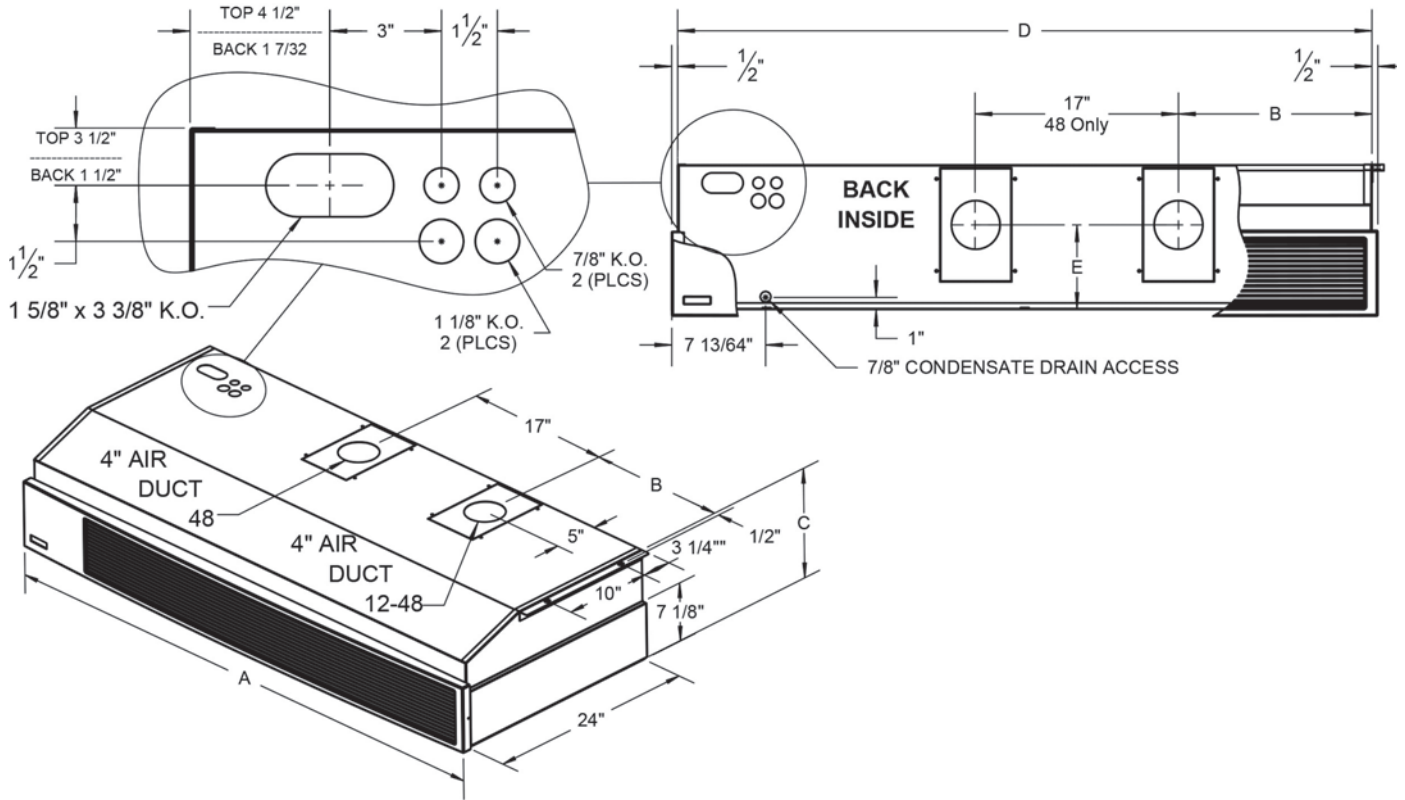

CCP ELECTRICAL SPECIFICATIONS					
Model#	Voltage	Hertz	Fan FLA	Min. Ampacity *(1)	Max. Fuse *(1)
12	115	60	1.4	1.8	15
12	208/230	60	0.6	0.8	15
24	208/230	60	1.1	1.4	15
30	208/230	60	1.1	1.4	15
48	208/230	60	1.1/1.1	2.5	15

*(1) If electric heaters are installed, use Min Amp and Max Fuse from Heater Options Chart.

CCP DISCHARGE AIR SPEED AND THROW				
Model#	cfm	Coil	fpm	Throw/ Ft.
12	350	Dry	290	12.4
18	650	Dry	430	18.6
30	800	Dry	533	18.6
48	1200	Dry	500	19.0

CCP OBSERVED SOUND LEVELS	
Model#	DbA
12	46.3
24	50.8
30	56.0
48	64.2

CCP WITH ELECTRIC HEAT OPTIONS						
Model#	Voltage	kW	Htr Amps	Total Amps	Min. Cir. Amps	Max. Fuse
12	115	0.75	6.5	7.9	9.9	15
12	208/230	3	13.1	13.7	17.1	20
24	208/230	5	21.7	22.8	28.6	30
30	208/230	5	21.7	22.8	28.6	30
48	208/230	7	30.4	32.6	40.8	45

CCP HYDRONIC HEAT SPECIFICATIONS (Single-stage Heating Only)				
Model#	EWT °F	gpm	Btuh	PD Ft. H ₂ O
12	140	2	14,500	3.4
	180	2	22,900	3.4
24	140	4	27,200	5.2
	180	4	43,200	5.2
30	140	4	29,800	5.2
	180	4	47,300	5.2
48	140	4	40,300	6.1
	180	4	64,100	6.1



Refer to Common section of this manual for detailed instructions on:
Controls/Components, Electrical Wiring, Start-Up, and more.

HIGH-WALL AIR HANDLER WCP



Product Description

- WCP is chilled water air handler with contemporary design and attractive appearance to fit any décor.
- Offers high efficiency conditioning of small to mid-size commercial or residential spaces.
- WCP is equipped with unit mounted infrared compatible controls; optional hand held remote is available.
- WCP Chilled Water model provides up to nominal 30,000 Btuh of cooling.
- Electric Heat options are available for up to 5KW of supplemental heat.

Check page 4 in common section of this manual for a list of Optional Controls and Components .

Unit mounted controls are fully functional without remote.

For Consideration

- Check equipment for damage prior to installation. *Foam block has been placed under blower wheel to prevent shipping damage. **Be sure to remove foam block before starting unit.***
- Determine best location for mounting unit and room air circulation.
- Determine how water, condensate, and power line may be run to and from unit.
- Determine if cabinet front can be removed without obstruction.

Mounting Preparation

- Mount WCP plumb and level to vertically square surface to prevent unit vibration and/or unwanted noise.
- Mount WCP directly to smooth surface or sheetrock wallboard or similar material.
- When mounting to block wall, there should be smooth square backing between unit and block surface to absorb potential vibration.
- If excessive noise or vibration is experienced from unit mounted directly to block wall, squareness of wall should be checked immediately.

Unit Mounting

1. Determine best location for unit. Use cardboard template provided in packaging.
2. Mark spot where piping should penetrate wall.
3. Determine appropriate hole size and cut through wall.
4. Piping may be roughed in before wallboard or panels are placed in new construction. PVC pipe (3" or 4" I.D.) may be used as pipe chase.
5. Use supplied wall bracket. Secure bracket to wall with appropriate screws (for wood) or anchors (for masonry).
6. Mount unit to bracket and make certain it fits properly.
7. Wall hanging bracket slot is NOT located in center of unit.

Panels should remain on unit at all times. Service should be performed by Qualified service agency. Annual system check by qualified service technician is recommended.

Refer to common section in front of this manual for more details on: controls/components , electrical wiring, start-up, Operation and Cleaning & Maintenance.

WCP DIMENSIONS AND SPECIFICATIONS

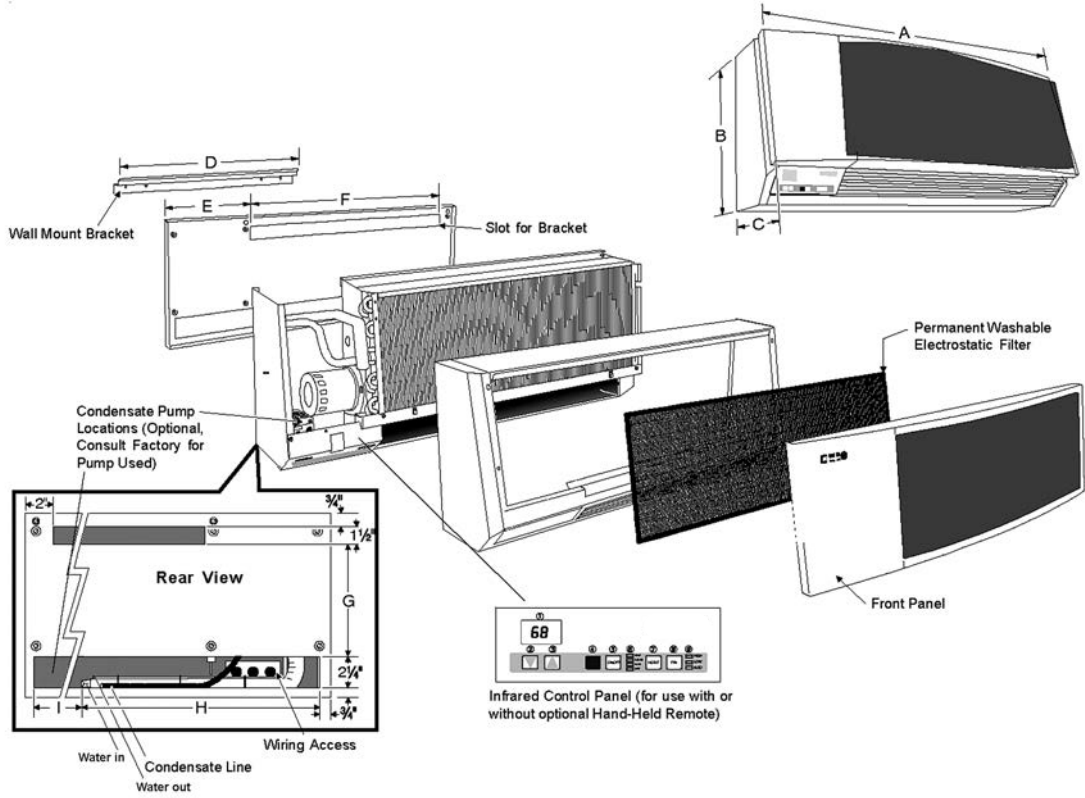

WCP/WCP PHYSICAL DIMENSIONS										
Model	Width "A"	Height "B"	Depth "C"	Width "D"	Width "E"	Width "F"	Width "G"	Width "H"	Width "I"	Shipping Wt.
12	36½"	14½"	10¾"	22"	9"	24½"	8"	18"	16"	85
18	47½"	14½"	10¾"	32"	10"	34½"	8"	18"	27"	115
30	57½"	14½"	10¾"	42"	10"	44½"	8"	27"	28"	115

WCP DIMENSIONS AND SPECIFICATIONS

WCP ELECTRICAL SPECIFICATIONS							
Model #	V/Hz/ph	Fan		Total Amps	Min. Volt	Min. Ampacity (1)	Max Fuse (1)
		FLA	hp				
12	115/60/1	0.64	0.03	0.64	104	0.8	15
	208/230/60/1	0.34	0.02	0.34	197	0.43	15
18	115/60/1	1.2	0.083	1.2	104	1.5	15
	208/230/60/1	0.56	0.07	0.56	197	0.7	15
30	115/60/1	1.2	0.083	1.2	104	1.5	15
	208/230/60/1	0.56	0.07	0.56	197	0.7	15

(1) If electric heaters are installed, use Min Amp and Max Fuse from Heater Options Chart.

WCP ELECTRIC HEAT OPTIONS						
Model	Voltage	kW	Heater Amps	Total Amps	Min. Cir. Amps	Max Fuse
12	115	0.75	6.5	7.1	8.9	15
12	230	3	13.1	13.5	16.8	20
18	115	0.75	6.5	7.7	9.6	15
18	230	3	13.1	13.6	17	20
30	115	1.25	10.9	12.1	15.1	20
30	230	5	21.7	22.3	27.9	30

DISCHARGE AIR SPEED AND FLOW (230V High Speed Fan)				
Model	cfm	Coil	fpm	Throw/Ft.
12	310	Dry	960	16
18	600	Dry	1412	26
30	750	Dry	1400	25

WCP CAPACITIES						
Model	Nominal Capacities	Total Capacity	Sensible Capacity	Fluid Temp.	Fluid Flow	PD Ft. H ₂ O
12	9,000	7,375	6,732	45	1	0.8
		10,801	8,272	45	2	3.8
		13,270	9,279	45	3	8.0
	12,000	8,387	7,189	40	1	0.8
		12,481	8,950	40	2	3.9
		15,643	10,304	40	3	8.1
18	15,000	15,624	13,477	45	2	4.4
		19,761	15,367	45	3	9.1
	18,000	17,724	14,379	40	2	4.5
		23,073	16,763	40	3	9.3
30	24,000	20,563	17,564	45	3	2.3
		29,031	21,178	45	6	8.3
		32,320	22,539	45	9	17.7
	30,000	23,600	18,887	40	3	2.4
		34,400	23,423	40	6	8.4
		38,790	25,351	40	9	17.9

WCP OBSERVED SOUND VALUES (230V High Speed Fan)	
Model	DbA
12	48
18	51
30	54

CONNECTIONS		
WCP		
Model	Chilled Line Size	Drain Size
12	1/2" I.D.	1/2" I.D.
18	5/8" I.D.	1/2" I.D.
30	5/8" I.D.	1/2" I.D.



Start Up Preparation

See "Common" section of this manual (on page 13-16) for control details.

- Confirm dip switch settings are correct for your unit
(see page 6)
- Remove any tools or other obstructions
- Be sure the filter is in place
- Verify unit is level
- Separate any lines that contact each other
- Replace cabinet front onto chassis

Test each power and circuit connection before powering up system. Use unit mounted electronic thermostat controls to start system. (See Operating Instructions on Control) Operation Section, Thermostat, Unit Mount or Remote.)

Initial Start-up - Unit mount controls only

Infrared Control Operation

- EMI Air Handlers are equipped with a unit mount, infrared compatible control package (optional on CCP).
- User friendly, microprocessor control is designed to protect system.
- Unit operation can be made by ***either keypad on unit or by using optional hand held infrared controller***
- There are two dipswitches on relay board that offer different modes of operation. This allows unit to be operated as either cooling only or cooling/heating

Unit will start in time delay. These are default settings of unit mount I/R control microprocessor. Once temperature and mode selections have been made, they are stored in the microprocessor memory when the unit is switched off. Next time unit is switched back on using the On/Off switch, stored settings are used and unit resumes operation.

Refer to the specific model of Air Handler for more detailed installation instructions.

After starting the unit, complete Test Unit Performance Data sheet on page 17.

Save this information for future servicing. In event there is a problem with the unit.

Perform the test again (if possible) and have both sets of data ready when calling for assistance.

Figure 5

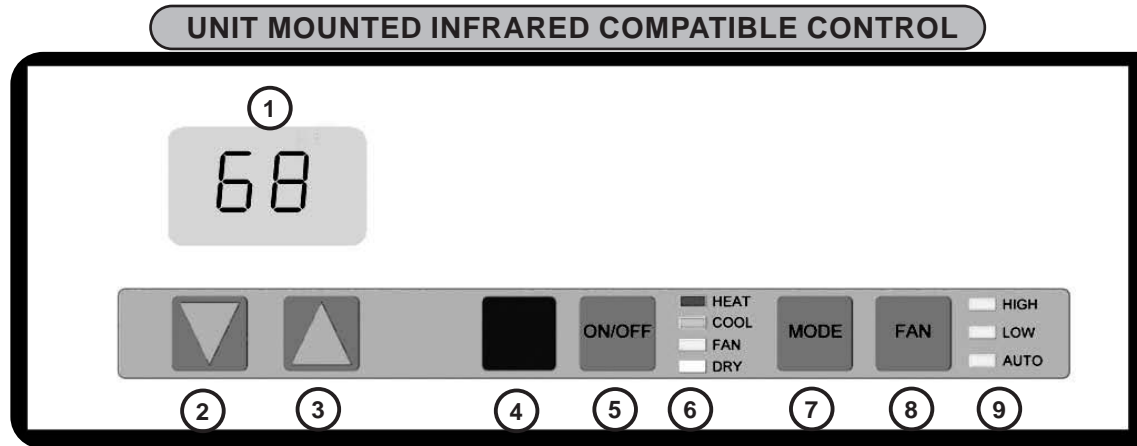

- | | | |
|--------------------------------|---|---|
| 1. LCD Display | 4. Infrared Sensor | 7. Mode Selection Button |
| 2. Temp. Set Point Down Button | 5. Power ON/OFF Button | 8. Fan Operation Button |
| 3. Temp. Set Point Up Button | 6. Mode Indicator LEDs (HEAT, COOL, FAN, DRY) | 9. Fan Indicator LEDs (HIGH, LOW, AUTO) |

On/Off Switch

On/Off switch is used to turn equipment on or off. In **off** mode display will be blank and all LED indicator lights will be dark. To turn unit on press **On/off** button once. Room temperature will be displayed and amber LED indicators will show fan speed and mode selections (Figure 5).

Mode Switch (System Switch)

Mode button allows for selection of desired mode of operation. Colored LED indicators light next to selected mode. With each successive press of **Mode** button, selection rotates between **Heat, Cool, Fan or Dry** mode. If dipswitches are set for cooling only (off – off) **Heat** and **Dry** are not accessible (Figure 5).

Fan Operation

Indoor unit utilizes two-speed motor with three operational fan modes. Fan button allows selection of desired fan setting. Amber LED indicator lights next to fan speed selection. If **Auto** fan mode is selected then LED indicator also lights next to Auto.

High and **Low** are constant fan settings. Fan will operate continuous regardless of set point or room temperatures. **Auto** mode is cycling fan setting.

Auto fan mode can only be selected if unit is in **Heat** or **Cool** mode. In **Auto** mode fan cycles with call for Heat or Cool. Fan speed is determined by microprocessor and speed adjustment is made according to room and setpoint temperatures. Fan will switch to **High** speed when room temperature deviates by more than two degrees from setpoint. Fan will switch to low speed if deviation is one degree. When room temperature reaches setpoint temperature heat/cool call will then be dropped. Fan will stay on for additional 60 sec. to purge unit of any residual energy. After fan has been off for ten minutes, fan will cycle on for 60 seconds. This is done so microprocessor can sample room air and also help eliminate room temperature stratification.

When unit is in **Dry** mode fan speed remains constant at **low** speed. While unit is in **Fan** mode, **Auto** is bypassed and only **High** or **Low** are available (Figure 5).

Cooling Only Operation

For cooling operation, turn unit on via On/off button. Select Cool mode via Mode button. Room temperature is displayed. By pressing either Up or Down arrow once, setpoint temperature appears. Setpoint temperature can be changed with each successive press of Up or Down arrow buttons or by holding button in. Place setpoint temperature below room temperature.

Optional Electric heat operation

Important: The dip switch 1 & 2 must be set to ON

For electric heat operation turn unit on via **On/Off** button. Select **Heat** mode via **Mode** button. Room temperature will be displayed. Then press either **Up** or **Down** arrow once, setpoint temperature will appear. Setpoint temperature can then be changed with each successive press of **Up** or **Down** arrow or by holding button in. Place setpoint temperature above room temperature. Electric heat will energize and heating will continue as long as setpoint remains above room temperature. Once room temperature is satisfied electric heat cycles off. Fan will operate as described in "Fan Operation" (Figure 5).

Dry Mode Operation

Dry mode removes humidity from air while maintaining specific setpoint temperature. This is done in cooling along with electric or hydronic heater. Dry mode will not maintain specific humidity level. Unit must be equipped with optional electric heat element or hydronic coil.

For Dry Mode operation turn unit on via On/off button. Select Dry mode via Mode button. Room temperature is displayed. Then press either Up or Down arrow once, setpoint temperature will appear. Setpoint temperature can then be changed with each successive press of Up or Down arrow or by holding button in.

Place setpoint temperature at desired room temperature. Depending on difference between room temperature and set point temperature cooling and/or heating will energize. If room temperature and setpoint temperature are the same unit will operate in cooling and electric heat source will also energize.

Should room temperature fall below setpoint temperature by two degrees, cooling stops and heating continues to boost room temperature back up to stepoint temperature. If room temperature rises above setpoint temperature by two degrees, heating will stop and cooling will continue to bring room temperature back down to stepoint temperature. Fan will operate continuously at low speed while in Dry Mode.

Units With Condensate Pumps

EMI Air Handlers are available with optional condensate pump. Condensate pumps are recommended when it is not possible to gravity drain condensate from indoor unit. Depending on pump manufacture maximum lift for pump will vary. Consult pump instructions for maximum lift for pump being used or refer to specific pump kit information and instructions as supplied by EMI.

Condensate generated by the evaporator will collect in pumps' reservoir. When water level is high enough, float switch closes and energizes pump motor clearing water from the reservoir. Should the water exceed maximum preset level, safety switch will open. This prevents evaporator from generating more condensate and spilling out of the unit.

Figure 6

INFRARED REMOTE CONTROL OPTION
OPERATIONAL RANGE 55- 90° F (IN 1° INCREMENTS.)

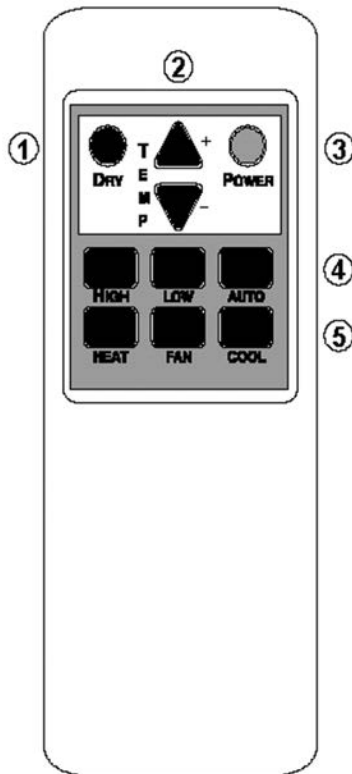

1. Dry Mode Button
2. Temp. Set Point UP/DOWN Button
3. Power ON/OFF Button
4. Fan Speed Button (HIGH, LOW, AUTO)
5. Operational Mode Buttons (HEAT, FAN, COOL)

NOTE: Batteries Included.

High-Wall Thermostat Control Start-Up

Choosing a Thermostat

EMI offers several remote thermostats compatible with air handlers. Choose a thermostat that matches the equipment you have selected. For single stage cooling or heating choose single stage Heat/Cool thermostat. When selecting a thermostat other than those offered by EMI, choose a 24V thermostat that matches your application. EMI equipment is compatible with most mercury bulb, digital or power stealing thermostats.

Cooling Only With Electric Heat Or Hydronic Heat

Select a thermostat compatible with cooling - electric heat system. Thermostat should have "R", "Y", "W" and "G" terminals. Thermostat may also have "C" terminal.

Fan Operation

Some thermostats are equipped with **auto/on** fan switch. When this switch is placed in **on** position indoor fan will run continuous. When switch is in **auto** position indoor fan cycles with call for heating or cooling.

Fan Purge

Indoor unit is equipped electronic circuit board with purge feature. After room thermostat has been satisfied, purge feature allows indoor fan to remain on for additional 60 seconds. This increases efficiency by pulling remaining energy from unit.

Cooling Operation

Electronic circuit board of indoor unit also has an anti-short cycle timer (ASCT) feature designed to prevent short cycling. Once room temperature is satisfied and unit switches off, ASCT will not allow unit to restart until three-minute time period has elapsed.

After connecting thermostat to unit place system switch in **cool** mode. Adjust set-point temperature below room temperature. For chilled water systems, coldwater valve opens allowing flow of water. Place set-point temperature above room temperature. CW valve closes while indoor fan remains on for additional sixty seconds.

Electric Heat Operation

Place thermostat system switch in **heat mode**. Adjust set-point temperature above room temperature. Electric heat energizes with the indoor fan motor. Heating continues so long as set-point remains above room temperature. Place set-point temperature below room temperature. Electric heater switches off and indoor fan remains on for additional sixty seconds.

Hydronic Heat Operation (Optional On CCP Units)

Optional hydronic heat package may be selected in lieu of electric heat. Heating operation is essentially same as units with electric heat. With thermostat **system switch** set to **heat** and set-point temperature above room temperature, hydronic valve opens allowing water to flow through coil. Indoor fan switches on and warm air will flow from unit. Heating will continue so long as set-point remains above room temperature. Place set-point temperature below room temperature. Hydronic valve will close and indoor fan switches off after sixty-second purge time has elapsed. Units with optional hydronic heat coil or chilled water coil are also equipped with freeze protection thermostat. Freeze protection thermostat is designed to protect hydronic coil or chilled water coil from freeze up due to abnormally cold fresh air from fresh air system. Should freeze sensor activate, indoor fan switches off to eliminate source of cold fresh air. For units with hydronic hot water valve installed, valve will be energized allowing warm water to flow and assist in defrost process. System remains in this state until freeze condition is satisfied where-by freeze thermostat will reset.

After starting unit, complete Test Unit Performance Data sheet on page 17.

Save this information for future servicing. In event there is a problem with the unit.

Perform test again (if possible) and have both sets of data ready when calling for assistance.

START-UP, MAINTENANCE AND TROUBLESHOOTING PROCEDURE

Test Unit Performance Data sheet below is provided for use by qualified service professional. In order for our Technical Service Department to better serve you, please complete and have this information ready when calling.

Make sure to include the Model Number, Serial Number, Date of Installation.

Call Technical Support Department
@ 1-800-253-7900.

Test Unit Performance Data	
	Date:
Model Number	Technician:
Serial Number	Mode: Cooling
Indoor Section	Notes
Evaporator Entering Air - DB	
Evaporator Entering Air - WB	
Evaporator Leaving Air - DB	
Evaporator Leaving Air - WB	
Outdoor Section	
Entering Air	
Leaving Air	
Temperature Split	
Operating Pressures	
Compressor Suction - PSIG	
Compressor Discharge - PSIG	
Power Input	
Compressor - Volts	
Compressor - Amps	
OD Fan Motor - Volts	
OD Fan Motor - Amps	
ID Fan Motor - Volts	
ID Fan Motor - Amps	
Total Volts	
Total Amps	
Temperatures - Degrees F°	
Compressor Suction	
Compressor Discharge	
Liquid Out Cond.	
Liquid before Expansion	
Suction out Evaporator	
Capacity Calculations	
DB - Temp Split at evap.	
Test Summary	
Compressor Superheat	
Sub Cooling	

MAINTENANCE AND TROUBLESHOOTING PROCEDURE

For Emi Air Handlers With Unit Mount Infrared Controls

Maintenance

Have service and annual maintenance performed by a qualified service agency. EMI units are designed and constructed for reliability and long life with minimal maintenance. To insure peak operating efficiency:

1. Clean air filters on monthly basis: Filter is accessed by removing air intake access panel.
2. Clean with vacuum cleaner that has brush attachment or use garden hose. Allowing dust to collect on filter will cause unit to lose efficiency and eventually malfunction.
3. Vacuum dust from return air grille and coil surface when cleaning filter.

Troubleshooting

⚠ WARNING

All service should be performed by a qualified service technician. Before removing access panels or control covers to expose moving parts of non-insulated live electrical components for service, disconnect all high volt power supplies to both the indoor unit and outdoor unit. Failure to do so could result in physical injury and/or electrical shock.

When troubleshooting indoor unit, refer to wiring diagram supplied with equipment. May be found on on back of removable return air grill (WCP) or on back of access panel (CCP). Please have model and serial number available when calling.

Number of low volt interconnect conductors is three to six depending on heating options and or thermostat selection. Interconnect wire should be at least 18 AWG. Refer to unit wiring diagram for interconnect diagram that matches your system.

Figure 1A

CCP U/M COOLING/HYDRONIC HEAT

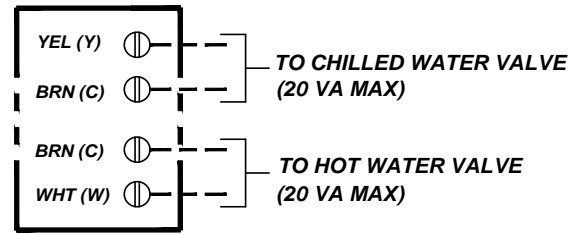

**NEC CLASS 2
LOW VOLTAGE
INTERCONNECT DIAGRAM**

Figure 2

CCP RMT HYDRONIC HEAT

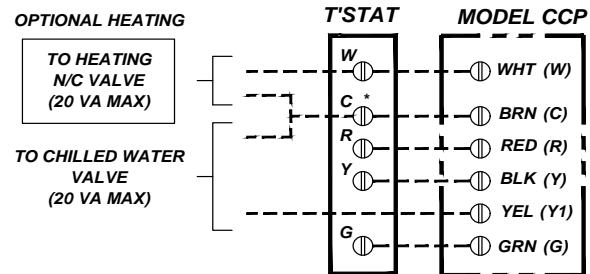

**NEC CLASS 2
LOW VOLTAGE CONNECTIONS
*SOME T*STATS MAY NOT
HAVE A "C" TERMINAL**

Figure 2 A

CCP/WCP RMT ELECTRIC HEAT

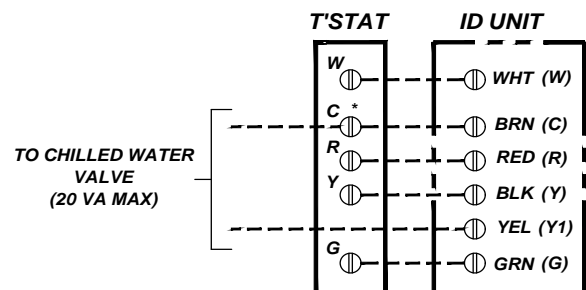

**NEC CLASS 2
LOW VOLTAGE CONNECTIONS
*SOME T*STATS MAY NOT
HAVE A "C" TERMINAL**

Figure 1

CCP/WCP UNIT MOUNT CONTROL

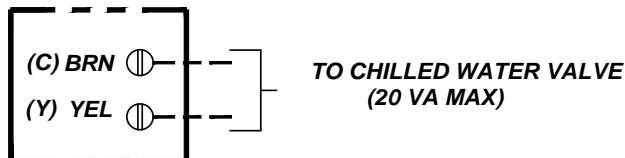

**NEC CLASS 2
LOW VOLTAGE
INTERCONNECT DIAGRAM**

Power Supply Check

- Verify proper field voltage and breaker size with rating plate.
- Use voltmeter to verify incoming power supply agrees with rating plate. Incoming power should not exceed nameplate voltage. Incoming power should not be below minimum voltage stated on rating plate (197V for units rated 208/230V and 104V for units rated 115V).
- Check low voltage power. Place voltmeter across low Volt terminals "R" and "C" at indoor unit, reading should be 24V.

Test Mode

Test mode is available only on units with unit mounted controls. Test mode feature aids in functional check of the unit. Use to help isolate a problem source.

NOTICE

While in test mode, all timers are eliminated. After system checks are complete, control shall be returned to normal operation. **DO NOT LEAVE SYSTEM IN TEST MODE!**

To enter test mode place unit in **off state**.

Use unit mounted keypad. Depress both **up** and **down** arrow buttons simultaneously and push **On/Off** button in for one second. Unit is now in test mode. System function checks can now be made without having to wait for timer delays.

To return to normal operation, switch unit off again via **On/Off** button for at least 30 seconds. When system is switched back on, normal operation will resume.

Cooling Only Units

Cooling only units utilize **low Volt** interconnecting wires between indoor unit and thermostat.

Air handlers with unit mounted controls, wires (WCP) or terminals (CCP) designated "Y" (yellow) and "C" (brown) of indoor air handler should be connected to corresponding "Y" (yellow) and "C" (brown) wires or terminals.

Other wires or terminals such as "R"(red) or "O" (orange) may not be needed. Protect unused terminals by use of wire nut from making contact with junction box or other metal surfaces.

Refer to low volt interconnect diagram interconnect diagram **Figure 1** for unit mounted controls and **Figure 2** for remote thermostat connection.

24V transformer located in indoor air handler unit provides low Volt control power to indoor air handler.

24V power supply can be measured by placing meter across "R" and "C" low Volt terminals. Air handler will switch on and off cooling through yellow (Y) wire. When air handler is calling for cooling, 24V can be measured between terminals (wires) Y and C.

Electric Heat

Units with electric heat utilize control relay located on circuit board in control box. As safety feature, auto reset limit switch located on heater end plate or on heater assembly interrupts power to the heater should an over-heat condition occur.

Each electric heat assembly is also equipped with a one time fuse link. Should electric heat temperatures rise above auto reset limit switch, a non-reset, one time fuse link will open and heater will remain off.

Following current values apply when unit is connected to 230V power supply. These values include fan motor current. If supply power is different, amp draw of heater is affected.

5kW = 22.3 Amps
4kW = 18 Amps
3kW = 13.5 Amps

Units With Optional Condensate Pumps

EMI Air Handlers are available with optional condensate pump. Condensate pumps are recommended when it is not possible to gravity drain condensate from indoor unit. Depending on pump manufacture the maximum lift for pump will vary. Consult pump instructions for maximum lift for pump being used.

Condensate generated by air handler will collect in pumps' reservoir. When water level is high enough, float switch closes and energizes pump motor clearing water from the reservoir. Should water exceed maximum preset level, safety switch will open, interrupting (Y) signal. This prevents air handler from generating more condensate and spilling out of unit.

Error Codes

Should one of two temperature sensors become disconnected or fail, error code will appear in display. Control will not operate properly until sensor is working.

E1 – Coil Sensor malfunction or disconnected.

Check location **J1** on thermostat board.

E2 – Room Air Sensor malfunction or disconnected.

Check location **J2** on thermostat board.

Q: Display on indoor unit is blank. What should I do?

A: Check power supply (see "Power supply check" Section).

If unit still fails to operate via **On/off** button inspect control box for loose wire. Also inspect circuit boards for burnt components. If no obvious problem can be found replace all circuit boards including unit keypad. Do not attempt to troubleshoot individual circuit boards.

Q: Display flicker. Is this normal?

A: Small amount of flickering of display is normal. Room lighting may make flickering more noticeable at times.

Q: How long will fan run?

A: While unit is in cooling or heating and auto fan mode is selected, fan speed is determined by the microprocessor and speed adjustment is made according to room and setpoint temperatures. Fan will switch to **High** speed when room temperature deviates by more than two degrees from setpoint. Fan will switch to **Low** speed if deviation is one degree. When room temperature reaches setpoint temperature heat/cool call is dropped. Fan will stay on for additional 60 sec. to purge unit of any residual energy. If **High** or **Low** is selected fan will operate continuously regardless of set point or room temperatures.

Q: What causes my indoor unit to freeze-up?

A: Evaporator freeze up is usually symptom of another problem. Units with infrared compatible, unit mounted controls are equipped with freeze protection to prevent freeze up from occurring. If freeze up does occur check the following.

- Check freeze sensor is located in lowest part of coil. Generally this is where freeze up will begin.
- Check freeze sensor is inserted fully and snugly in coil fin. If not, another location may need to be selected. Be careful not to insert sensor directly into coil tube rather insert sensor between two tubes.
- Check indoor air filter. It should be clean and free of dirt. Dirty filter reduces airflow and efficiency. Verify coil is clean. If coil is dirty then it should be cleaned using an appropriate coil cleaner or mild detergent.

WARRANTY

EMI (COMFORTWAVE CHILLED WATER, ENVIROAIR PTAC) RETROAIRE (PTAC, VPRC/H, RQTH, WATER SOURCE HEAT PUMP CONSOLES) LIMITED WARRANTY

Effective Date September 1, 2017

THIS LIMITED WARRANTY GIVES THE ORIGINAL PURCHASER ONLY SPECIFIC LEGAL RIGHTS AND YOU MAY ALSO HAVE OTHER LEGAL RIGHTS WHICH VARY FROM STATE-TO-STATE AND PROVINCE-TO-PROVINCE

Keep this warranty certificate and the installation manual supplied with your unit for future reference.

Our Warranty

By this warranty statement ("Limited Warranty"), ECR International, Inc. ("ECR") issues limited warranties from the date of installation of the applicable EMI Product ("Product") to the Original Purchaser (as defined herein), subject to the terms and conditions stated below. As used in this Limited Warranty "Original Purchaser" shall mean, the end-user that purchased the new Product directly (a) from the EMI brand dealer; or (b) in the case of a newly constructed home, from the contractor who purchased such new Product directly from an EMI brand dealer or wholesaler for installation and use in the newly constructed home.

EMI/RETROAIRE COMMERCIAL AND RESIDENTIAL LIMITED WARRANTY

The following limited warranty shall apply to only the Original Purchaser, at original installation site, of the EMI/Retroaire Product, used without interruption by the Original Purchaser.

ECR warrants its Product used in commercial and residential applications to be free from defects in material and workmanship under normal usage for a period of one (1) year from the date of original installation. In the event that any part of such product is found to be defective in material or workmanship during this one-year period, then ECR will repair or replace, at its option, the defective part. Labor charges to diagnose, troubleshoot, remove and install repaired or replaced parts are the responsibility of the Original Purchaser along with any freight charges.

Unit Compressors of such Product shall be free from defects in materials and workmanship under normal usage and maintenance for a period of five (5) years from the date of original installation. In the event that the Unit Compressor is found to be defective in material or workmanship during this period, then ECR will repair or replace, at its option, the defective part. Labor charges to diagnose, troubleshoot, remove and install repaired or replaced parts are the responsibility of the Original Purchaser along with any freight charges.

.....

LIMITATIONS/EXCLUSIONS – APPLIES TO ALL WARRANTIES

1. ECR will under no circumstances be responsible for and does not warrant damages or costs due to or arising from misapplication or misuse, improper installation or service,

components not supplied or approved by ECR, including, without limitation, indoor and outdoor units supplied by others, installation and normal maintenance such as, but not limited to, replacing air filters, cleaning, air flow adjustments, Products manufactured or distributed by ECR but installed outside the United States and Canada, damages from unauthorized alteration, application or improper operation, the failure of external wiring or other attachments and accessory products not integral to the Product or the use of parts not supplied or designated by ECR, damages or repairs as a consequence of shipping or handling, damages caused by faulty or interrupted power supply or electrical service, or damages caused by acts of God including, but not limited to, wind, hail, floods, lightning, earthquakes or other conditions beyond the control of ECR.

2. For all sales not subject to the Magnuson-Moss Warranty Act, there are no implied warranties of merchantability or fitness for a particular purpose, all of which are hereby specifically disclaimed. For all other sales, all implied warranties of merchantability and/or fitness for any particular purpose are limited in duration to the period of this Limited Warranty. The rights and remedies provided herein are exclusive and constitute the entire contract. This limited warranty and any optional extended warranties are granted only to the Original Purchaser and become null and void if payment for the goods or product is in default. This Limited Warranty is not transferable.

3. This Limited Warranty in no way can be considered as a guarantee of workmanship of an installer or repairman connected with the installation or service of the Product or as imposing on ECR liability of any nature for unsatisfactory performance as a result of faulty workmanship in the installation or service of the Product, which liability is expressly disclaimed.

4. ECR EXPRESSLY DISCLAIMS, AND IN NO EVENT SHALL ECR BE LIABLE (WHETHER FOR BREACH OF THIS LIMITED WARRANTY OR CONTRACT, FOR STRICT LIABILITY FOR NEGLIGENCE, OR OTHERWISE), FOR ANY SPECIAL, INCIDENTAL, PUNITIVE OR CONSEQUENTIAL DAMAGES, INCLUDING, WITHOUT LIMITATION, DAMAGES FOR LOSS OF PROFITS, LOSS OF GOODWILL, LOSS OF TIME OR CONVENIENCE, LOSS OF USE OF THE PRODUCT, THE COST OF A PRODUCT

WARRANTY

EMI (COMFORTWAVE CHILLED WATER, ENVIROAIR PTAC) RETROAIRE (PTAC, VPRC/H, RQTH, WATER SOURCE HEAT PUMP CONSOLES)

LIMITED WARRANTY

Effective Date September 1, 2017

THIS LIMITED WARRANTY GIVES THE ORIGINAL PURCHASER ONLY SPECIFIC LEGAL RIGHTS AND YOU MAY ALSO HAVE OTHER LEGAL RIGHTS WHICH VARY FROM STATE-TO-STATE AND PROVINCE-TO-PROVINCE

Keep this warranty certificate and the installation manual supplied with your unit for future reference.

RENTAL, COSTS OF GASOLINE, ELECTRICITY, TELEPHONE, TRAVEL OR LODGING, OR THE LOSS OF PERSONAL OR COMMERCIAL PROPERTY, WHETHER OR NOT ECR HAS BEEN ADVISED OF THE POSSIBILITY OF ANY SUCH DAMAGES.

PLEASE NOTE: Some states do not allow the exclusion or limitation of incidental or consequential damages, or limitations on how long an implied warranty lasts, so the above limitations and exclusions may not apply to you.

5. In no event shall ECR's obligations under this Limited Warranty exceed the purchase price of the Product. Any repairs or replacement performed under this limited warranty will apply to the original warranty period only and shall not in any way extend the statute of limitations for claims under this Limited Warranty.

MISCELLANEOUS

The Magnuson-Moss Warranty Act applies to "consumer" sales as contrasted with "commercial" sales. A consumer sale is one to a buyer for personal, family or household purposes and not for the purpose of resale.

By "implied warranties" we mean ones the law presumes to have been given by the seller even though they are not set out in writing.

"Fitness for a particular purpose" means the seller knows the particular purpose for which the buyer requires the goods, and the buyer relies on the seller's skill and judgment in making the purchase.

"Merchantable" means that the product is fit for the ordinary purposes for which that kind of product is used.

"Incidental" damages include expenses of inspection, obtaining substitute goods, transportation, etc.

"Consequential" damages include injury to persons or property resulting from a breach of warranty, and any loss from general or particular requirements known to us and which you cannot reasonably prevent.

If any provision of this Limited Warranty shall be determined to be illegal, unconscionable or unenforceable, all other terms and provisions hereof shall nevertheless remain effective and shall be enforced to the fullest extent permitted by law. The warranties made under this Limited Warranty are exclusive and may not be altered, enlarged or changed by a distributor, dealer, or other person whatsoever.

PROCEDURE FOR OBTAINING WARRANTY SERVICE

For prompt warranty service, notify the installer who, in turn, will notify the EMI distributor from whom such installer purchased the Product. If this action does not result in warranty service, the Original Purchaser or installer should contact ECR Customer Service (see contact information below), giving full particulars in support of the claim. Alleged defective part(s) must be returned through trade channels in accordance with ECR's procedure currently in force for handling returned goods for the purpose of inspection or determining the cause of failure. ECR will furnish the new part(s) to an authorized EMI distributor who, in turn, will furnish the part(s) to the contractor who installed the Product.

ECR International, Inc.

2201 Dwyer Ave. • P.O. Box 4729 • Utica, New York

13504-4729 Ph: 315/797-1310

Customer Service Fax: 315/724-9319

E-Mail: info@ecrinternational.com

Web: www.ecrinternational.com

PN 240000278, Rev C



2201 Dwyer Avenue, Utica, NY 13501

Tel. 800 253 7900

www.ecrinternational.com

All specifications subject to change without notice.

©2020 ECR International, Inc.