

INSTALLATION, OPERATION, AND MAINTENANCE MANUAL

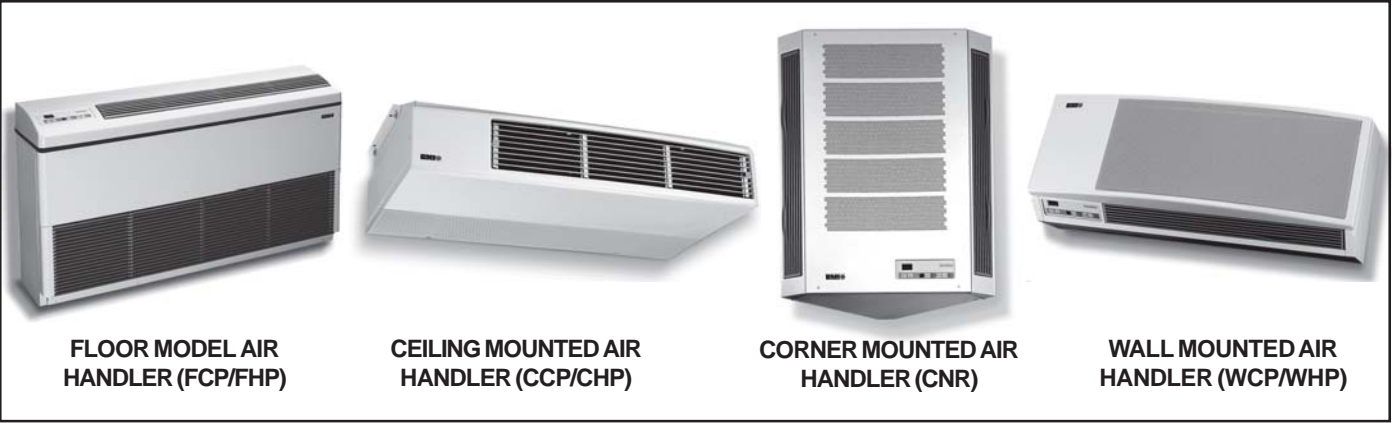

This manual is intended as an aid to qualified service personnel for proper installation, operation, and maintenance of the EMI ductless split system floor, wall, corner, or ceiling mounted air handler. Read these instructions thoroughly and carefully before attempting installation or operation. Failure to follow these instructions may result in improper installation, operation, service or maintenance, possibly resulting in fire, electrical shock, property damage, personal injury, or death.

TO THE INSTALLER

- (1) Retain this manual and warranty for future reference.
- (2) Before leaving the premises, review this manual to be sure the unit has been installed correctly and run the unit for one complete cycle to make sure it functions properly.

To obtain technical service or warranty assistance during or after the installation of this unit, call toll free:

1 – 800 – 228 – 9364

When calling for assistance, please have the following information ready:

- Model number _____
- Serial number _____
- Date of installation _____

⚠ RECOGNIZE THIS SYMBOL AS AN INDICATION OF IMPORTANT SAFETY INFORMATION. ⚠

TABLE OF CONTENTS

<u>Common To All Air Handlers</u>	
Safety Instructions	2
Installer Responsibilities	2
The EMI Air Handler Family	2
Installer Supplied Items	3
Materials of Construction	3
Inspection	3
Items for Consideration	3
Controls and Components	3
Unit Mount Infrared Control Operation	3
Optional Controls/Components	3
Electrical Wiring	4
Final Installation Checks and Start-up	4-5
Cooling Only Operation and Heat Operation	6-7
Remote Thermostat Operation	8-9
Floor Model Air Handler (FCP/FHP)	10-14
Ceiling Mounted Air Handler (CCP/CHP)	15-16
Corner Mounted Air Handler (CNR)	17-19
Wall Mounted Air Handler (WCP/WHP)	20-22
Maintenance and Troubleshooting	23-26
Test Unit Performance Data	27
Warranty	28

Specific Unit Installation

COMMON TO ALL AIR HANDLERS

SAFETY INSTRUCTIONS



Read all instructions before using the EMI Air Handler. Install or locate this unit only in accordance with these instructions. Use this unit only for its intended purpose as described in this manual.

- Check the rating plate on the EMI Air Handler before installation to make certain the voltage shown is the same as the electrical supply to the unit.
- The EMI Air Handler must be connected to a properly grounded electrical supply. Do not fail to properly ground this unit.
- Turn off the electrical supply before servicing the EMI Air Handler.
- Do not use the EMI Air Handler if it has damaged wiring, is not working properly, or has been damaged or dropped.

[Save these instructions]

INSTALLER RESPONSIBILITIES

This manual has been prepared to acquaint you with the installation, operation, and maintenance of this EMI Air Handler and to provide important safety information in these areas.

We urge you to read all of the instructions thoroughly before attempting the installation or operation of this unit. This manual should be kept for future reference.

The manufacturer of this unit will not be liable for any damages caused by failure to comply with the installation and operating instructions outlined in this manual.

A rating plate identifying this EMI Air Handler can be found on the unit. When referring to your unit, always have the information listed on the rating plate readily available.



Completely read all instructions prior to assembling, installing, operating, or repairing this product. Inspect all parts for damage prior to installation and start-up. The EMI Air Handler must be installed only by qualified installation personnel.

THE EMI AIR HANDLER FAMILY

The EMI Air Handler is available as a Dx direct expansion straight cool, heat pump – floor, wall, or ceiling units – and two-pipe chilled water fan coil model. The air handler offers ease of installation, operation, and service, and can be matched with EMI's SCC/SHC single-zone condensing unit or either of the company's multi-zone outdoor units, the MC2/MH2 or MC4/MH4. Presently, EMI does not offer a chiller unit that provides chilled water for the FCP, WCP and CCP models.

NOTE: Floor and ceiling units in 42,000 Btuh or 48,000 Btuh capacities must be matched with EMI's CCB/CHD condenser.

All EMI Air Handlers are subject to ongoing product development so designs and specifications may change without notice. For more information on a specific air handler, please refer to the corresponding section in this installation manual or, for information on EMI Condensing Units, please visit our website at www.enviromaster.com or contact the factory for the appropriate literature.

THE EMI DUCTLESS SPLIT SYSTEM AIR HANDLER FAMILY CONSISTS OF

- **FCP:** Two-pipe chilled water fan coil floor unit available in 9,000, 12,000, 18,000, 24,000, 30,000, 36,000, 42,000, and 48,000 nominal Btuh capacities.
- **FHP:** Dx straight cool/heat pump floor unit, available in 9,000, 12,000, 15,000, 18,000, 24,000, 30,000, 36,000, 42,000, and 48,000 nominal Btuh capacities.
- **WCP:** Two-pipe chilled water fan coil wall unit available in 9,000, 12,000, 15,000, 18,000, 24,000, and 30,000 nominal Btuh capacities.
- **WHP:** Dx straight cool/heat pump wall unit available in 9,000, 12,000, 15,000, 18,000, 24,000, 30,000, and 36,000 nominal Btuh capacities.
- **CNR:** Dx Straight cool/heat pump corner unit available in 9,000, and 12,000 nominal Btuh capacities.
- **CCP:** Two-pipe chilled water fan coil ceiling unit available in 9,000, 12,000, 18,000, 24,000, 30,000, 36,000, 42,000, and 48,000 nominal Btuh capacities.
- **CHP:** Dx Straight cool/heat pump floor unit available in 9,000, 12,000, 15,000, 18,000, 24,000, 30,000, 36,000, 42,000, and 48,000 nominal Btuh capacities.

All EMI Air Handlers are backed by Enviromaster International LLC and are tested and rated in accordance with ARI standards 210/240 and UL 1995.

INSTALLER SUPPLIED ITEMS

- Low voltage wiring (18 AWG required)
- Power wiring
- Mounting fasteners (screws, wall anchors, etc.)
- Chilled water, condensate, and refrigerant piping
- Refrigerant (for interconnect charge)

MATERIALS OF CONSTRUCTION

1. Cabinet fabricated of 20-gauge galvanized steel with an off-white powder coat matte finish
 - Plastic tops, fronts constructed of a high impact Polystyrene (HIPS) material
2. Discharge grill construction of high temperature Noryl plastic (WHP/WCP and CNR ONLY)
 - Anodized Aluminum discharge grill FHP/FCP & CHP/CCP
3. Condensate drain pan constructed of anticorrosive G90U galvanized steel

INSPECTION

Upon receipt of the shipment carefully check the shipment against the bill of lading. Make sure all the air handlers have been received. Inspect each unit for damage. Assure the carrier makes proper notation on the delivery receipt of all damage identified and that he completes a Carrier Inspection Report. Concealed damage must be reported to the carrier within 15 days of receipt of shipment.

IMPORTANT: *It is the responsibility of the purchaser to file all necessary claims with the carrier. Notify the Enviromaster International traffic department of all damages.*

ITEMS FOR CONSIDERATION

- Determine the best location for mounting the unit for room air circulation. Locate outdoor and indoor units as close together as possible.
- Determine how power wire (high and low voltage) condensate drainage, and refrigerant or water supply piping (for chilled water units) may be run to and from unit. Knockouts on the air handler may be used for this purpose.
- Determine if the air handler can be accessed for service without obstruction.
- **FHP, WHP, CNR, and CHP ONLY:** Ensure that interconnect tubing is within the maximum allowable length of 100' including a maximum 35' lift.
- Serviceability should be considered when locating the unit. The cabinet service panels must be able to be removed without obstruction.

CONTROLS AND COMPONENTS

Factory Installed or Supplied

- Unit mount control panel - standard on FHP/FCP, WHP/WCP and CNR (optional on CCP/CHP)
 - ¾" backlit LCD display
 - Adjustable operational range from 55° F to 95° F (in one-degree increments)
 - Anti-short cycle compressor protection
 - Minimum compressor run time
 - 60 second fan purge
 - Freeze protection
 - Audio feedback on control setting changes
 - Universal control board for straight cool or heat pump condenser operation
 - Two-stage heating w/optional electric heat and heat pump condenser
 - Fan operation: Auto (cycling), High and Low (constant)
 - Dry Mode (operates cooling and electric heat simultaneously to remove humidity when optional electric heat is selected)
 - Test Operation for ease of testing after installation (all timers eliminated)
 - Non-volatile Backup Memory (control settings maintained indefinitely during power outages)

IMPORTANT: *Unit mounted controls are fully functional without the hand-held remote. See page 6*

UNIT MOUNT INFRARED CONTROL OPERATION

EMI Air Handlers are equipped with a unit mount, infrared compatible control package, optional on the CCP/CHP. This user friendly, microprocessor control is designed to optimize system performance and protect the refrigeration system from unwanted short cycling and evaporator freeze-ups. Operation of the unit can be made by either the keypad on the unit or by using the optional hand held infrared controller.

OPTIONAL CONTROLS/COMPONENTS

- Infrared thermostat with hand held remote for CCP/CHP
- Condensate Pump (field or factory installed)
- Chilled Water Control Valve (field installed)
- Wiring for normally closed/power open valve (24V AC, 20VA max. or 8VA max. on units with condensate pumps)
- Open wire electric heaters in all size (all with automatic reset high temperature cutout and redundant high temperature fuse link)
- Hydronic heat coil with sweat connections (consult factory) FCP/FHP and CCP/CHP only.

ELECTRICAL WIRING

(SEE THE APPROPRIATE AIR HANDLER SECTION FOR SPECIFIC WIRING INFORMATION.)

All wiring should be in accordance with the National Electric Code (NEC) and the local building codes.

1. Inspect the existing wiring for any deficiencies such as cut or frayed wires. Replace such wiring if found.
2. Check the unit rating plate for circuit ampacity and breaker or fuse size. **Use only HACR type breakers.** Select the proper wire for the ampacity rating.
3. Each unit must have a separate branch circuit protected by a fuse or breaker. Refer to the unit rating plate for the proper wire and breaker or fuse size.
4. Connect the power wire to Black (L1) and the other wire to Red/White (L2) at the power connector location. Connect the ground wire to the ground lug lead at the same location in the control box.
5. Low voltage wiring must be run to the outdoor unit and thermostat. Refer to the Wiring Diagram on the unit for details. Be sure to use at least 18 AWG wire. (Figures 1, 2 or 3)

Figure 1

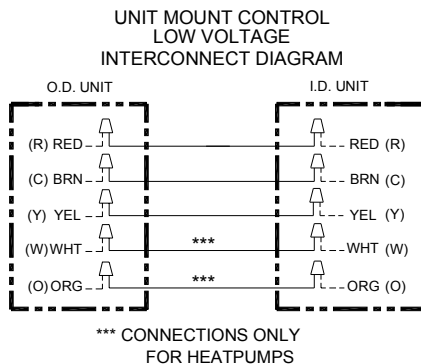

Figure 2

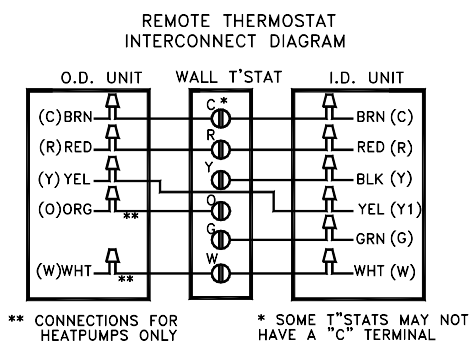
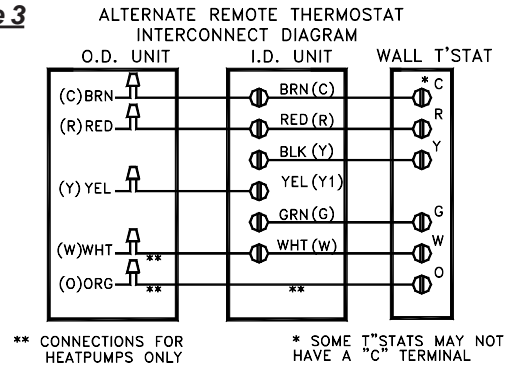

Figure 3



EMI indoor units do not contain a low volt transformer. Low volt power is supplied by a transformer located in the condenser. If using a condenser made by other manufacturers, a low volt 40VA transformer needs to be supplied by the installer.

NOTE: On units rated 208/230V, the primary side of the transformer is factory wired for 230V. For a 208V power supply, the transformer tap must be changed from orange to red.

IMPORTANT: When wiring the WHP 18-36 only: If the job site voltage is 208V, the WHP high-low fan speed switch must be rewired. Replace the black and red fan motor wire connections with the blue and orange fan motor wires respectively.

See unit wire diagram for specific details.

INITIAL START-UP Unit Mount Controls Only

The unit will start in time delay (unit mount controls only). These are the default settings of the unit mount I/R control microprocessor. Once temperature and mode selections have been made, they will be stored in the microprocessor memory when the unit is switched off. The next time the unit is switched back on via the *On/Off* switch, the stored settings will be used and the unit will resume operation.

FINAL INSTALLATION CHECKS

The unit filter must be in place and able to be removed easily for maintenance. To avoid vibration, check refrigerant lines/chilled water lines to ensure they are not in contact with each other. The unit(s) must be mounted securely and level.

COMMON TO ALL AIR HANDLERS *Continued*

START UP

See the “Common” section of this manual (pages 2-8) for control details.

- Be sure the filter is in place, the unit is level and separate any lines that contact each other, before replacing the cabinet front onto the chassis.

Test each power and circuit connection before powering up the system. Use the unit mounted electronic thermostat controls to start the system. (See previous pages 3-8 for operating instructions on Control Operation Section, Thermostat, unit mount or remote.)

NOTE: Check the outdoor unit’s start-up instructions for specific requirements and procedures.

Operation of the unit depends on the room temperature. It may be necessary to warm the room before testing the unit’s cooling abilities.

Refer to the *specific model of Air Handler* for more detailed installation instructions. (Pages 10-22)

DIP SWITCH SETTINGS

There are two dipswitches on the relay board that offer different modes of operation. This allows the unit to be matched with either a cooling only or heat pump condenser. Dipswitches are factory set for a cooling only condenser. If the indoor unit is matched with an EMI single zone or multi-zone heat pump condenser then, the dipswitches will need to be changed.



WARNING

Before accessing the control compartment, disconnect power to both the indoor and outdoor units. Failure to do so could result in serious injury or electrical shock. DO NOT change dipswitch settings with power applied to the unit.

To gain access to the relay board, first remove the return air grill from the front of the unit. Then remove any panels or covers to the control section. The relay board is located in the control box of the unit. Set the dipswitches (Figure 4) according to the table below.

DIP SWITCH SETTINGS

Switch	1	2
Cooling only	Open	Open
Cooling Electric or Hydronic Heat	On	On
All Heat Pumps	Open	On

Off = Open

Once the dipswitches are set and all covers and panels are replaced, power can be applied to the equipment. When 24V power is applied, the microprocessor will read the dipswitch setting.

Figure 4



DIPSWITCH ON RELAY BOARD

ON/OFF SWITCH

The **On/Off** switch is used to turn the equipment on or off. In the **off** mode the display will be blank and all LED indicator lights will be dark. To turn on the unit press the **On/off** button once. Room temperature will be displayed and amber LED indicators will show fan speed and mode selections (Figure 5).

MODE SWITCH (System Switch)

The **Mode** button will allow the selection of the desired mode of operation. Colored LED indicators will light next to the selected mode. With each successive press of the **Mode** button, selection will rotate between **Heat, Cool, Fan or Dry** mode. If the dipswitches are set for cooling only (off – off) then **Heat** and **Dry** will not be accessible (Figure 5).

FAN OPERATION

The indoor unit utilizes a two-speed motor with three operational fan modes. The **Fan** button will allow the selection of the desired fan setting. An amber LED indicator will light next to the fan speed selection. If **Auto** fan mode is selected then an LED indicator will also light next to **Auto**.

High and **Low** are constant fan settings. The fan will operate continuous regardless of set point or room temperatures. **Auto** mode is a cycling fan setting.

Auto fan mode can only be selected if the unit is in **Heat** or **Cool** mode. In **Auto** mode the fan will cycle with the call for Heat or Cool. Fan speed will be determined by the microprocessor and speed adjustment will be made according to room and setpoint temperatures. The fan will switch to **High** speed when room temperature deviates by more than two degrees from setpoint. The fan will switch to low speed if the deviation is one degree. When the room temperature reaches setpoint temperature the heat/cool call will then be dropped. The fan will stay on for an additional 60 sec. to purge unit of any residual energy. After the fan

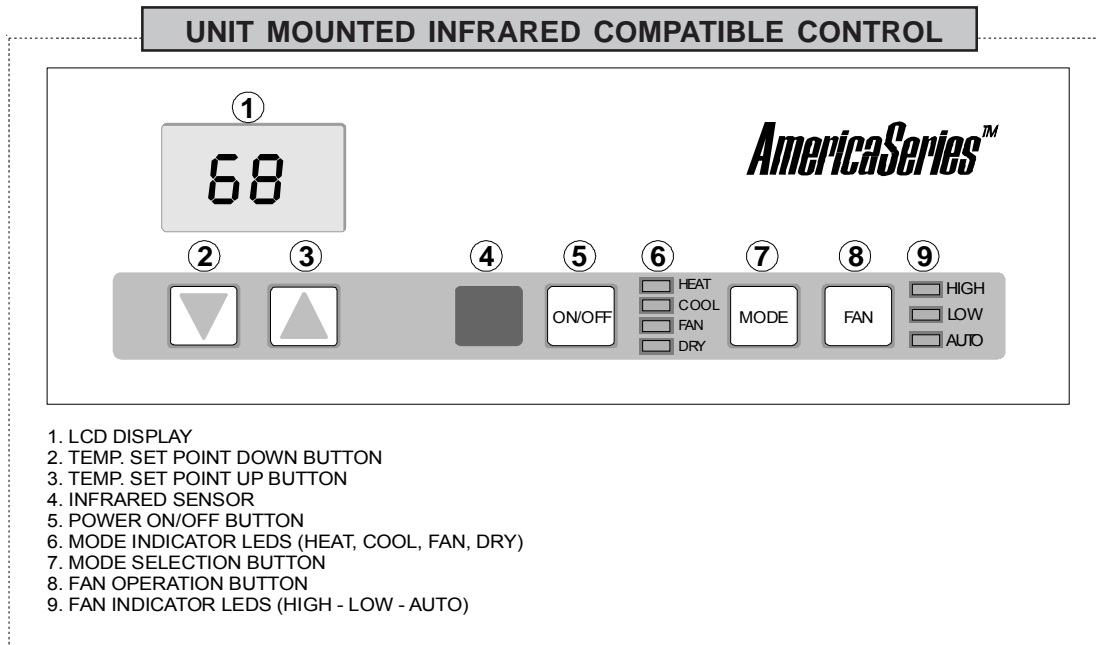

Figure 5

has been off for ten minutes, the fan will cycle on for 60 seconds. This is done so the microprocessor can sample the room air and also helps eliminate room temperature stratification.

When the unit is in **Dry** mode the fan speed will remain constant at **low** speed. While the unit is in **Fan** mode, **Auto** is bypassed and only **High** or **Low** are available (Figure 5).

Once the room temperature is satisfied and the two-minute minimum run time has elapsed the compressor will cycle off. The fan will operate as described in “Fan Operation” (Figure 5).

NOTE: Once the compressor is switched off there is a three-minute delay before it will re-start.

COOLING ONLY OPERATION

For cooling operation first turn the unit on via the **On/off** button. Select **Cool** mode via the **Mode** button. The room temperature will be displayed. Then, by depressing either the **Up** or **Down** arrow once, the setpoint temperature will appear. The setpoint temperature can then be changed with each successive press of the **Up** or **Down** arrow buttons or by holding the button in. Place the setpoint temperature below the room temperature. The compressor will start and cooling will continue for a minimum of two minutes and as long as the setpoint remains below room temperature. (*On initial startup or if power is lost, there is a three-minute delay between compressor re-starts.*)

OPTIONAL ELECTRIC HEAT OPERATION (Non Heat Pump Condenser Units Only)

For electric heat operation first turn the unit on via the **On/off** button. Select **Heat** mode via the **Mode** button. The room temperature will be displayed. Then by depressing either the **Up** or **Down** arrow once, the setpoint temperature will appear. The setpoint temperature can then be changed with each successive press of the **Up** or **Down** arrow or by holding the button in. Place the setpoint temperature above room temperature. The electric heat will energize and heating will continue as long as the setpoint remains above room temperature. Once the room temperature is satisfied the electric heat will cycle off. The fan will operate as described in “Fan Operation” (Figure 5).

OPTIONAL HEATPUMP WITH ELECTRIC HEAT (2-Stage Heating)

For heat pump operation with backup electric heat, first turn the unit on via the **On/off** button. Select **Heat** mode via the **Mode** button. The room temperature will be displayed. Then, by depressing either the **Up** or **Down** arrow once, the setpoint temperature will appear. The setpoint temperature can then be changed with each successive press of the **Up** or **Down** arrow or by holding the button in.

Place the setpoint temperature one-degree above the room temperature. The compressor will start and heating will continue for a minimum of two minutes and as long as the setpoint remains above room temperature. Once the room temperature is satisfied and the two-minute minimum run time has elapsed, the compressor will cycle off.

() On initial startup (or if power is lost) there is a three-minute delay between compressor re-starts.*

*(**) Some EMI Heat pump condensers are equipped with a low temperature cutout that will shut down the condenser and energize the indoor heat. This is designed to protect the compressor under certain outdoor conditions.*

Next, place the setpoint temperature at least two degrees above room temperature. The electric heat will energize along with the compressor (heatpump) thus two-stage heating. The electric heat will continue to run until the deviation between room temperature and setpoint temperature is less than two degrees. At that time the electric heat will switch off and the heatpump will take over the heating demand. Once the room temperature is satisfied and the two-minute minimum run time has elapsed, the compressor will cycle off. There is then a three-minute delay before the compressor can restart. The fan will operate as described in "Fan Operation" (Figure 5).

DRY MODE OPERATION

Dry mode will remove humidity from the air while maintaining a specific setpoint temperature. This is done by energizing the compressor in cooling along with the electric or hydronic heater. Dry mode **will not** maintain a specific humidity level. The unit must be equipped with an optional electric heat element or hydronic coil.

For Dry Mode operation first turn the unit on via the **On/off** button. Select **Dry** mode via the **Mode** button. The room temperature will be displayed. Then by depressing either the **Up** or **Down** arrow once, the setpoint temperature will appear. The setpoint temperature can then be changed with each successive press of the **Up** or **Down** arrow or by holding the button in.

Place the setpoint temperature at a desired room temperature. Depending on the difference between room temperature and set point temperature the compressor and/or heat source will energize. If the room temperature and setpoint temperature are the same the compressor will operate in cooling and the electric heat source will also energize.

Should the room temperature fall below the setpoint temperature by two degrees, the compressor will stop and heating will continue to boost the room temperature back up to setpoint temperature. If the room temperature rises above the setpoint temperature by two degrees, heating will stop and cooling will continue to bring the room temperature back down to setpoint temperature. The fan will operate continuously at low speed while in Dry Mode.

In order to prevent short cycling the minimum on time for both cooling and heating is two minutes. The minimum off time is 3 minutes (Figure 5).

UNITS WITH CONDENSATE PUMPS

EMI Air Handlers are available with an optional condensate pump. Condensate pumps are recommended when it is not possible to gravity drain the condensation from the indoor unit. Depending on the pump manufacture the maximum lift for the pump will vary. Consult the pump instructions for the maximum lift for the particular pump being used or refer to specific pump kit information and instructions as supplied by EMI. (Consult Factory.)

Condensation generated by the evaporator will collect in the pumps' reservoir. When the water level is high enough, a float switch will close and energize the pump motor clearing the water from the reservoir. Should for any reason the water exceed the maximum preset level, a safety switch will open, thereby interrupting the (Y) signal to the condenser. This will prevent the evaporator from generating more condensation and spilling out of the unit.

EMI may factory install or supply a detailed field installation kit to follow when pump is purchased as an option from EMI. (If purchased as an add-on in the field, please install per manufacturers instructions included with the pump.)

REMOTE THERMOSTAT OPERATION OPTION (Standard on CCP/CHP)

INFRARED REMOTE CONTROL OPTION OPERATIONAL RANGE 55- 90° F (IN 1° INCREMENTS.)

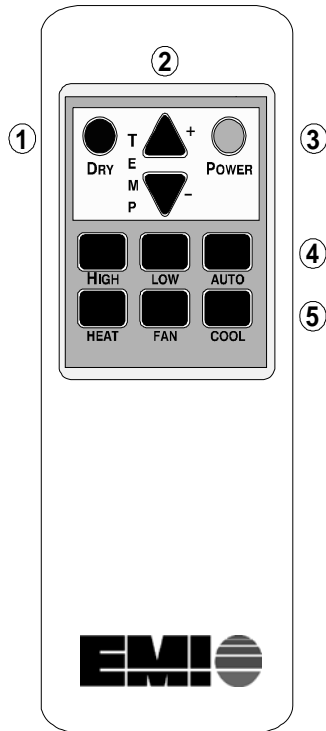

- (1) DRY MODE BUTTON
- (2) TEMP. SET POINT UP/DOWN BUTTON
- (3) POWER ON/OFF BUTTON
- (4) FAN SPEED BUTTONS (HIGH - LOW - AUTO)
- (5) OPERATIONAL MODE BUTTONS (HEAT - FAN - COOL)

NOTE: BATTERIES INCLUDED.

Figure 6

CHOOSING A THERMOSTAT

EMI offers several remote thermostats that are compatible with the Ductless split system air handlers. See the latest price list for a list of available thermostats. It is important to choose a thermostat that will match the equipment that you have selected. For single stage cooling or heating choose a single stage Heat/Cool thermostat. If you have selected an outdoor heat pump unit and an indoor unit with electric heat then chose a two-stage heating, single-stage heat pump thermostat.

SELECTING A THERMOSTAT "Other Than EMI"

When selecting a thermostat other than those offered by EMI, it is important to choose a 24V thermostat that matches your application. EMI equipment is compatible with most mercury bulb, digital or power stealing thermostats.

COOLING ONLY WITH ELECTRIC HEAT OR HYDRONIC HEAT

Select a thermostat that is compatible with a cooling - electric heat system. The thermostat should have "R", "Y", "W" and "G" terminals. The thermostat may also have a "C" terminal.

HEAT PUMP WITH ELECTRIC HEAT

Select a thermostat that is compatible with a cooling, two-stage heat, heat pump system. The thermostat should have "R", "Y", "O", "W (or W2)" and "G" terminals. The thermostat may also have a "C" terminal. If the indoor unit is not equipped with electric or hydronic heat then a single stage heat pump thermostat is adequate.

FAN OPERATION

Some thermostats are equipped with an **auto/on** fan switch. When this switch is placed in the **on** position the indoor fan will run continuous. When the switch is in the **auto** position the indoor fan will cycle with the call for heating or cooling.

FAN PURGE

The indoor unit is equipped an electronic circuit board with a purge feature. After the room thermostat has been satisfied, the purge feature allows the indoor fan to remain on for an additional 60 seconds. This increases efficiency by pulling the remaining energy from the unit.

COOLING OPERATION

The electronic circuit board of the indoor unit also has an anti-short cycle timer (ASCT) feature designed to protect the compressor from short cycling. The ASCT is activated immediately following the off cycle of the outdoor unit. Once the room temperature is satisfied and the outdoor unit switches off, the ASCT will not allow the outdoor to restart unit a three-minute time period has elapsed.

After connecting the thermostat to the unit place the system switch in **cool** mode. Adjust the set-point temperature below the room temperature. The compressor and fan motors will start and cooling will begin. For chilled water systems, the coldwater valve will open allowing the flow of water. Place the set-point temperature above the room temperature. The outdoor condenser will stop (or CW valve will close) while the indoor fan will remain on for an additional sixty seconds.

ELECTRIC HEAT OPERATION

Place the thermostat system switch in **heat mode**. Adjust the set-point temperature above the room temperature. The electric heat will energize along with the indoor fan motor. Heating will continue so long as the set-point remains above room temperature. Next place the set-point temperature below room temperature. The electric heater will switch off and the indoor fan will remain on for an additional sixty seconds.

HYDRONIC HEAT OPERATION (Optional On CHP And FHP Units)

An optional hydronic heat package may be selected in lieu of electric heat. Heating operation is essentially the same as that of units with electric heat. With the thermostat **system switch** set to **heat** and the set-point temperature above room temperature, the hydronic valve will open allowing water to flow through the coil. The indoor fan will also switch on and warm air will flow from the unit. Heating will continue so long as the set-point remains above room temperature. Place the set-point temperature below room temperature. The hydronic valve will close and indoor fan will switch off after the sixty-second purge time has elapsed.

Units with an optional hydronic heat coil or chilled water coil are also equipped with a freeze protection thermostat. The freeze protection thermostat is designed to protect the hydronic coil or chilled water coil from freeze up due to abnormally cold fresh air from the fresh air system or from abnormally cold air from the evaporator coil. Should the freeze sensor activate, the indoor fan will switch off to eliminate the source of cold fresh air, and also the outdoor condenser

unit will be switched off eliminating cold air from the refrigeration system. For units with a hydronic hot water valve installed, the valve will be energized allowing warm water to flow and assist in the defrost process. The system will remain in this state until the freeze condition is satisfied where by the freeze thermostat will reset.

HEAT PUMP (Cooling Mode)

Cooling operation in a heat pump unit is described in "Cooling operation" above. Heatpump condensers are equipped with a reversing valve that is energized for cooling and de-energized for heatpump mode.

OPTIONAL HEAT PUMP WITH ELECTRIC HEAT (2-Stage Heating)

The electronic circuit board of the indoor unit also has an anti-short cycle timer (ASCT) feature designed to protect the compressor from short cycling. The ASCT is activated immediately following the off cycle of the outdoor unit. Once the room temperature is satisfied and the outdoor unit switches off, the ASCT will not allow the outdoor to restart unit a three-minute time period has elapsed.

After connecting the thermostat to the unit place the system switch in **heat** mode. Adjust the set-point temperature above the room temperature. The compressor and fan motors will start and heating will begin. Depending on the thermostat selected, electric heat will also energize when the deviation between room temperature and set point temperature is greater than two degrees. (See the thermostat owner's manual for this feature) Place the set-point temperature below the room temperature. The outdoor condenser and electric heat will stop while the indoor fan will remain on for an additional sixty seconds.

FLOOR MODEL AIR HANDLER (FCP/FHP)



DESCRIPTION

The FHP 09-30 and 36-48 is available in two cabinet sizes with nine capacities in Cooling Only or Heat Pump (depending on condenser match).

FHP units are equipped with a universal control board that allows the unit to operate in either straight cool or heat pump mode. The unit is configured by changing dip switch settings prior to installation.

FHP units are shipped from the factory set in cooling only mode and will need to be reset for heat pump applications.

The FCP is a Chilled Water model with electric or hot water heating options and is compatible with any chilled water source of matching capacity.

The FHP/FCP operates with very low sound levels and is available with several options. It is compatible with any EMI outdoor unit. The FCP is matched with a remote chilled water source, not supplied by EMI.

A unit mounted, electronic, digital control is standard and an optional infrared handheld remote control is available. Fresh air knockouts and anti-short cycle protection are standard features on all FHP units and additional options include supplemental electric or hydronic heat. Operation from a wall thermostat is an available option.

NOTE: Hydronic heat is available only in non-heat pump applications.

SYSTEM OPTIONS

- ETL approved 3-7kw electric heat with safety controls
- Condensate pump, (factory installed)
- Fan-induced fresh air
- Single-stage hydronic heat with sweat connections (not available in heat pump applications; must be factory installed)

NOTE: The FHP utilizes a molded plastic top. DO NOT sit or stand on it as you may damage the unit.

1. Check equipment for damage before mounting.
2. Determine the best location for mounting the unit for optimum air circulation.
3. Locate the indoor and outdoor units as close together as possible (See outdoor unit requirements.)

NOTE: FHP 42 contains Kit# 550-121 that includes a .073" I.D. orifice. The existing factory installed .078" orifice must be replaced when matching the Air Handler with a 36,000 Btuh Condensing Unit. (See the instructions attached to Kit# 550-121 for proper conversion procedure.)

4. Determine the following:
 - Power supply wire routing
 - Interconnect refrigerant piping routing
 - Chilled water and condensate piping routing (FCP)
 - Low voltage control interconnect wiring
 - Fresh air ducting (if required)

NOTE: The large refrigerant line (suction) must be insulated. Allow extra clearance in any opening for this line.

5. If the unit has a field supplied fresh air wall box, make certain that the bottom of the opening is level with the top of the finished floor and ensure that the wall box is pitched slightly toward the outside.
6. Tubing may be run through the knockouts located on the bottom left rear (room side) of the unit, as well through knockouts in the back of the unit.
7. Maximum allowable length and lift of interconnect refrigerant lines can be found in either the instructions for the accompanying outdoor unit or EMI Bulletin #01012 Rev 1: Tubing Run Length Recommendations (to obtain a copy consult your sales rep or distributor.)
8. Consider future servicing of the unit when determining mounting location. All FHP service is performed by removing the front (room side) panels.

MOUNTING PREPARATION

The FHP/FCP is designed to sit directly on a finished floor, flush against a wall. Moldings or baseboard must be cut to allow the unit to be mounted flush against the wall.

Units being installed without a wall box should be test fit for wiring and tubing positions. Place the unit against the wall with the front panels removed. Mark the connection locations on the wall. Shim the unit, if necessary, for square floor to wall positioning.

Units with a wall box (field supplied only for fresh air) must be checked to ensure the unit is level and the floor of the wall box is pitched down and away from the unit. The drip edge of the wall box must clear the edge of the finished outside wall (See *Figure 1 – Wall Box Positioning*). EMI recommends that all electrical, refrigerant, and condensate lines are routed through the wall or floor to the correct locations to use the knockouts before the unit is mounted in place.

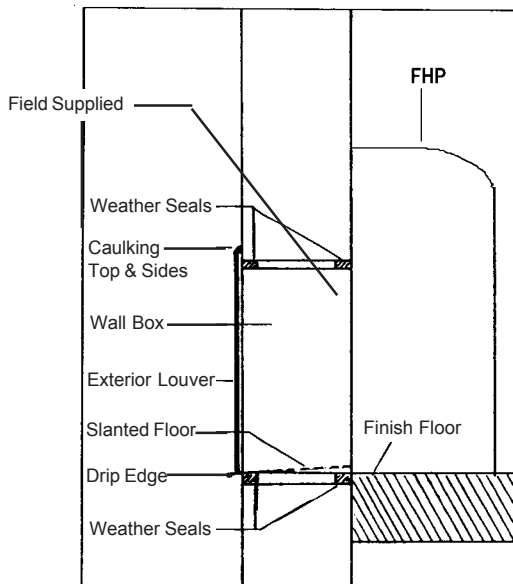

Figure 1- Wall Box Positioning

Figure 7

ITEMS FOR CONSIDERATION

- EMI's FHP evaporator requires 24V power for control operation. When matching the FHP with a non-EMI condenser, a 24V transformer may need to be added to the condenser.
- Ensure that the FHP interconnect tubing is within a maximum allowable length of 100' including, a maximum 35' lift.

OPEN FRESH AIR UNIT PREPARATION

If a fresh air connection is necessary for this FHP/FCP installation, please note the following:

- All ducts, collars, and dampers are field supplied. The back side has a 4" knockout for a fresh air duct.
- Block the opening during installation to prevent foreign objects from getting into the unit.
- The duct should be installed with a slight downward pitch away from the unit to prevent moisture from entering the unit.

Secure the unit to the wall using lag screws or other appropriate anchor devices. Then connect all wiring and tubing connections.

REFRIGERANT PIPING

The FHP is equipped with a Flo-Rater/Piston Expansion Device. Connections are male flare type.

The suction line (large) must be insulated the entire length with closed cell, foam tube insulation. Do not insulate the liquid line (small). Connect the outdoor unit according to the instructions supplied with unit.

All horizontal piping runs must be level and without dips to trap the oil.

FLOOR MODEL AIR HANDLER (FCP/FHP) *Continued*

PIPING DO'S AND DON'TS

- Avoid piping on a rainy day.
- Use refrigerant grade copper tubing.
- Use a tubing bender and avoid unnecessary bending.
- Cap ends of lines until ready for final connections.
- Install a P-trap for every 10' of vertical rise.

REFRIGERANT PROCESSING

WARNING: It is illegal to discharge refrigerant into the atmosphere. Use proper reclaiming methods and equipment when installing or servicing this unit.

Finish all pipe connecting before proceeding to charging the system. Follow the instructions in the outdoor unit for line evacuation, opening service valves, and final charge adjustments. Operation charts and charge tables can be found in the EMI Condenser IOMs.

CHILLED WATER PIPING

Standard connections provided are sweat type. See specifications for line size and actual unit connections.

NOTE: Water pipe sizes are given in I.D.

- Use pipe unions or compression fittings to aid future service. Use isolation valves to aid in unit removal.
- Connections can be brazed or soft solder type.
- Follow manufacturer's instructions for any field installed control valves.

- Unit control is provided for a 24V normally closed/ power open valve (20VA max.)
- *Consult factory if other types of valves are used.*
- Insulate supply and return piping with closed cell foam tube insulation.
- Avoid unnecessary bends or kinks (use a tubing bender)
- Make sure glycol solution is compatible with all valves, unions and compression fittings. Ethylene or propylene is recommended.
- Bleed air from system prior to start-up, units are equipped with a standard air bleeder on the highest point on the unit piping.

CAUTION: Disconnect power when bleeding system. Make certain liquid does not contact any electrical components.

Finish all piping before balancing the system. Bleed system, adjust temperature and/or water flow rate until desired results are achieved.

NOTE: Please refer to the Common section in the front of this manual for detailed instructions on: Controls/Components, Electrical Wiring, Start-Up, and more.

FCP/FHP DIMENSIONS AND SPECIFICATIONS

NOTE: Due to ongoing development programs, design and specifications may change without notice.

FCP Piping Specifications

Model#	Chilled Water Line Size (Supply & Return)	Drain Hose
9,12,15	½" I.D.	½" I.D.
18,24	5/8" I.D.	5/8" I.D.
30	¾" I.D.	5/8" I.D.
36,42,48	¾" I.D.	5/8" I.D.

FCP/FHP Discharge Air Speed And Throw

Model#	CFM Low/High	Coil	FPM	Throw/ft.
9,12,15	350/375	dry	800	12.4
18,24,30	480/700	dry	1500	18.6
36,42,48	1000/1200	dry	1500	19

FCP/FHP Power Assisted Outside Air

Model#	Total CFM	Outside Air CFM
9, 12, 15	440	180
18, 24, 30	725	200
36, 42, 48	1200	400

FCP/FHP Sound Levels

Model#	DbA
9, 12	48.6
15	56
18	57.2
24, 30	60.6
36, 42, 48	63.2

(FCP/FHP) DIMENSIONS AND SPECIFICATIONS *Continued*

NOTE: Due to EMI's ongoing development programs, designs and specifications may change without notice.

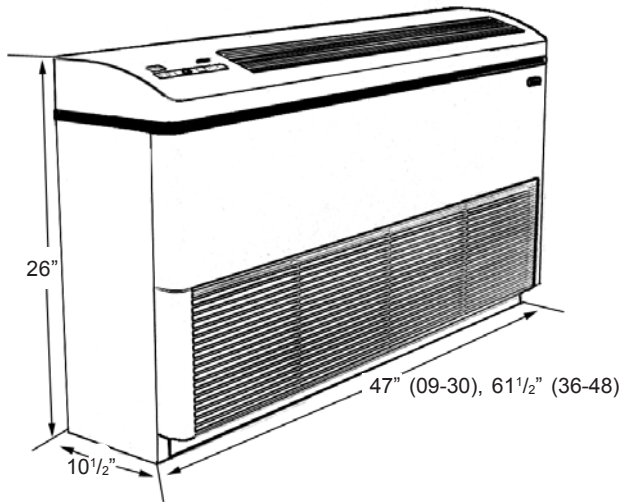

FCP/FHP Fresh Air Specifications*

Model#	Total CFM	Outside Air CFM
9, 12, 15	440	50
18, 24, 30	725	75
36, 42, 48	1200	160

* Open or Motorized Damper

FCP/FHP Electrical Specifications

Model#	Voltage/Hz/Ph	Fan FLA	Min. Ampacity*	Max. Fuse*
9, 12A	115/60/1	1.5	1.9	15
9, 12, 15	208-230/60/1	0.6	0.8	15
18, 24	208-230/60/1	0.8	1	15
30	208-230/60/1	1.1	1.4	15
36, 42, 48	208-230/60/1	1.1/1.1	2.5	15

(*) If electric heat is installed, use data from *FHP Electric Heat Specifications* table.

FCP/FHP Electric Heat Specifications

Model#	Voltage	KW	Heater Amps	Total Amps	Min. Circuit Amps	Max. Fuse Amps
9, 12, 15	230	3	13.1	13.7	17.1	20
18, 24	230	5	21.7	22.7	28.2	30
30	230	5	21.7	22.8	28.6	30
36, 42, 48	230	7	30.4	32.6	40.6	45

FHP Piping Specifications

Model#	Refrigerant Line Size		Drain Hose
	Liquid	Suction	
9, 12	1/4"	1/2"	1/2" I.D.
15	1/4"	5/8"	5/8" I.D.
18	3/8"	5/8"	5/8" I.D.
24	3/8"	3/4"	5/8" I.D.
30	3/8"	3/4"	5/8" I.D.
36, 42, 48	3/8"	7/8"	5/8" I.D.

FHP Shipping Wt.

Model#	LBS.
9, 12, 15	110
18, 24, 30	120
36, 42, 48	165

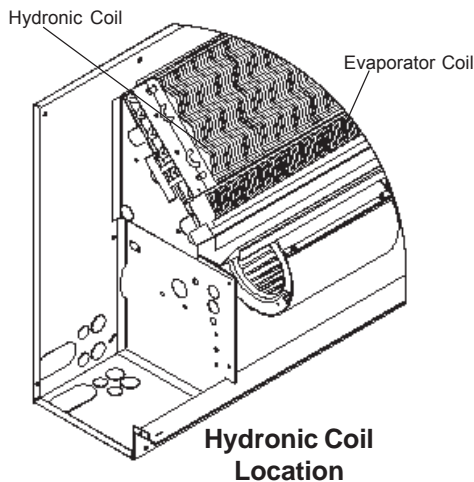

FCP/FHP Hydronic Heat Specifications

(Single-stage Heating only)

Model#	EWT °F	Btuh	GPM	PD (PSI)
9, 12, 15	180	24,300	2	3.4
	140	18,400	2	3.4
18, 24, 30	180	41,500	3.5	5.6
	140	26,200	3.5	5.6
36, 42, 48	180	62,400	6	8.8
	140	39,500	6	8.8

NOTE: Not available with Heat Pump applications.

FHP's ONLY



(FCP/FHP) DIMENSIONS AND SPECIFICATIONS *Continued*

Connection K.O.s for Open Fresh Air

FHP 09-30

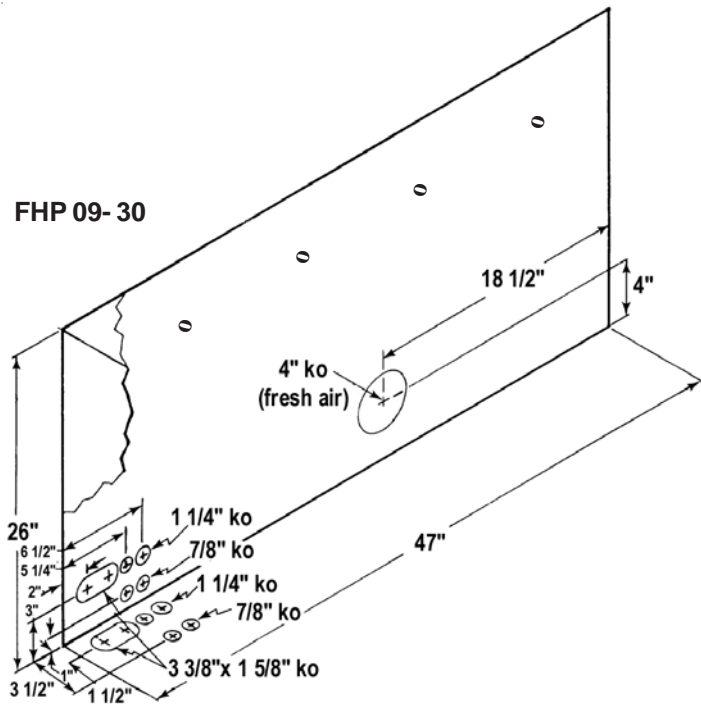

FHP 09-30 Motorized Damper and Power Assisted Fresh Air (2 Fan Type)
 Wall Box Dimensions: 14" (from finished floor level) x 17" wide x 8" deep

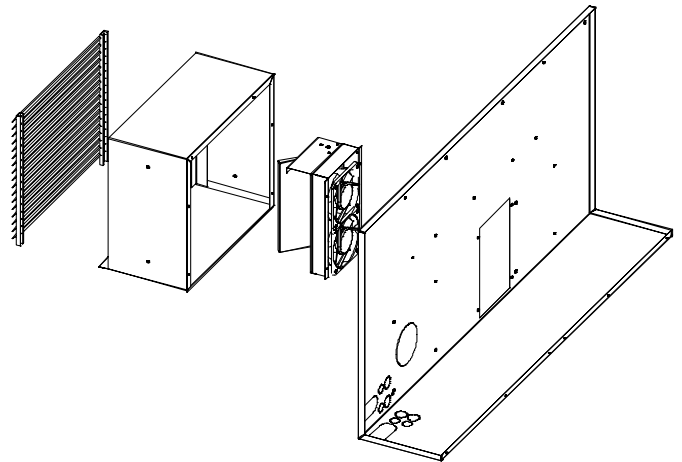

Lagging holes positioned 8" on center for optional mounting

FHP 36-48

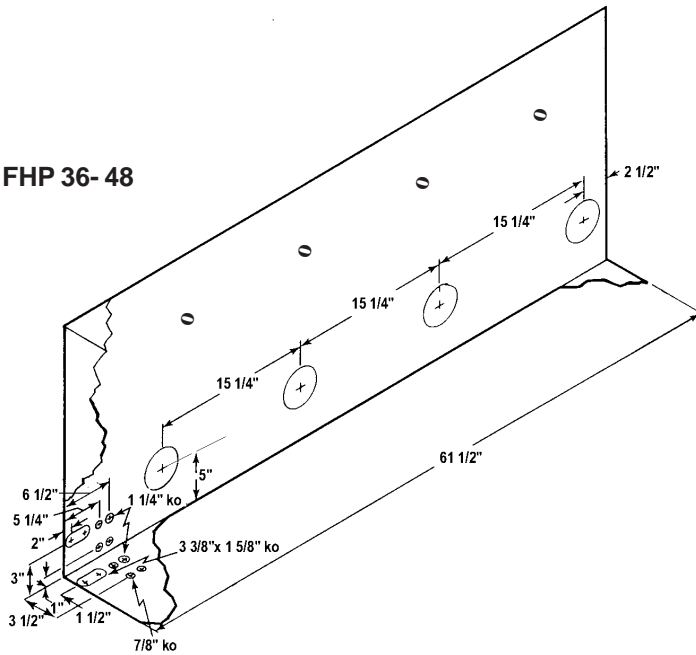

FHP 36-48 Motorized Damper and Power Assisted Fresh Air (4 Fan Type)
 Wall Box Dimensions: 14" (from finished floor level) x 32" wide x 8" deep

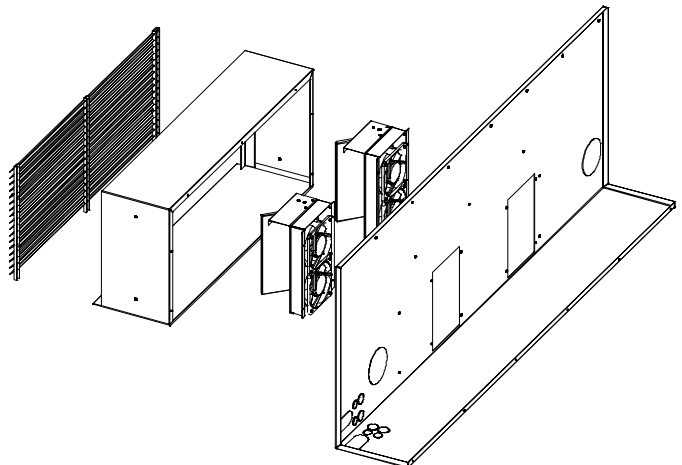

CEILING MOUNTED AIR HANDLER (CCP/CHP)



DESCRIPTION

The EMI CCP/CHP is a highly effective ceiling mounted evaporator for applications where fully exposed or partially recessed cabinetry can be used. For partially recessed mounting, these units easily adapt to standard T-bar, drop-ceiling openings. The CCP/CHP is designed for residential and commercial applications where the unit may be concealed in soffits or other structural spaces with only the intake and discharge grilles exposed. When concealing the unit make provisions to the soffit for future access to the unit for maintenance purposes. When offering the Infra-Red Control option, due to the fact that the infra-red receiver is located on the unit, the CHP model cannot be mounted in a soffit or another structural space.

The aluminum supply air louvers are dual adjustable for air flow direction, to provide air flow throws to suit any installation. The louvers are mounted in a high impact polystyrene front section. The CHP incorporates dual blowers that produce efficient, quiet operation, suitable for both residential and commercial applications. A wide range of options are available for the CCP/CHP units, including supplemental electric or hydronic heat options, a factory or field installed condensate pump, and optional digital and hand held IR remote controls.

The CCP is a ceiling mounted, chilled water air handler that is simple to install with standard 24V control circuits to the chilled water supply. Hanging brackets and fresh air openings are also standard on all models. Optional trim kits are available for surface mounting applications.

The CHP Heat Pump models are two stage heating units when back up resistance heat (3, 5, or 7KW depending on unit capacity) is supplied. This is only when mated with EMI SHC/CHD Series heat pump condenser.

NOTE: If equipped with hydronic heat, the CHP will only operate as a single-stage heating unit and not as a two-stage heating unit.

NOTE: Refer to installer supplied items on page 3 of Common section.

MOUNTING PREPARATION

Choose the best location for the unit. Use the cardboard template (provided with unit packing) to "test fit" the unit before installation.

1. The CCP/CHP Series is designed to be mounted to a horizontal surface which should be plumb and level.
2. Using the template, mark a spot where the piping should penetrate the wall.
3. Determine appropriate hole size and cut through the mounting surface.

Piping for new construction can be roughed in before wall-board or panels are put in place. PVC pipe may be used as a pipe chase.

MOUNTING

1. Remove access panel, attach the front panel and louvers to the chassis section with supplied nuts.
- NOTE: Front panel shipped separately in cartoning.**
2. Secure the unit to the ceiling using appropriate hardware (screws for wood, anchors for masonry).
 3. The CHP unit can be ceiling suspended using threaded rods and double nuts to ensure fasteners won't loosen.
 4. Pitch the unit slightly towards the drain for proper condensate removal.
 5. Run power wiring and refrigerant lines (chilled water for CCP) into the unit.

ITEMS FOR CONSIDERATION

- EMI's CHP evaporator requires 24V power for control operation. When matching the CHP with a non-EMI condenser, a 24V transformer may need to be added to the condenser.
- Ensure that the CHP interconnect tubing is within a maximum allowable length of 100' including, a maximum 35' lift.

REFRIGERANT PIPING

CHP units are equipped with a piston flow regulator expansion device. Piping connections are standard flare type.

NOTE: See specifications for line sizing and actual unit connections.

1. Be certain there are no burrs on either side of the tubing.
2. The large line (suction) should be insulated with closed cell foam tube insulation. Do not insulate the small liquid line.

PIPING DO'S AND DON'TS

- Avoid piping on a rainy day.
- Use refrigerant grade copper tubing.
- Use a tubing bender and avoid unnecessary bending.
- Cap ends of lines until ready for final connections.
- Install a P-trap for every 10' of vertical rise.

NOTE: Connections to outdoor sections should be made according to the outdoor section installation instructions.

FRESH AIR

This is a 4" round knockout and will accept a 4" round duct. Dampers, wall collars, and outdoor grilles are field supplied. Do not allow moisture or other foreign matter to enter through the fresh air intake. When ducting, pitch slightly to the outside to prevent moisture from entering the chassis.

(CCP/CHP) DIMENSIONS AND SPECIFICATIONS *Continued*

NOTE: Due to ongoing development programs, design and specifications may change without notice.

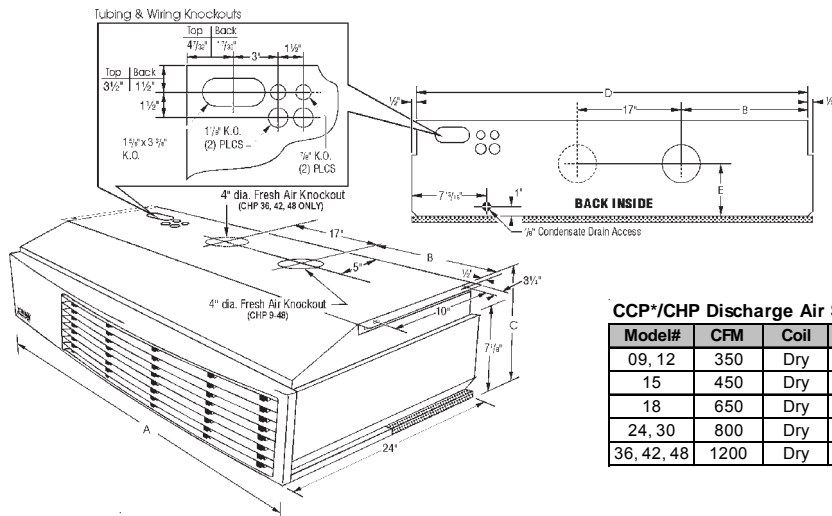

CHP's ONLY



CCP*/CHP Discharge Air Speed and Throw

Model#	CFM	Coil	FPM	Throw/Ft.
09, 12	350	Dry	290	12.4
15	450	Dry	375	12.4
18	650	Dry	430	18.6
24, 30	800	Dry	533	18.6
36, 42, 48	1200	Dry	500	19

CCP*/CHP Physical Dimensions and Piping Specifications

Model#	Width "A"	Width "B"	Width "C"	Width "D"	Width "E"	Drain Hose	Shipping Wt.	CHP's ONLY		CCP PIPING ONLY*
								Ref. Line Sizes		CW Line Size (Supply & Return)
								Liquid	Suction	
09,12	42"	16 1/2"	10 3/4"	41"	5 1/2"	1/2" I.D.	115	1/4"	1/2"	1/2" I.D.
15	42"	16 1/2"	10 3/4"	41"	5 1/2"	1/2" I.D.	135	1/4"	5/8"	N/A
18	49"	19"	10 3/4"	48"	5 1/2"	5/8" I.D.	135	3/8"	5/8"	5/8" I.D.
24	49"	19"	10 3/4"	48"	5 1/2"	5/8" I.D.	135	3/8"	3/4"	5/8" I.D.
30	49"	19"	10 3/4"	48"	5 1/2"	5/8" I.D.	135	3/8"	3/4"	3/4" I.D.
36, 42, 48	59"	16 1/8"	12 3/4"	58"	7 1/2"	5/8" I.D.	160	3/8"	7/8"	3/4" I.D.

*The CCP Model dose NOT come in a 15,000 Btuh unit.

CCP*/CHP Electrical Specifications

Model#	Voltage	Hertz	Fan FLA	Min. Ampacity	Max. Fuse (1)
09A	115	60	1.4	1.8	15
09D	208/230	60	0.6	0.8	15
12A	115	60	1.4	1.8	15
12D	208/230	60	0.6	0.8	15
15D	208/230	60	0.6	0.8	15
18D	208/230	60	1.1	1.4	15
24D	208/230	60	1.1	1.4	15
30D	208/230	60	1.1	1.4	15
36D	208/230	60	1.1/1.1	2.5	15
42D	208/230	60	1.1/1.1	2.5	15
48D	208/230	60	1.1/1.1	2.5	15

(1) If electric heaters are installed, use Min Amp and Max Fuse from Heater Options Chart.

CCP*/CHP with Electric Heat Options

Model#	Voltage	KW	Htr Amps	Total Amps	Min. Cir. Amps	Max. Fuse
09, 12, 15	208/230	3	13.1	13.7	17.1	20
18, 24, 30	208/230	5	21.7	22.8	28.6	30
36, 42, 48	208/230	7	30.4	32.6	40.8	45

CCP*/CHP Hydronic Heat Specifications

(Single-stage Heating Only)

Model#	EWT °F	GPM	Btuh	PD R. Wtg
09, 12	140	2	14,500	3.4
	180	2	22,900	3.4
15	140	2	16,200	3.4
	180	2	25,800	3.4
18, 24	140	4	27,200	5.2
	180	4	43,200	5.2
30	140	4	29,800	5.2
	180	4	47,300	5.2
36, 42, 48	140	4	40,300	6.1
	180	4	64,100	6.1

NOTE: CHP 42 contains Kit# 550-121 that includes a .073" I.D. orifice. The existing factory installed .078" orifice must be replaced when matching the Air Handler with a 36,000 Btuh Condensing Unit. (See the instructions attached to Kit# 550-121 for proper conversion procedure.)

CCP CAPACITIES

Unit	Total Capacity	Sensible Capacity	Fluid Temp.	Fluid Flow	PD Psi
CCP 09/12	7900	7300	45	1.0	3.0
	10900	8800	45	2.0	5.3
	13300	9800	45	3.0	8.8
CCP 18/24	9000	7800	40	1.0	3.0
	12700	9500	40	2.0	5.3
	15600	10700	40	3.0	8.8
CCP 24/30	17400	15000	45	3.0	3.4
	22500	17200	45	5.0	10.1
	19000	15100	40	3.0	3.4
CCP 24/30	26600	19700	40	5.0	10.1
	21600	17000	45	3.0	4.8
	26750	19500	45	4.5	10.2
CCP 24/30	29500	20600	45	6.0	17.2
	25000	18600	40	3.0	4.8
	31000	21500	40	4.5	10.2
CCP 36/42/48	34512	28430	45	4.0	6.4
	42872	32080	45	6.0	13.3
	47364	33977	45	8.0	22.6
CCP 36/42/48	39081	30341	40	4.0	6.4
	49981	35067	40	6.0	13.5
	56292	37832	40	8.0	22.8

All capacities based on high speed fan and 80° F dry bulb/ 67° F wet bulb entering air temperature.

NOTE: Please refer to the Common section in the front of this manual for detailed instructions on: Controls/Components, Electrical Wiring, Start-Up, and more.

CORNER MOUNTED AIR HANDLER (CNR)



DESCRIPTION

EMI's corner mounted air handler (CNR) is revolutionary in its state-of-the-art design as a ductless evaporator that can be mounted inconspicuously in the corner of most any room. Using mounting holes on the unit that are set up to align with any wall construction (including walls with non-square corners), the CNR utilizes previously unused wall space for effective high efficiency room conditioning with whisper quiet operation.

The CNR is equipped with unit mounted infrared compatible controls and can easily be installed in small to mid-size commercial or residential spaces by one person using the supplied positioning bracket. Heat pump models provide up to a nominal 12,000 Btuh of cooling/heating and a 3KW electric heat option is available. Other design features include dual supply airflow and versatility of tubing and wiring access through multiple entrances on the unit.

OPTIONAL EQUIPMENT

- Integral condensate pump
- Hand held infrared controller
- Wall mounted thermostat control
- 3KW electric heat with automatic reset high temperature cutout
- Temperature fuse link
- Top trim kit for finished look between unit and ceiling
- 24V transformer (see below)

ITEMS FOR CONSIDERATION

- EMI's CNR evaporator requires 24V power for control operation. When matching the CNR with a non-EMI condenser, a 24V transformer may need to be added to the condenser.
- Ensure that the CNR interconnect tubing is within a maximum allowable length of 100' including, a maximum 35' lift.

UNIT MOUNTING

It is recommended that the CNR be mounted 3" from the ceiling, allowing proper access to the components located in the top of the unit. The CNR must be mounted plumb and level to a vertically square surface to prevent unit vibration and/or unwanted noise. It is recommended that the unit be mounted directly to a smooth surface of sheetrock wallboard or similar material. If mounting to a block wall, there should be a smooth square backing between the unit and the block surface to absorb any potential vibration.

IMPORTANT: *If excessive noise or vibration is experienced from a unit mounted directly to a block wall, the squareness of the wall should be checked immediately.*

With the CNR, tubing, electrical, and drain access may be acquired through either the bottom left or right sides or the top of the unit. Keep in mind when routing through the top of the unit through a ceiling that there is a 2 ½" knockout provided in the top panel for this access. If you are using only the top tubing access it will be necessary to install a condensate pump.

NOTE: *An optional top trim kit is available for concealing tubing and/or wiring run through the top of the unit. In addition, this kit may be used to provide a finished look between the unit and the ceiling. To effectively use the top trim kit, the CNR must be mounted 3" from the ceiling.*

Piping may be roughed in before wallboard or panels are placed in new construction. PVC (3" or 4" I.D.) may be used as a pipe chase.

After determining the best location for the unit, use the right and left paper wall-mounting templates included with this instruction manual for proper unit mounting. After adhering the right and left templates to the wall at the proper height (3" from ceiling), these templates will be used to center mark and pre-drill necessary holes indicated on the templates. Once the holes are drilled, mark/cut holes for tubing and electrical access and remove the templates from the walls. The Installer will determine if wall anchors are necessary.

Included with the CNR is a mounting hardware kit consisting of two 5/16 x 4" lag screws/washers, six #12 x 1-1/4" Phillips head screws/washers, and six #12 wall anchors. Use two #12 x 1-1/4" Phillips head screws and wall anchors to secure the positioning bracket in place on the wall according to the proper hole location indicated on the templates. The positioning bracket is provided for temporarily hanging the unit at the proper height. Use a ¼" drill for drilling holes for the anchors supplied for sidewall and positioning bracket mounting. It is not necessary to use the remaining wall anchors for sidewalls if mounting directly to the wall studs.

CORNER MOUNTED AIR HANDLER (CNR) *Continued*

Once the positioning bracket is secured, mount the unit to the bracket and make certain it fits properly. Remove the front perforated panel to access the inside of the unit for mounting. Lag screws and washers are provided to secure the unit to the corner of the wall. The installer will determine whether or not wall anchors (provided by the installer) are required. Once the unit is mounted to the corner, there are 2 slots on either side of the chassis which are used to secure chassis sides to the walls. For walls that are not square, the screws should be tightened just enough to evenly space each side. Do not over tighten.

INDOOR UNIT DRAINAGE

After the indoor unit has been installed, make sure that condensed water is properly drained. If this is neglected, the unit may become flooded.

Special Care Should Be Given To The Following Details When Routing The Drain Line:

- The free end of the hose must not be tilted upward or put into water.
- A trap or kink must not be used.
- The drain hose must slope downward to the outdoor side.
- The end of the drain hose must never be put into water.

ELECTRICAL WIRING

All electrical wiring should be performed by a licensed electrician and must be in accordance with NEC and local codes. Check the unit rating plate for circuit ampacity and breaker or fuse size and use only HACR-type breakers. Select the proper wire for the ampacity rating. Refer to the wiring diagram(s) packed with each unit.

1. High voltage power connections are made inside the control box. Supply wires enter through one of two 7/8" knockout holes. A terminal block marked with L1 and L2 and a ground lug are provided.
2. Low voltage wiring (EMI requires 18 awg low voltage interconnect wiring) must be run to the outdoor unit. Refer to the unit wiring diagram for details. These

wires may be attached to the refrigerant lines when inserting through the wall/ceiling opening. The CNR evaporator requires 24V power for control operation. When matching the CNR with a non-EMI condenser, a 24V transformer may need to be added to the condenser.

3. Some models are made for connection to a remote thermostat. This will require running low voltage wiring to the thermostat and from the thermostat to the outdoor unit.

OUTDOOR SECTIONS

The CNR is compatible with EMI condensing units and does not contain a low voltage transformer as standard. Consult the factory for other straight cool condensing applications. EMI will not warranty non-EMI heat pump units with EMI evaporators. Make connections for the indoor and outdoor units according to the wiring diagrams included with the units.

REFRIGERANT PIPING

The CNR is equipped with a piston flow regulator expansion device. Piping connections are standard sweat type.

IMPORTANT: *See specifications for line sizing and actual unit connections.*

1. Be certain there are no burrs on either side of the tubing.
2. The large suction line should be insulated with closed cell foam tube insulation. Do not insulate the small liquid line.

CONTROLS AND COMPONENTS SPECIFIC TO CNR

- Relays/connections for condensing unit
- Positioning bracket, templates, and mounting hardware

NOTE: *Please refer to the Common section in the front of this manual for detailed instructions on: Controls/Components, Electrical Wiring, Start-Up, and more.*

(CNR) DIMENSIONS AND SPECIFICATIONS

NOTE: Due to ongoing development programs, design and specifications may change without notice.

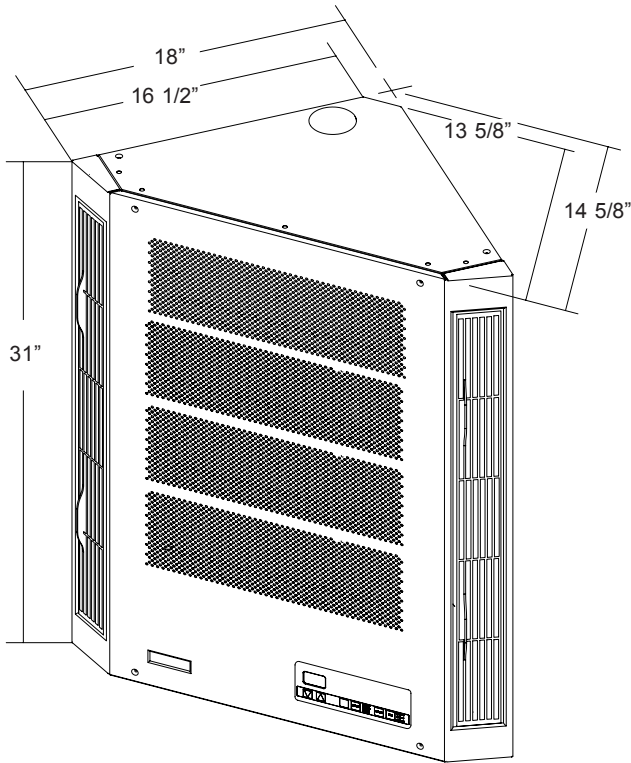

SHIPPING WEIGHT = 70 POUNDS

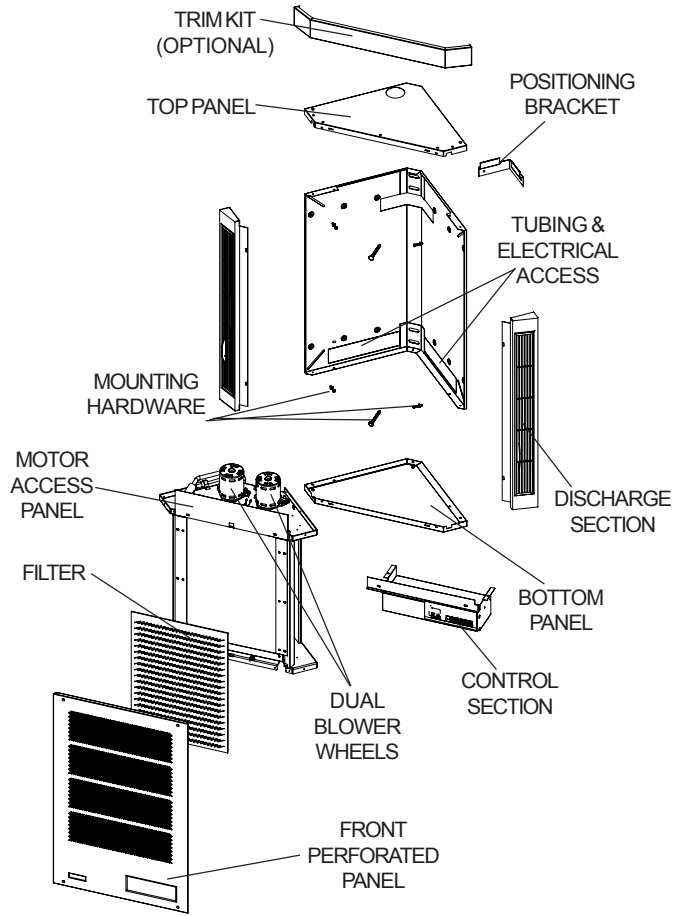

ELECTRICAL SPECIFICATIONS

MODEL	VOLTS/HZ/PH	ELECTRIC HEAT		INDOOR FAN#1		INDOOR FAN#2		TOTAL AMPS	MCA	MAX FUSE
		WATTS	AMPS	H.P.	FLA	H.P.	FLA			
WITH ELECTRIC HEAT	115/60/1	750	6.52	0.02	0.6	0.02	0.6	7.7	9.6	15
	208-230/60/1	3000	13.04	0.02	0.34	0.02	0.34	13.7	17.1	20
WITHOUT ELECTRIC HEAT	115/60/1	N/A	N/A	0.02	0.6	0.02	0.6	1.2	1.4	15
	208-230/60/1	N/A	N/A	0.02	0.34	0.02	0.34	0.7	0.8	15

DISCHARGE AIR SPEED AND FLOW

COIL	CFM		FPM		THROW/FT.	
	LOW	HIGH	LOW	HIGH	LOW	HIGH
DRY	335	370	700	750	10	12

OBSERVED SOUND

LOW	HIGH
48 DbA	49 DbA

INTERCONNECTING REFRIGERANT LINE SIZES

LIQUID	SUCTION
1/4"	1/2"



WALL MOUNTED AIR HANDLER (WCP/WHP)



PRODUCT DESCRIPTION

The WHP is a ductless type evaporator, while the WCP is a chilled water air handler, both have a contemporary design with an attractive appearance to fit any décor. They offer high efficiency conditioning of small to mid-size commercial or residential spaces. The WHP/WCP is equipped with unit mounted infrared compatible controls; an optional hand held remote is available.

WHP/Heat Pump models provide up to a nominal 33,000 Btuh of cooling and 36,000 Btuh of heating. Electric heat options are available for up to 5KW of supplemental heat. The WCP/Chilled Water models provide up to a nominal 30,000 Btuh of cooling. Electric Heat options are available for up to 5KW of supplemental heat. It can be paired with a matching capacity chilled water source (non factory supplied).

Check page 3 in common section of this manual for a list of Controls and Components .

Check page 6 in common section of this manual for a list of Optional Controls and Components .

NOTE: Unit mounted controls are fully functional without the remote.

INSTALLER SUPPLIED ITEMS

- Power wiring (high and low Voltage)
- Mounting hardware
- Refrigerant piping (if not supplied)
- Refrigerant (for interconnect charge)

NOTE: Please refer to the Common section in the front of this manual for detailed instructions on: Controls/Components, Electrical Wiring, Start-Up, and more.

ITEMS FOR CONSIDERATION

- Check equipment for damage prior to installation. A foam block has been placed under the blower wheel to prevent shipping damage. Be sure to remove the foam block before starting the unit.
- Determine the best location for mounting the unit and room air circulation. Locate outdoor and indoor units as close together as possible.
- Determine how refrigerant and power line may be run to and from unit.
- Determine if the cabinet front can be removed without obstruction.
- Ensure that the WHP interconnect tubing is within a maximum allowable length of 100' including, a maximum 35' lift.
- EMI's WHP evaporator requires 24V power for control operation. When matching the WHP with a non-EMI condenser, a 24V transformer may need to be added to the condenser.

UNIT MOUNTING

The WHP/WCP must be mounted plumb and level to a vertically square surface to prevent unit vibration and/or unwanted noise. It is recommended that the WHP be mounted directly to a smooth surface or sheetrock wallboard or similar material. If mounting to a block wall, there should be a smooth square backing between the unit and the block surface to absorb any potential vibration.

NOTE: If excessive noise or vibration is experienced from a unit mounted directly to a block wall, the squareness of the wall should be checked immediately.

After determining the best location for the unit, use the cardboard template provided in the packaging to mark a spot where the piping should penetrate the wall. Then determine the appropriate hole size and cut through the wall.

NOTE: Piping may be roughed in before wallboard or panels are placed in new construction. PVC pipe (3" or 4" I.D.) may be used as a pipe chase.

The WHP may be mounted by using the supplied wall bracket. Secure the bracket to the wall with the appropriate screws (for wood) or anchors (for masonry) and, once secured, mount the unit to the bracket and make certain it fits properly.

NOTE: The wall hanging bracket slot is NOT located in the center of the unit.

NOTE: Panels should remain on the unit at all times. Service should be performed by a QUALIFIED service agency. An annual system check by a qualified service technician is recommended.

(WCP/WHP) DIMENSIONS AND SPECIFICATIONS

NOTE: Due to ongoing development programs, design and specifications may change without notice.

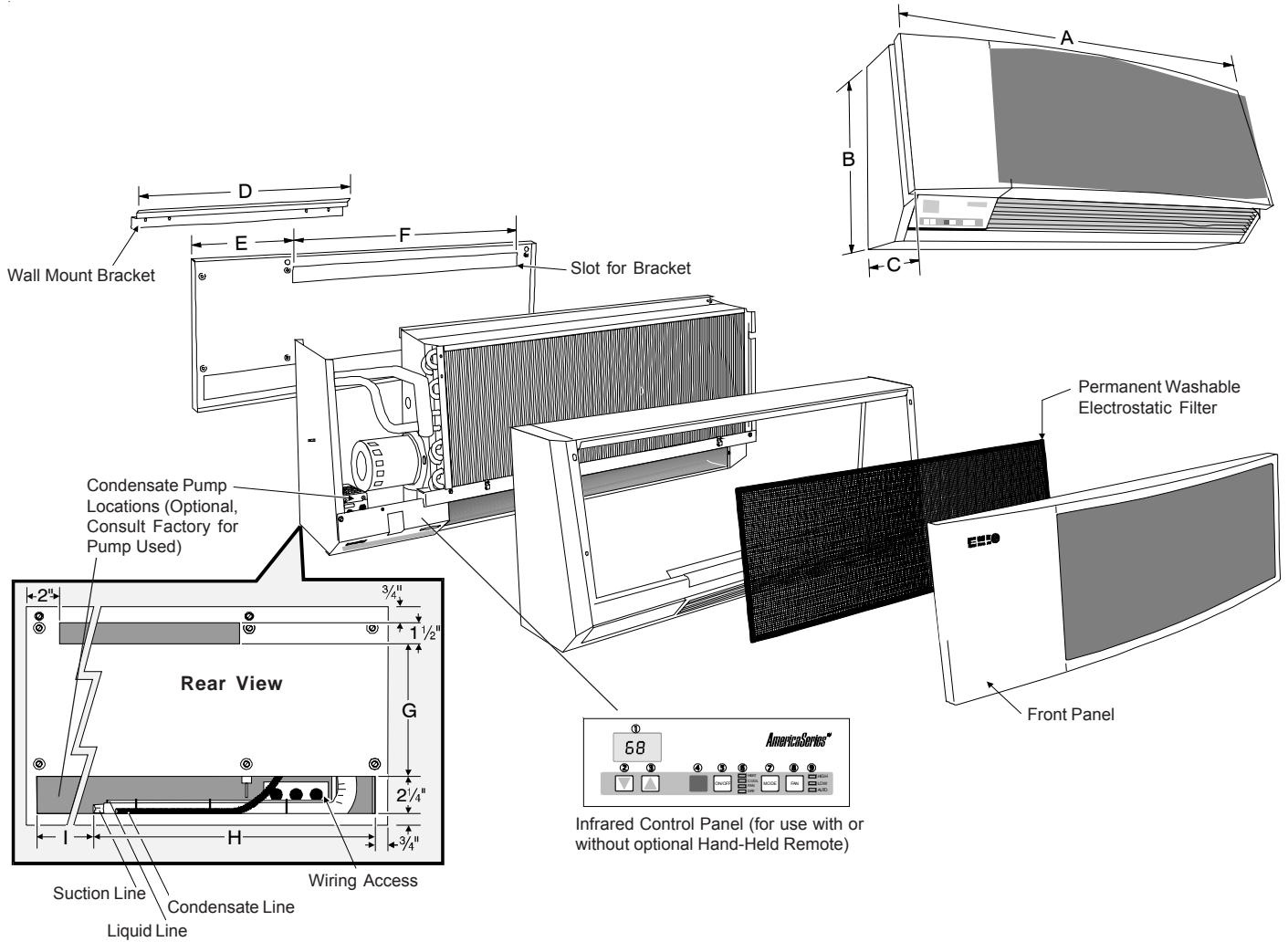

WCP/WHP PHYSICAL DIMENSIONS

Model	Width "A"	Height "B"	Depth "C"	Width "D"	Width "E"	Width "F"	Width "G"	Width "H"	Width "I"	Shipping Wt.
09/12	36½"	14½"	10¾"	32"	9"	24½"	8"	18"	16"	85
15/18	47½"	14½"	10¾"	32"	10"	34½"	8"	18"	27"	115
24/30	57½"	14½"	10¾"	42"	10"	44½"	8"	27"	28"	115
36	57½"	17"	11¼"	42"	10"	44½"	10½"	25"	28½"	115

(WCP/WHP) DIMENSIONS AND SPECIFICATIONS

WHP ELECTRICAL SPECIFICATIONS

Model	Voltage	Hertz	Fan FLA	Min Amp ⁽¹⁾	Max Fuse ⁽¹⁾
9/12	115	60	0.7	0.8	15
	208/230	60	0.34	0.43	15
15-36	115	60	1.2	1.5	15
	208/230	60	0.56	0.7	15

(1) If electric heaters are installed, use Min Amp and Max Fuse from Heater Options Chart.

WCP ELECTRICAL SPECIFICATIONS

Model#	Volts/HZ/P hase	Fan		Total Amps	Min. Volt	Min. Ampacity ⁽¹⁾	Max Fuse ⁽¹⁾
		FLA	HP				
09A, 12A	115/60/1	0.64	0.03	0.64	104	0.8	15
09D, 12D	208/230/60/1	0.34	0.02	0.34	197	0.43	15
15A, 18A	115/60/1	1.2	0.083	1.2	104	1.5	15
15D, 18D	208/230/60/1	0.56	0.07	0.56	197	0.7	15
24A, 30A	115/60/1	1.2	0.083	1.2	104	1.5	15
24D, 30D	208/230/60/1	0.56	0.07	0.56	197	0.7	15

(1) If electric heaters are installed, use Min Amp and Max Fuse from Heater Options Chart.

WCP/WHP ELECTRIC HEAT OPTIONS

Model	Voltage	KW	Heater Amps	Total Amps	Min. Cir. Amps	Max Fuse
9/12	230	3	13.1	13.5	16.8	20
15/18	230	3	13.1	13.6	17	20
24/30	230	5	21.7	22.3	27.9	30
36	230	5	21.7	22.3	27.9	30

WCP/WHP CONNECTIONS

Model	Refrigerent Line Size		Chilled Line Size I.D.
	Liquid	Suction	
9/12	1/4"	1/2"	1/2"
15	1/4"	5/8"	5/8"
18	3/8"	5/8"	5/8"
24/30	3/8"	3/4"	3/4"
36	3/8"	7/8"*	—

* WHP Suction Connection is 3/4" O.D. and must be bushed down at the WHP Unit.

WCP CAPACITIES

Model	Total Capacity	Sensible Capacity	Fluid Temp.	Fluid Flow	PD RH20
09, 12	7,375	6,732	45	1	0.8
	10,801	8,272	45	2	3.8
	13,270	9,279	45	3	8.0
	8,387	7,189	40	1	0.8
	12,481	8,950	40	2	3.9
	15,643	10,304	40	3	8.1
15, 18	15,624	13,477	45	2	4.4
	19,761	15,367	45	3	9.1
	17,724	14,379	40	2	4.5
	23,073	16,763	40	3	9.3
24, 30	20,563	17,564	45	3	2.3
	29,031	21,178	45	6	8.3
	32,320	22,539	45	9	17.7
	23,600	18,887	40	3	2.4
	34,400	23,423	40	6	8.4
	38,790	25,351	40	9	17.9

DISCHARGE AIR SPEED AND FLOW (230V High Speed Fan)

Model	CFM	Coil	FPM	Throw/Ft.
9/12	310	Dry	960	16
15/18	600	Dry	1412	26
24/30	750	Dry	1400	25
36	750	Dry	1400	25

WCP/WHP OBSERVED SOUND (230V High Speed Fan)

Model	DbA
9/12	48
15/18	51
24/30	54
36	54

WHP's ONLY



MAINTENANCE AND TROUBLESHOOTING PROCEDURE

for EMI Air Handlers with Unit Mount Infrared Controls

MAINTENANCE

Service should be performed by a **qualified** service agency and an annual system check is recommended. EMI units are designed and constructed for reliability and long life with minimal maintenance. You can insure peak operating efficiency by:

1. Cleaning air filters on a monthly basis: The filter is accessed by removing the air intake access panel. Clean with a vacuum cleaner that has a brush attachment or use a garden hose. Allowing dust to collect on the filter will cause the unit to lose efficiency and eventually malfunction.
2. Vacuuming dust from the return air grille and coil surface when cleaning the filter.

TROUBLESHOOTING

When trouble-shooting the indoor unit, please refer to the wiring diagram that is supplied with the equipment. It is located either on the back of the removable return air grill (CNR and WHP/WCP) or on the back of the access panel (CHP/CCP and FHP/FCP). If you are unable to locate the wiring diagram please feel free to call the factory technical service line at (800) 228-9364 and one can be faxed or mailed. Please have the full model and serial number available prior to calling.

EMI **AmericaSeries** evaporators are designed to operate with EMI **AmericaSeries** condensers. The evaporator (indoor unit) and condenser (outdoor unit) are to be independently connected to the electrical service panel on separate breakers. (See the unit name plate for the correct breaker type and size). The indoor and outdoor units are also connected to each other via a 24V interconnect wiring. **A transformer typically located in the condensing unit** provides the low volt power source for the controls. The number of low volt interconnect conductors will be three to five depending on heating options. Cooling only and cooling with electric heat units have three low volt wires. Heat pumps with electric heat require five low volt interconnect conductors. Interconnect wire should be at least 18awg. Refer to the unit wiring diagram for the interconnect diagram that matches your system.

POWER SUPPLY CHECK

When trouble shooting any EMI product, it is important to first check the rating plate for proper field voltage and breaker size. Secondly using a volt meter check the incoming power supply to see that it agrees with the rating plate. The incoming power should not exceed the nameplate voltage. Also the incoming power should not be below the minimum voltage stated on the rating plate (197V for units rated 208/230V and 104V for units rated 115V).

A check for low voltage power should also be made. By placing a voltmeter across low volt terminals "R" and "C" at the condenser there should be a reading of 24V.

After checking the condenser, a low voltage check to the indoor unit can also be made. By placing a meter across the red and brown low volt wires of the indoor unit there should also be a reading of 24V.

TEST MODE

Use of the test mode feature can aid in the functional check of the unit. It can also be a helpful tool when troubleshooting to help isolate a problem source.

CAUTION

While in test mode, all timers are eliminated. Avoid short cycling the compressor. After system checks are complete, the control must be returned to normal operation. **DO NOT LEAVE THE SYSTEM IN TEST MODE!**

To enter test mode the unit must first be in the **off state**. Next, using the unit mounted keypad depress both the **up** and **down** arrow buttons simultaneously and push the **On/Off** button in for one second. The unit is now in test mode. System function checks can now be made without having to wait for timer delays. To return to normal operation, switch the unit off again via the **On/Off** button for at least 30 seconds. When the system is switched back on, normal operation will resume.

COOLING ONLY UNITS

Cooling only units use three interconnecting, **low Volt** wires on both the indoor and outdoor units. The yellow, red and brown wires of the air handler should be connected to the corresponding yellow red and brown wires of the condenser. **A 24V transformer typically located in the condensing unit** provides low volt control power to both the air handler and condenser. The 24V-power supply can be measured by placing a meter across the red (R) and brown (C) wires. The air handler will switch on and off the condenser through the yellow (Y) wire. When the air handler is calling for cooling, 24V can be measured between terminals (wires) Y and C.

NOTE: When connecting an EMI evaporator to a non-EMI condenser, a transformer may have to be added to the system to provide 24V power to the equipment. Not all condenser manufactures supply a low Volt transformer with their condenser.

COOLING ONLY UNITS WITH ELECTRIC HEAT

Cooling only units with electric heat use three interconnecting, **low Volt** wires on both the indoor and outdoor units. The yellow, red and brown wires of the air handler should be connected to the corresponding yellow red and brown wires of the condenser. **A 24V transformer typically located in the condensing unit** provides low volt control power to both the air handler and condenser. The 24V-power supply can be measured by placing a meter across the red (R) and brown (C) wires. The air handler will switch on and off the condenser through the yellow (Y) wire. When the air handler is calling for cooling, 24V can be measured between terminals (wires) Y and C.

Units with electric heat utilize a control relay located on the circuit board in the control box. As a safety feature, an auto resetting limit switch located on the heater end plate or on the heater assembly will interrupt power to the heater should an over-heat condition occur. Each electric heat assembly is also equipped with a one time fuse link. Should electric heat temperatures rise above the auto resetting limit switch, a non-resetting, one time fuse link will open and the heater will remain off.

The following current values apply when the unit is connected to a 230V power supply. These values include fan motor current.

7KW = 31.0 AMPS
5KW = 22.3 AMPS
3KW = 13.5 AMPS

OPTIONAL HEAT PUMP WITH ELECTRIC HEAT

Heat pump units with electric heat use five interconnecting, **low Volt** wires on both the indoor and outdoor units. The yellow (Y), red (R), white (W), orange (O) and brown (C) wires of the air handler should be connected to the corresponding yellow red, white, orange and brown wires of the condenser. **A 24V transformer typically located in the condensing unit** provides low volt control power to both the air handler and condenser. With high volt power supplied to the condenser, 24V can be measured across the red (R) and brown (C) wires at all times.

COOLING

The air handler will cycle the condenser on and off through the yellow (Y) wire. To check for a condenser signal, select cooling mode on the indoor unit and place the set-point temperature below room temperature. Then, with a voltmeter check for 24 Volts across the yellow (Y) and brown (C) wires.

EMI Heat Pump systems utilize a reversing valve is that is energized in the cooling mode. The reversing-valve signal is provided through the orange (O) low volt wire of the air handler. It will remain energized constantly as long as the indoor unit remains in cooling mode. To check for 24V reversing valve voltage, place a voltmeter across the brown (C) and orange (O) wires while the indoor unit is in the cooling mode.

HEATING

This unit is designed to utilize two stage heating. The first stage being the compressor and the second is electric heat. The air handler will cycle the condenser through the yellow (Y) wire as it does in cooling however the reversing valve will not be energized. To check for a condenser signal, place the indoor unit in heating mode with the **Mode** button. Next using the **Up** arrow place the set-point temperature one degree above room temperature. Then, with a voltmeter check for 24 Volts across the yellow (Y) and brown (C) wires. The electric heat should be off at this point. Now with the **up** arrow select a set-point temperature that is more than two degrees above the room temperature. The electric heat should energize along with the 24V-compressor signal between Y and C. Check to see that the amp draw corresponds with the electric heat rating.

The following current values apply when the unit is connected to a 230V power supply. These values include indoor fan motor current.

7KW = 31.0 AMPS

5KW = 22.3 AMPS

3KW = 13.5 AMPS

Units with electric heat utilize a control relay located on the circuit board in the control box. As a safety feature, an auto resetting limit switch located on the heater end plate or on the heater assembly will interrupt power to the heater should an over-heat condition occur. Each electric heat assembly is also equipped with a one time fuse link. Should electric heat temperatures rise above the auto resetting limit switch, a non-resetting, one time fuse link will open and the heater will remain off.

ERROR CODES

Should for some reason one of the two temperature sensors become disconnected or fail, an error code will appear in the display. The control will not operate properly until the sensor is working.

E1 – Coil Sensor malfunction or disconnected. Check location **J1** on thermostat board.

E2 – Room Air Sensor malfunction or disconnected. Check location **J2** on thermostat board.

FREQUENTLY ASKED QUESTIONS

Q: The system has just been installed using an EMI indoor unit and a non-EMI condenser. There is no display and the unit will not operate.

A: When connecting an EMI evaporator to a non-EMI condenser, a transformer may have to be added to the system to provide 24V control power to the equipment. Not all condenser manufactures supply a low volt transformer with their condenser.

Q: The condenser will not start although the indoor unit appears normal. What should I do?

A: At the indoor unit, make sure that the control is in cooling and the setpoint temperature is below room temperature. Then with a volt meter check for 24V across the yellow (Y) and brown (C) wires. If 24V is present then check for wiring breaks or improper connections between the indoor and outdoor units.

A: Some EMI condensers are equipped with a manual reset high-pressure switch. It is located on the high side of the system usually on the discharge line of the compressor. To reset, simply push the red button in. If the switch was tripped there will be a “click” when it resets.

A: If the unit is equipped with a condensate pump check to see if the safety float has been tripped. This can be done by first disconnecting both ends of the float switch. Then with an Ohmmeter, check for continuity across the switch. If the switch is open then the pump is not clearing or the switch may be bad.

Q: The display on the indoor unit is blank. What should I do?

A: Check the power supply (see “Power supply check” Section). If the unit still fails to turn on via the **On/off** button then inspect the control box for any apparent wires that may have come loose during shipping. Also inspect the circuit boards for burnt components. If no obvious problem can be found then replace all circuit boards including the unit keypad. Do not attempt to trouble shoot the individual circuit boards.

Q: The display tends to flicker at times. Is this normal?

A: A small amount of flickering of the display is normal. Depending on the room lighting, flickering may be more noticeable at some times than others.

Q: How long will the fan run?

A: While the unit is in cooling or heating and auto fan mode is selected, Fan speed will be determined by the microprocessor and speed adjustment will be made according to room and setpoint temperatures. The fan will switch to **High** speed when room temperature deviates by more than two degrees from setpoint. The fan will switch to **Low** speed if the deviation is one degree. When the room temperature reaches setpoint temperature the heat/cool call is dropped. The fan will then stay on for an additional 60 sec. to purge unit of any residual energy. If **High** or **Low** is selected then the fan will operate continuous regardless of set point or room temperatures.

Q: What causes my indoor unit to freeze-up?

A: Evaporator freeze up is usually the symptom of another problem. Your unit is equipped with freeze protection to prevent freeze up from occurring. If freeze up does occur then check the following.

- Check that the freeze sensor located in the lowest part of the coil. Generally this is where freeze up will begin.
- Check that the freeze sensor inserted fully and snug in the coil fin. If not another location may need to be selected. Be careful not to insert the sensor directly into the coil tube rather insert the sensor between two tubes.
- Check the indoor air filter. It should be clean and free of dirt. A dirty filter will reduce airflow and efficiency.
- Also check that the coil is clean. If the coil is dirty then it should be cleaned using an appropriate coil cleaner or mild detergent.
- Is the equipment being operated in cooling when outdoor temperatures are below 65°F? If it is then the condenser should be fitted with low ambient control so that the proper system pressures are maintained.
- Does the system have the proper refrigerant charge? A system low on refrigerant can cause evaporator freeze-up. To check system charge you will need to contact a qualified refrigeration service technician. Refrigerant charge information can be found in EMI's Condenser IOMs.

TROUBLESHOOTING PROCEDURE *Continued*

The Test Unit Performance Data sheet below is provided for use by a qualified service professional in the event that there is a problem with the unit. In order for our Technical Service Department to better serve you, please complete

and have this information ready when calling. Make sure to include the Model Number, Serial Number, Date of Installation. Call our Technical Support Department @ 1-800-228-9364.

Test Unit Performance Data

Model Number _____
Serial Number _____

Date: _____
Technician: _____
Mode: Cooling _____

Indoor Section

Evaporator Enterin Air - DB _____
Evaporator Enterin Air - WB _____
Evaporator Leaving Air - DB _____
Evaporator Leaving Air - WB _____

Outdoor Section

Entering Air _____
Leaving Air _____
Temperature Split _____

Operating Pressures

Compressor Suction - PSIG _____
Compressor Discharge - PSIG _____

Power Input

Compressor - Volts _____
Compressor - Amps _____
OD Fan Motor - Volts _____
OD Fan Motor - Amps _____
ID Fan Motor - Volts _____
ID Fan Motor - Amps _____
Total Volts _____
Total Amps _____

Temperatures - Degrees F°

Compressor Suction _____
Compressor Discharge _____
Liquid Out Cond. _____
Liquid before Expansion _____
Suction out Evaporator _____

Capacity Calculations

DB - Temp Split at evap. _____

Notes

NOTE: Rotary compressors are critically charged systems, do not over charge. Refer to the Service and Technical Guide for charging info or call the factory. Anti-short cycle protection should be used on systems that use a conventional thermostat.

Test Summary

Compressor Superheat _____
Sub Cooling _____

ALL PRODUCT LIMITED WARRANTY

Enviromaster International LLC (EMI) warrants to the purchaser/owner that EMI products will be free from defects in material and workmanship under the normal use and maintenance for a period of twelve months for all components and sixty months on unit compressors from the date of original installation, or fifteen months for all components and sixty-three months on unit compressors from the date of manufacture, whichever comes first.

WHAT WE WILL COVER

EMI will replace any defective part returned to EMI's approved service organization with a new or rebuilt part at no charge. The replacement part assumes that unused portion of this warranty.

WHAT WE DON'T COVER

THIS WARRANTY DOES NOT INCLUDE LABOR or other costs incurred for repairing, removing, installing, shipping, servicing, or handling of either defective or replacement parts.

EMI IS NOT RESPONSIBLE FOR:

- Normal maintenance
- Damage or repairs required as a consequence of faulty installation or application by other.
- Failure to start due to voltage conditions, blown fuses, open circuit breakers, or other damages due to the inadequacy or interruption of electrical service.
- Damage or repairs needed as a consequence of any misapplication, abuse, improper servicing, unauthorized alteration, or improper operation.
- Damage as a result of floods, winds, fires, lightening, accidents, corrosive atmosphere, or other conditions beyond the control of EMI.
- Parts not supplied or designated by EMI.
- Products installed outside the United States or Canada.
- Any damages to person or property of whatever kind, direct or indirect, special or consequential, whether resulting from use or loss of use of the product.

LIMITATION OF WARRANTIES

This warranty is exclusive and in lieu of any implied warranties of merchantability and fitness for a particular purpose and all other warranties express or implied. The remedies provided for in this warranty are exclusive and shall constitute the only liabilities on the part of EMI including any statements made by any individual which shall be of no effect.

FOR SERVICE OR REPAIR:

- (1) Contact the Installer
- (2) Call the nearest Distributor
- (3) Call or write:



Comfort Where It Counts.

5780 Success Dr., Rome, NY 13440

Phone: 1-800-228-9364

FAX: 1-800-232-9364

Email: emi@enviromaster.com