

WLCG/WLHG

High-Efficiency Ductless Split System High-Wall Air Handlers

EMI  *Ductless*
Comfort Where It Counts.

Straight cool / Heat pump nominal capacities				
WLHG09	WLHG12	WLHG24		Units
9,000	12,000	18,000	23,800	Btuh
2.6	3.5	5.3	7.0	kW
Straight cooling only				
WLCG30		WLCG36		Units
28,200		33,600		Btuh
8.3		9.8		kW

Installation, Operation and Maintenance Manual



WLCG/WLHG

ECR International Inc
2201 Dwyer Ave.
Utica, NY 13501
www.enviromaster.com



innovative living™



An ISO 9001-2008 Certified Company

Contents

Contents	2	Wall Thermostat Operation	29
Read Before Proceeding	3	Controller Features	32
Verify Unit Before Installing	4	Controller Fault Conditions	33
Piston/Orifice Replacement (when required).	6	Maintenance	34
Mounting the Unit	7	Troubleshooting	36
Electrical Wiring.	9	Frequently Asked Questions.	40
Refrigerant Piping	14	Specifications and Dimensions	42
Refrigerant Processing	17	WLCG/WLHG System Options	44
Reassemble the WLCG/WLHG Cabinet	18	Test Unit Performance Data Sheet	46
Initial Start-Up.	19	EMI's Product Line	47
WLCG/WLHG Controller Overview	20	Indoor Units	47
Setting the Controller	22	Outdoor Units	47
Unit-Mounted Controller Operation	25		

IMPORTANT

Shipping damage MUST be reported to the carrier IMMEDIATELY.

Examine the exterior. Remove cover and examine piping for signs of damage.

NOTICE

The EMI series high efficiency air handler is backed by EMI and ECR International is tested, rated, and certified in accordance with AHRI Standard 210/240-2008 and UL-1995.

Due to ongoing product development, product designs and specifications may change without notice.

Please contact the factory for more information.

To the Installer

Retain this manual and warranty for future reference. Before leaving the premises, review this manual to be sure the unit has been installed correctly and run the unit for one complete cycle to make sure it functions properly.

To obtain technical service or warranty assistance during or after the installation of this unit, contact your local representative. For a local representative listing, visit our web site:

www.enviromaster.com

For further assistance call:

1-800-228-9364

When calling for assistance, please have the following information ready:

Model Number _____

Serial Number _____

Date of installation _____

Read Before Proceeding



Recognize this symbol as an indication of important safety information.



WARNING

Completely read all instructions prior to assembling, installing, operating, or repairing this product.

Inspect all parts for damage prior to installation and start-up. The EMI series high efficiency air handler must be installed **ONLY** by qualified installation personnel.



DANGER

Tampering with this unit is dangerous. Tampering voids all warranties.

DO NOT attempt to modify or change this unit in any way.



DANGER

The EMI series must:

- Be connected to a properly grounded electrical supply with the proper voltage as stated on the rating plate.
- Have proper overcurrent protection (time-delay fuse/HACR Breaker) as listed on the rating plate.

Failure to follow these instructions can result in a fire, explosion, or electrical shock causing property damage, personal injury, or death.

Safety Instructions

This manual is intended as an aid to qualified service personnel for proper installation, operation, and maintenance of the EMI series high efficiency air handler. Read these instructions thoroughly and carefully before attempting installation or operation.

Failure to follow these instructions may result in improper installation, operation, service, or maintenance, possibly resulting in fire, electrical shock, property damage, personal injury, or death.

Read all instructions before using this unit. Install or locate this unit only in accordance with these instructions. Use this unit only for its intended use as described in this manual.

Check the rating plate on the unit before installation to make certain the voltage shown is the same as the electric supply to the unit. The rating plate is located on the top panel only.

This unit must be connected only to a properly grounded electrical supply. Do not fail to properly ground this unit.

Turn off the electrical supply before servicing the unit.

Do not use the unit if it has damaged wiring, is not working properly, or has been damaged or dropped.

Verify Unit Before Installing

NOTICE

Check equipment for damage prior to installation, if damaged contact the wholesale distributor.

Product description

- The WLCG/WLHG is available as a (DX) direct expansion straight cool or heat pump.
- It offers a contemporary design in a ductless type air handler and combines attractive appearance with high efficiency conditioning for small to medium size commercial or residential spaces.
- The WLCG/WLHG is equipped with unit mounted infrared compatible controls which also supports 24V wall thermostat operation. Optional handheld remote is available.
- Heat pump models provide up to 24,000 Btuh of cooling and 20,600 Btuh of heating. Electric heat options are available for up to 5 kW of supplemental heat.
- This air handler offers ease of installation, operation, and service.
- It can be matched with EMI's:
 - Single-zone condensing units — S1CG/S1HG 09–24 and S1CG 30-36.
 - Dual-zone condensing units — S2CH/S2HH side discharge.
 - Multi-zone, top discharge condensing units — T2CG/T2HG, T3CG/T3HG, or T4CG/T4HG.
- All EMI air handlers are backed by ECR International Inc. and are tested, rated, and certified in accordance with AHRI standards 210/240-2008 and UL 1995.

Controls and components (Factory-installed or supplied)

- Large LCD Backlit Display
- Single unit-mounted control package, configurable to either unit mount or wall thermostat operation, increasing installation flexibility.

NOTICE

Unit mount control — If the control is configured for unit mount control DO NOT connect a wall thermostat to the unit. See Figure 28, Page 22.

- Unit mount control can be used in cooling only, cooling with electric heat, heat pump, or heat pump with second stage electric heat applications.
- Operational range set point temperature adjustable between 55°F (13°C) and 90°F (32°C) in one-degree increments.
- Infrared-compatible controller allows use of optional IR hand held controller.

NOTICE

Unit-mounted controls are fully functional without the handheld remote.

- Operation modes include Heat, Cool, Dry, Fan and Auto Change-over.
- Fan Operation – Auto/On. High or Low speed fan
- Fan Purge – Fan remains on for 60 seconds after Heat/Cool call is dropped for improved efficiency (Auto mode only)
- Room air sampling — Selectable time intervals ensure the fan will cycle on periodically, in Auto Fan Mode to help eliminate room temperature stratification.
- Selectable Fahrenheit (°F) or Celsius (°C) temperature scale.
- Dry mode – Operates cooling and electric heat simultaneously to remove humidity. Optional electric heat must be selected.
- Anti-Short Cycle Compressor Protection.

Verify Unit Before Installing *(continued)*

- Minimum on time for heating and cooling Helps eliminate room temperature droop and system short cycling.
- Freeze Protection – Prevents air handler freeze up.
- Test operation – Allows ease of testing after installation (all timers are reduced).
- Non-volatile back-up memory will maintain control settings for an indefinite period during a power outage. When power is restored the equipment will resume operation after a three-minute compressor time delay.
- 7-day programmable with copy feature.
- Filter change indicator: A timer feature indicates when the filter should be cleaned according to the selected time.
- Motorized supply louver with optional sweep or six stationary settings.
- Modular design – reduces parts required for control package. Deco panel, relay board, ribbon cables and microprocessor are combined into one package.
- Integral condensate pump safety-switch connection where-by the microprocessor monitors the condensate pump safety switch and displays an error code when a fault occurs. (Applies only with optional condensate pump)
- CEC (California Energy Commission) compliant
- Condensate drain pan over flow protection
- Easy access to pipe chase area from cabinet bottom allows piping connections and condensate pump installation with the unit mounted on the wall.
- Easily removable end-cap for access to control area for installation and service.
- Condensate drain pan constructed of galvanized steel (G90U), with anti-corrosion coating.
- Modular snap-in, 7-day programmable control with large backlit LCD display, a “Change filter” display feature and selectable Fahrenheit (°F), or Celsius (°C) temperature scale.

Optional Equipment

- Condensate pump (field installed only)
- 24V wall thermostat
- Electric heat with automatic reset high temperature cutout and redundant high temperature fuse link (when heat option is selected, factory installed only)
- Hand-held infrared controller.

Installer Supplied Items

- Low voltage wiring (18 AWG minimum required)
- High voltage power supply wiring
- Mounting screws and fasteners
- Condensate piping
- Refrigerant piping (if not supplied)
- Refrigerant (for interconnect charge)

Cabinet Features:

- Durable ABS plastic cabinet with a galvanized steel sub-chassis.
- Easily accessible, washable, reusable, nylon mesh filter.
- Horizontal discharge louver, constructed of high temperature ABS plastic, that can be set to oscillate, or can be parked in six pre-set positions.
- Manually adjustable vertical discharge fins.

Piston/Orifice Replacement *(when required)*

NOTICE — WLHG24 ONLY

Piston/ Orifice replacement — The factory-installed piston/orifice must be replaced on **Air-Handler / Condenser** combinations noted in table below . All other applications are to use the factory-installed orifice. To replace the orifice in the noted models use instructions and chart as follows.

Replacing the piston/orifice

1. Follow the instructions on page 9 to remove the left end cap.
2. The piston orifice (Figure 1, pg. 6) is located in the upper left corner of the unit.
3. Disassemble the orifice joint, remove the factory-installed orifice, and replace with the orifice listed in Figure 1 (supplied in the Kit Bag). Make sure o-ring is in good condition and properly installed.
4. The end cap can remain off while mounting and installing the unit.

Figure 1 Piston/orifice replacement

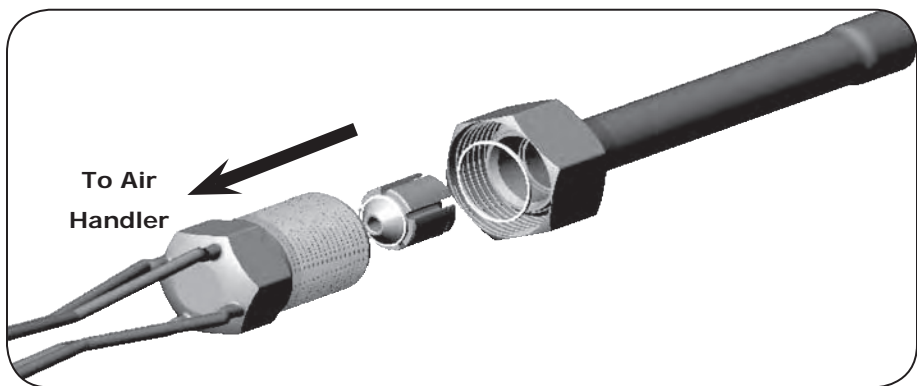

Model	Condenser	Factory-installed orifice size <i>(Inches)</i>	Replacement orifice size <i>(Inches)</i>
WLH_24	T2C/T2HG2400 T2C/T2HG4400 T3C/T3HG2240	0.054"	0.056"
WLH_24	T2C/T2HG9800 T2C/T2HG8800 T3C/T3HG9980	0.054"	0.049"
WLHA12	T2C/T2HG2400 T3C/T3HG2240 T3C/T3HG2220 T4C/T4HG9992 T4C/T4HG9922 T4C/T4HG2222	0.042"	0.044"
WLH_24	S1C/S1HG8000	0.054"	0.047"

Mounting the Unit

Before installing, consider:

- Determine the best location for mounting the unit for room air circulation.
- Locate outdoor and indoor units as close together as possible.
- Determine how power wire (high and low voltage) condensate drainage, and refrigerant piping may be run to and from the unit.
- WLCG/WLHG - Ensure that interconnect tubing is within the limits given in (Table 1, pg. 7)

Table 1 Tubing specifications

S1CG or S2CG Model	Max. Length Equivalent Feet	Max. Lift "H"	Max. Trap Height "P"	Liquid Line O.D.	Suction Line O.D.
09	50'	20'	15'	1/4"	1/2"
12	(15 m)	(6 m)	(5 m)	1/4"	1/2"
18	100'	35'	20'	3/8"	5/8"
24				3/8"	3/4"
30				3/8"	3/4"
36				3/8"	3/4"

- To ensure serviceability and proper air distribution, the unit should be positioned as close as possible to the center (left-to-right) of the wall. Minimum distance from the ceiling is stated on the template provided with the unit packaging. The cabinet left and right end caps must be accessible for removal without obstruction. (See Figure 2, Page 7.)

Site preparation

The WLCG/WLHG must be mounted plumb and level to a vertical surface to prevent unit vibration and/or unwanted noise. It is recommended that the unit be mounted directly to a

smooth surface such as Sheetrock® wallboard or similar material. If mounting to a masonry block wall, there should be a smooth barrier between the unit and the masonry block surface to absorb any potential vibration and prevent the formation of condensate on the wall.

NOTICE

If excessive noise or vibration is experienced from a unit mounted to a masonry block wall, check to ensure the unit is plumb and level. If noise or vibration persists, contact the wholesale distributor.

Figure 2 Minimum service clearances

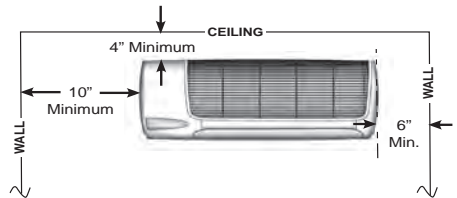
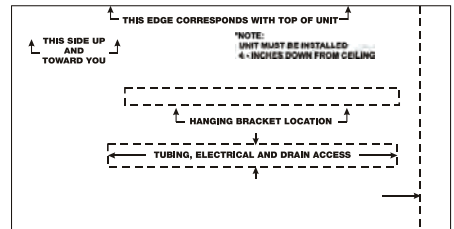

Figure 3 Mounting template



NOTICE

Piping may be roughed in before wall-board or panels are placed in new construction. PVC pipe (3" or 4" I.D.) may be used as a pipe chase.

Mounting the Unit *(continued)*

Unit Mounting Instructions

1. After determining the best location for the unit, use the cardboard template provided in the packaging (Figure 3, Page 7).
2. Mark where the piping, electrical wiring and condensate drain should penetrate the wall.
3. Determine the appropriate hole size and cut through the wall.
4. Use the supplied wall bracket. For shipping purposes, the wall bracket is fastened to the back of the unit.
5. Secure the bracket to the wall with the appropriate screws (for wood) or anchors (for masonry). Ensure the bracket is mounted in a manner that will support the weight of the unit (Figure 4, Page 8).
6. To mount the unit to the bracket, align the mounting slot on the back of the unit over the bracket and make certain it fits properly (Figure 5, Page 8).



WARNING

Replace all panels after installation or servicing. Panels must remain on the unit at all times while powered and in operation.

Figure 4 Wall hanging bracket

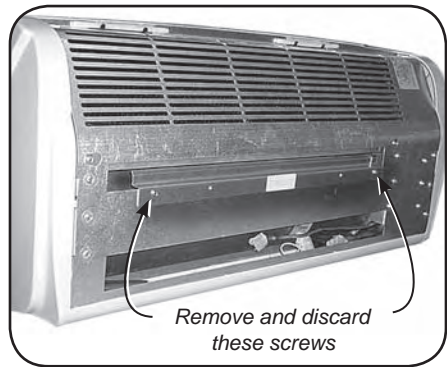

*Remove and discard
these screws*

NOTICE

The wall hanging bracket is not located in the center of the unit.

Figure 5 Mounting to wall bracket

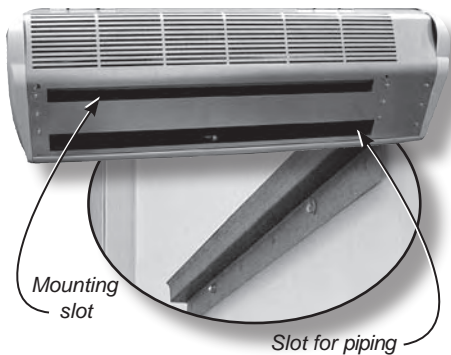

*Mounting
slot*

Slot for piping

Electrical Wiring

NOTICE

All electrical wiring must be run according to NEC and local codes.

Site preparation for wiring

WARNING

Electrical shock hazard — Make sure the power is off before proceeding.

1. Check the unit rating plate for minimum circuit ampacity and breaker or time delay fuse size. Use only HACR type breakers. Select the proper wire for the ampacity rating.
2. Each unit must have a separate branch circuit protected by a time delay fuse or breaker. Refer to the unit rating plate for the proper wire and breaker or time delay fuse size.
3. Inspect the existing wiring for any defects such as cut or frayed wires. Replace if any such wiring is found.
4. The left end cap of the unit needs to be removed to access wiring diagram and electrical wiring. This requires removal of three screws (Figure 6, Page 9 and Figure 7, Page 9).
5. Rotate louver down to expose the third screw (Figure 8, Page 9).
6. Once the screws are removed, slide the left end cap off to expose control box and locate the wiring diagram on the inside of the end cap.

NOTICE

On units rated 208/230V, the primary side of the transformer is factory wired for 230V. For a 208V power supply, the transformer tap must be changed from orange to red. Refer to the wiring diagram located on the inside of the left end cap of the unit.

Figure 6 Before removing end cap

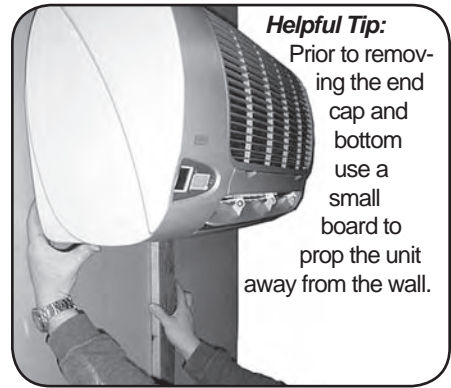

Figure 7 Removing end cap

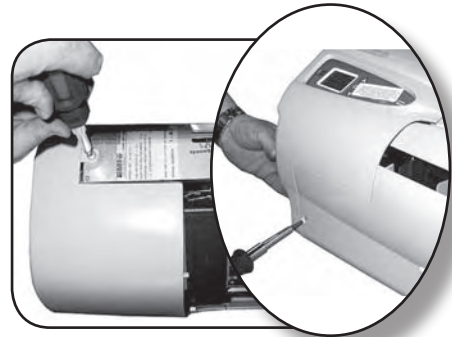

Figure 8 Rotate louver down to expose screw



Electrical Wiring *(continued)*

Connect wiring

1. To access High and Low volt wiring remove the screw on the front of the control box. (Figure 9, pg. 10)

High voltage electrical wiring

1. Refer to the wiring diagram to connect the power wire to Black L1 and the other wire to Red or White (115V) L2 at the power connector location. (Figure 10, pg. 10)
2. Connect the ground wire to the ground lug or lead at the same location in the control box.



WARNING

Terminate ALL unused wires with a wire nut or crimp connector.

Figure 9 Wiring diagram location

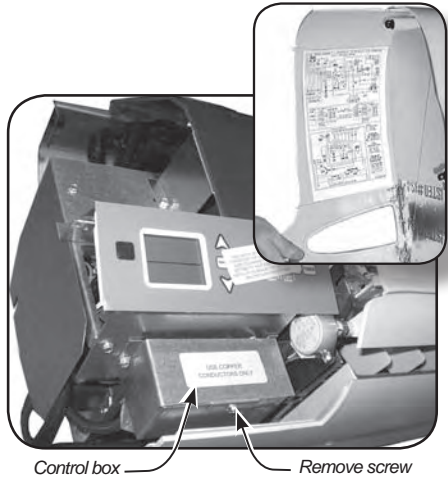

Low voltage electrical wiring

(for unit-mounted controls)

1. **The 24V control transformer is located in the air handler.** This provides low Volt control power to both the air handler and condenser. Depending on the models selected, the low volt interconnect control wiring may be effected. (Figure 10, pg. 10)

NOTICE

All low voltage interconnect wiring must be at least 18 AWG.

Figure 10 Wiring connections

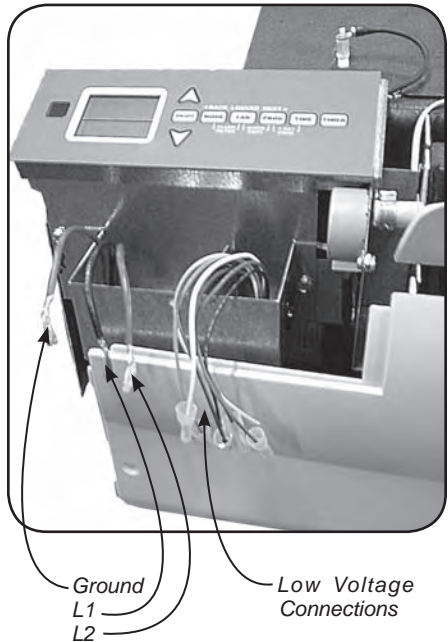

Electrical Wiring (continued)

Units with or without heat

NOTICE

All low voltage interconnect wiring must be at least 18 AWG.

Cooling-only

Cooling only units utilize two low volt interconnecting wires between the indoor and outdoor units.

Wires designated “Y” (yellow) and “C” (brown) of the air handler should be connected to the corresponding “Y” (yellow) and “C” (brown) wires or terminals of the condenser (Figure 11, Page 11).

Other wires or terminals such as “R” (red) or “O” (orange) may not be needed and should be protected by a wire nut from making contact with the junction box or other metal surfaces.

Heat pump connection

Heat Pump Connection: In addition to the “Y” and “C” connections required for cooling, heat pumps require a reversing valve control wire “O” (orange) that is energized in the cooling mode.

If the indoor unit has an electric heater, then a “W” (white) wire connection will also be needed to energize the indoor electric heat. If a wall thermostat is used.

Heat pumps models require an “R” connection between the indoor and outdoor unit to provide power to the defrost control board in the condenser (Figure 12, Page 11).

Figure 11 Unit-mounted controls — cooling only

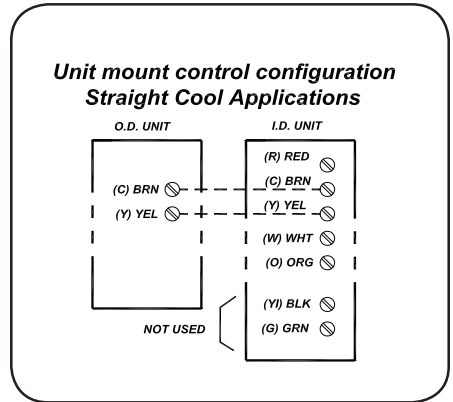
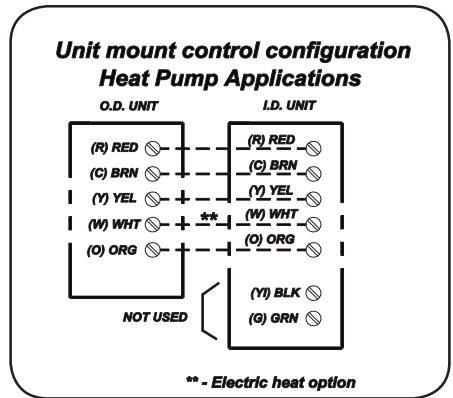

Figure 12 Unit-mounted controls — heat pump connection, two-stage heating



Electrical Wiring *(continued)*

Wall thermostat controls

For remote wall mounted thermostat layout see - (Figure 13, pg. 12)

NOTICE

All low voltage interconnect wiring must be at least 18 AWG.

NOTICE

Unit mount control — If the control is configured for unit mount control DO NOT connect a wall thermostat to the unit.

The 24V control transformer is located in the air handler unit. This provides low volt control power to both the air handler and condenser. Depending on the models selected, the interconnect control wiring may be effected.

NOTICE

For wall thermostat mode, the key pad will have limited operation (see Sequence of Operation — Wall-mounted thermostat, page 29).

Choosing a remote wall-mounted thermostat

See page 29 for wall thermostat selection information.

Depending on the thermostat required or selected, air handlers may utilize four to six low volt interconnecting wires between the indoor unit, thermostat and outdoor unit.

Some thermostats do not require the use of the “C” (brown) connection. In this case, ensure that any unused wires are insulated with a wire nut to prevent them from making contact with the junction box or other metal surfaces.

Figure 13 Wall-mounted thermostat configuration — cooling only

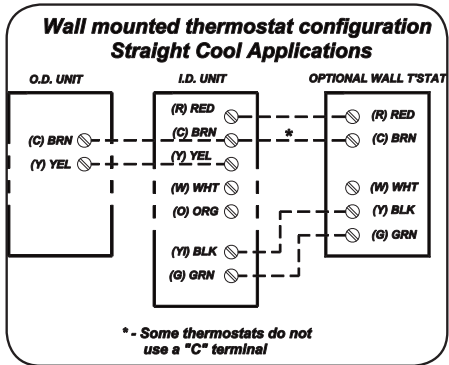

Electrical Wiring (continued)

Electric heat applications

(Figure 14, Page 13)

If the indoor unit has electric heat then a “W” connection is required between the thermostat and indoor unit.

Some thermostats do not require the use of the “C” (brown) connection.

Heat pump applications

(Figure 15, Page 13)

Heat pump operation requires the connection of the “O” (orange) terminal from the outdoor unit to the thermostat.

The reversing valve is energized in the cooling mode for EMI models SHG heat pump condensers.

NOTICE

Heat pumps only: Two-stage heating requires the combination of a heat pump condenser and an indoor unit that is equipped with an electric strip heater. The indoor electric heater will energize as the second stage heat source (the temperature is dependent on the thermostat selected) and also during the defrost mode for all heat pump models.

Finishing

Ensure that any unused wires are insulated with a wire nut to prevent contact with the junction box or other metal surfaces.

Once certain all electrical connections are made replace control box cover.

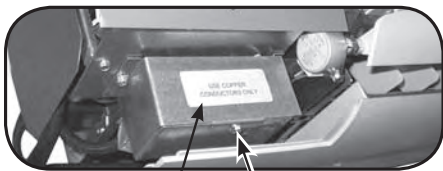

Control box — Replace screw

Figure 14 Wall-mounted thermostat configuration — cooling + electric heat

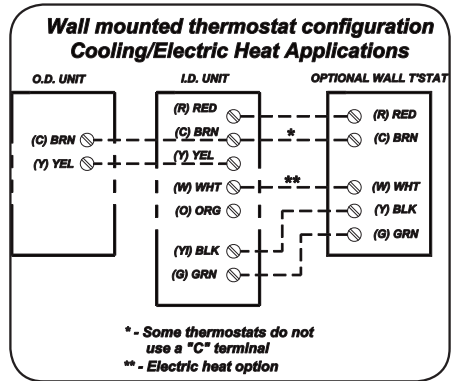
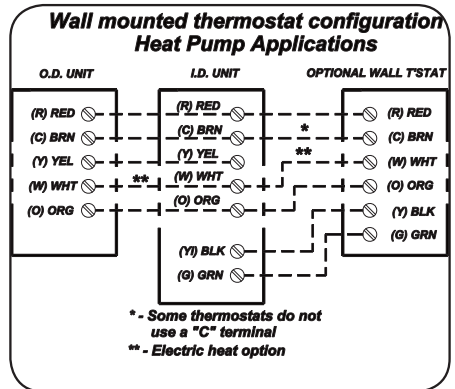

Figure 15 Wall-mounted thermostat configuration — cooling + heat pump



Refrigerant Piping

CAUTION

- Avoid piping on wet and rainy days.
- Use only clean, refrigeration-grade copper tubing.
- Use tubing benders to guard against kinking.
- Be certain no burrs remain on the fittings.
- Cap ends of lines until ready for connections. Be certain that plastic end caps remain in place when inserting through wall openings.
- Insulate the suction line.
- Isolate tubing from transmitting vibration to the building or unit and avoid contact with sharp edges.
- Wrap refrigeration valves with a wet rag “heat sink” to protect valves while brazing. (See Figure 14, Page 15.)
- DO NOT use a suction line size larger than the condenser service valve connection. This can harm the compressor. Install a reducer, when used, only on the inside connection.

Preparing for piping

1. With the unit mounted and leveled per instructions beginning on page 7.
2. Leave the left end cap off of the unit to allow removal of the bottom panel.
3. Remove the Phillips-heads screws on the bottom of the unit and remove the bottom panel (Figure 16, Page 14).
4. See (Figure 17, Page 14) for locations of the piping connections in the WLCG/WLHG unit.

Figure 16 Removing bottom panel

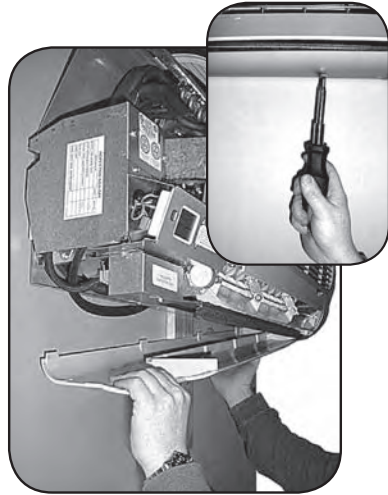
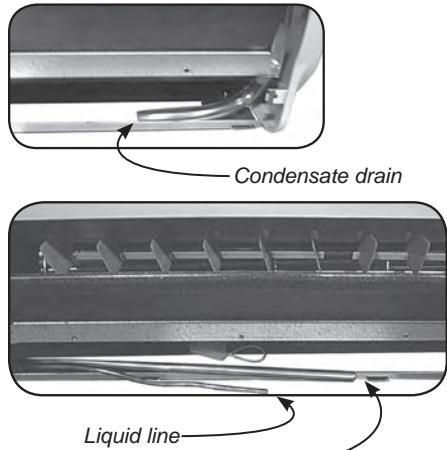

Figure 17 Piping connections at unit



Suction line
 (When a reducing bushing is required, install only here, at the indoor suction-line connection.)

Refrigerant Piping *(continued)*

NOTICE

The WLCG/WLHG is equipped with a Flo Rater piston expansion device or TXV. Connections are sweat type.

Line sizing

1. Size lines per (Table 7, Page 43).
2. The suction line size must match the condenser service valve connection.
 - a. When matching the WLHG24 with an 18,000-Btuh condenser, you must use a 5/8-inch suction line, with a reducer installed as shown in (Figure 17, Page 14).

Refrigerant piping

1. Clean the ends of tubing and insert into fittings (Figure 18 page 15).
2. Before brazing (Figure 19 page 15):
 - a. Protect valves by wrapping with a wet rag “heat sink” before brazing.
 - b. Use a shield to protect the paint as shown. (The shield can be made from scrap metal.)
3. Braze tubing into fittings, using a continuous nitrogen purge.
4. The suction line must be insulated the entire length with closed cell, foam tube insulation.
5. Do not insulate the liquid line.
6. Connect the outdoor unit according to the instructions supplied with unit.
7. All horizontal piping runs must be level and without dips to trap the oil.

Figure 18 Clean ends of tubing

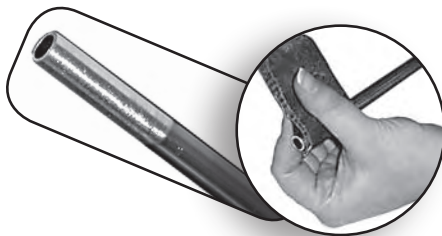
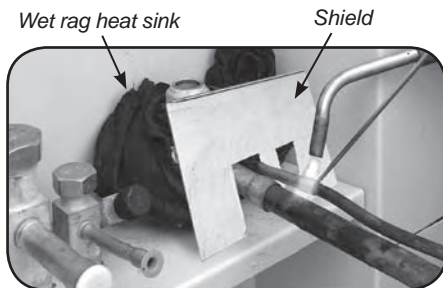

Figure 19 Place wet rag “heat shield” over valves plus a sheet metal shield to protect paint



CAUTION

Pressure test all field installed piping with nitrogen. Using a suitable vacuum pump, evacuate the tubing and indoor unit to 500 microns or less, with service valves remaining front seated (closed).

Refrigerant Piping *(continued)*

Refrigerant processing

1. Attach manifold set (Figure 20 page 16).
2. Evacuate line to 500 microns or less to ensure all moisture has been removed and there are no leaks.
3. Once certain of a good evacuation and leak free joints, back-seat the valves (counter-clockwise) to open and allow factory charge to fill lines and indoor unit (Figure 21, Page 16).

NOTICE

Refer to refrigerant charge table for specified charge.

4. Use only R410A refrigerant. Add and remove only liquid, never vapor.
5. Charge to proper weight, charge based on feet of interconnect (Figure 22, Page 16). See tables on page 17.



CAUTION

Refer to the charts in the condenser manual to “fine tune” the refrigerant charge.

WLCG30 and WLCG36 utilize a TXV (thermo expansion valve), which should be set at 15°F.



CAUTION

Charging should be done with a dial-charge or weighed in with a scale.



WARNING

It is illegal to discharge refrigerant into the atmosphere. Use proper reclaiming methods & equipment when installing or servicing this unit.

Figure 20 Manifold set connections at unit

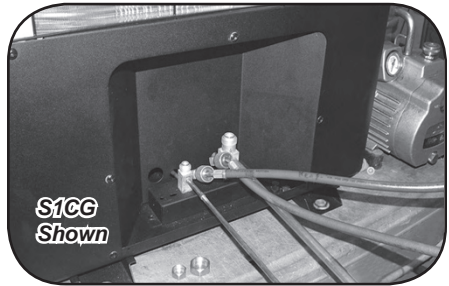
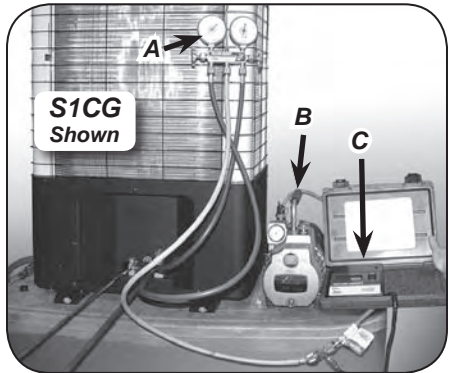
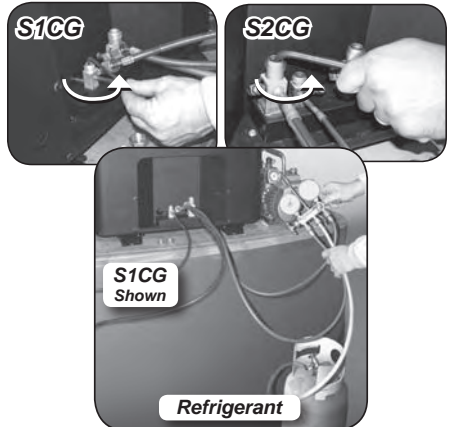

Figure 21 Manifold set up for evacuation



- A** Manifold gage
- B** Vacuum pump
- C** Micron gage

Figure 22 Charging the unit



Refrigerant Processing

NOTICE – to find charge adjustment

1. To find the charge adjustment and system charge for any air handler and tubing length:

$$\text{Line Adjustment} = (\text{Line Charge}/\text{FT}) \times \text{Line Length}$$

$$\text{System Total} = \text{Factory Charge} + \text{Line Adjustment}$$
2. Round to the nearest ounce and allow for gauges and hoses.

Table 2 S1CG/S1HG, S2CG/S2HG and top discharge R410A refrigerant charge table

Condenser	Wall Unit pairing	Line charge per foot	Factory charge	Top discharge, Multi-zone			
				Circuit capacity	Wall Unit Paring	Line charge per foot	Factory charge
S1CG9	WLHG09	.25 oz./ft (23 g/m)	39.5 oz. (1119 g)				
S1CG2	WLHG12	.25 oz./ft (23 g/m)	33.75 oz. (956 g)				
S1CG8	WLHG24	.64 oz./ft (59 g/m)	65.25 oz. (1764 g)	9,000 Btuh	WLHG09	.25 oz./ft (23 g/m)	46.5 oz. (1318 g)
S1CG4	WLHG24	.64 oz./ft (59 g/m)	63.0 oz. (1786 g)	12,000 Btuh	WLHG12	.25 oz./ft (23 g/m)	45.25 oz. (1282 g)
S1CG3	WLCG30	.64 oz./ft (59 g/m)	97.5 oz. (2764 g)	18,000 Btuh	WLHG24	.64 oz./ft (59 g/m)	96.75 oz. (2742 g)
S1CG6	WLCG36	.64 oz./ft (59 g/m)	80.0 oz. (2267 g)	24,000 Btuh	WLHG24	.64 oz./ft (59 g/m)	78.5 oz. (2225 g)
S1HG9	WLHG09	.25 oz./ft (23 g/m)	51.52 oz. (1460 g)	Side Discharge Multi-zone			
S1HG2	WLHG12	.25 oz./ft (23 g/m)	45.75 oz. (1296 g)	Circuit capacity	Wall Unit Paring	Line charge per foot	Factory charge
S1HG8	WLHG24	.64 oz./ft (59 g/m)	63.0 oz. (1786 g)	9,000	WLHG09	.25 oz./ft (23 g/m)	44 oz. (1247 g)
S1HG4	WLHG24	.64 oz./ft (59 g/m)	60.75 oz. (1722 g)	12,000	WLHG12	.25 oz./ft (23 g/m)	39 oz. (1105 g)

Reassemble the WLCG/WLHG Cabinet

CAUTION

Verify the system is leak-free and all piping has been properly installed before reassembling the cabinet.

Reassemble the cabinet

Figure 23, Page 18

1. Replace the bottom panel.
2. Fasten the right end cap first using the Phillips head screw.
3. Replace and tighten the remaining screws across the bottom panel.

Figure 23 Replace bottom panel

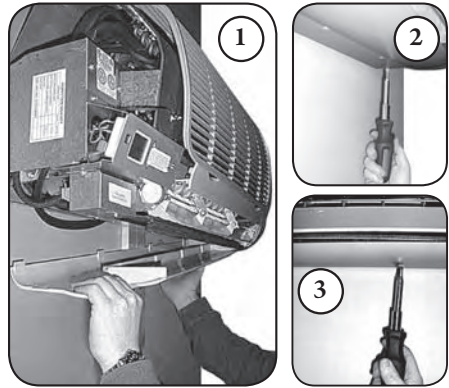

Figure 24, Page 18

4. Replace the left end cap.
5. Once end cap is properly seated, tighten the screw on the right.
6. Tighten the bottom end cap screw.

Figure 24 Replace left end cap

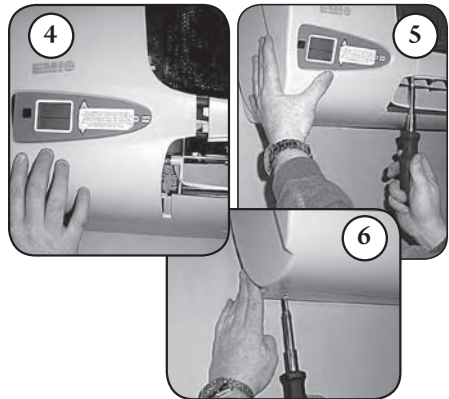
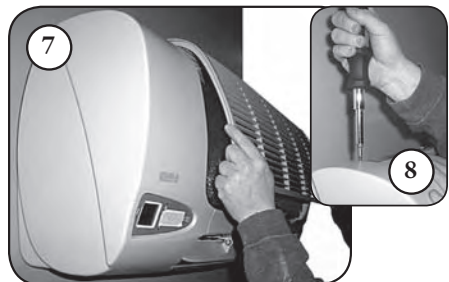

Figure 25, Page 18

7. Replace the grille.
8. Tighten the top screw on the left end cap.

Figure 25 Replace grille



Initial Start-Up

NOTICE

Operation of the unit depends on the room temperature. It may be necessary to warm the room before testing the unit's cooling abilities.

Before starting the unit

NOTICE

Check the outdoor unit's start-up instructions for specific requirements and procedures.

1. Remove any tools or other obstructions.
2. Be sure the filter is in place.
3. Verify that the unit is level and plumb.
4. Separate any refrigerant lines that contact each other.
5. Replace the cabinet end cap and the grille front of the unit.
6. Test each power and circuit connection before powering up the system.
7. Configure the controller per Figure 28, Page 22.
8. Make set-up adjustments as needed using Figure 29, Page 23. Use Test mode if desired to reduce start-up time.
9. Use the unit-mounted electronic controller to start the system. (Set remote thermostat to OFF in the controller configuration, Figure 28, Page 22.)
10. Connect wall thermostat wiring (if used) after initial start-up. (This requires re-setting the remote thermostat option to the "ON" configuration, Figure 28, Page 22.)
11. Cycle the unit several times in each mode to ensure the system and components are operating correctly.

Unit-mounted controller operation

Select Remote Thermostat OFF in the configuration. For operating details, see information beginning on page 25.

The EMI Series controller can operate the unit in cooling, heating (when equipped) or auto changeover mode. Setpoint temperature can be either manually set or allowed to follow pre-programmed (7-day) settings. (See Figure 29, Page 23) for more information.

The controller provides diagnostics with announcement and includes sensors to prevent short cycling and other benefits as explained on page 32.

Adjust and configure the unit using the keypad (see Figure 26, Page 20).

The unit can be operated with either the keypad or the optional infrared remote control (Figure 27, Page 21).

Before operating the unit, use the information in (Figure 28, Page 22) and (Figure 29, Page 23) to configure and set up the controller.

Wall thermostat operation

Select Remote Thermostat ON in the configuration. (Figure 28, pg. 22)

See page 29 for setup and operation when using a wall thermostat.

The unit must be configured for wall thermostat operation as described in (Figure 28, Page 22).

WLCG/WLHG Controller Overview

Figure 26 Ductless Series unit-mounted controller — chassis-mounted keypad/display



ON/OFF	Press to turn on or off.
MODE	Press to change operating mode — toggles between Cool, Heat, Auto changeover, Dry or Fan modes.
FAN	Press briefly to toggle fan speed between High, Low and Auto. Press and hold for three seconds to set louver position (see Figure 29, Page 23).
PROG	During operation — press to enter/exit pre-programmed mode (see Figure 29, Page 23). During configuration — press to move backwards in menus.
TIME	With the unit ON, press and hold 3 seconds to enter time set mode — sets current time of day.
TIMER	With the unit ON, press to enter or exit sleep timer mode. In sleep timer mode, the unit will operate for 30 minutes, then turn OFF. The display will show TIMER.
	During operation — use to increase or decrease the setpoint temperature. During configuration, setup, etc. — use to increase or decrease the setting. Holding the button will cause rapid change.
MODE + FAN	FILTER CHECK reset — Press both buttons and hold for 3 seconds to clear FILTER CHECK (see Figure 28, Page 22).
FAN + PROG	QUICK COPY — Press both buttons and hold for 3 seconds during 7-day programming to copy the current day's settings to all days (see Figure 29, Page 23).
PROG + TIME	7-DAY PROGRAMMING — Press both buttons and hold for 3 seconds to enter 7-day programming mode (see Figure 29, Page 23).
MODE + PROG	CONFIGURATION MODE — Press both buttons and hold for 10 seconds to enter configuration mode (see Figure 28, Page 22).
ON/OFF + PROG + TIME	TEST MODE — Press all three buttons and hold for 3 seconds to enter test mode (see Figure 29, Page 23).

WLCG/WLHG Controller Overview *(continued)*

Figure 27 WLCG/WLHG controller — infrared remote control — *optional only*

	POWER	Press to turn unit on or off.
	▲ ▼	Use to increase (+) or decrease (-) the setpoint temperature. Holding the button will cause rapid change.
	DRY	DRY MODE — Press to enter dry mode (see page 27).
	FAN	FAN MODE — Press to enter fan-only mode (no cooling or heating).
	AUTO	AUTO CHANGEOVER MODE — Press to enter auto changeover — cooling/heating (see Figure 28, Page 22).
	FAN SPEED	Press to toggle the fan between HIGH, LOW and AUTO.
	HEAT	HEAT MODE — Press to enter heat mode (see Figure 28, Page 22).
	COOL	COOL MODE — Press to enter cool mode (see Figure 28, Page 22).
	LOUVER	Press to toggle between louver positions (see Figure 29, Page 23).

Setting the Controller

Figure 28 Configuration settings for WLCG/WLHG (available only using unit-mounted keypad)

Setting Item	Display	Possible Value (flashing)	Factory Settings	Overview	
To access: While in OFF mode, press MODE and PROG together for 10 seconds, repeat to exit; automatically exits after 20 seconds idle					
Temperature scale	01 F-C	F C	Fahrenheit Celsius	F	Select temperature scale for display and operating settings.
Remote thermostat	02 r-t	ON OFF	Uses wall thermostat Uses internal temperature controller	OFF	The unit can operate with its internal temperature controller or by a wall thermostat. Make sure this setting matches the installation — it must be set OFF for self-controlled operation. When set to ON, the wall thermostat controls most functions. Only the FAN and TIME buttons on the unit are operational (reset from FILTER CHECK can still be done with the MODE and FAN buttons).
Heat source	03 HEAT	ON OFF	Available Not available	See Note 3	Set this to ON if the unit is equipped with the electric heater option or matched with a heat pump condenser. The electric heater is required for DRY mode operation and for automatic changeover operation.
Heat pump <i>(see Note 1)</i>	04 H-P	ON OFF	Available Not available	OFF	Set this to ON if the unit is built for heat pump operation and connected to an appropriate compressor unit.
Auto changeover differential <i>(see Note 2)</i>	05 d-b	x	2° – 6°	2°	Auto changeover automatically operates the unit in heating or cooling based on room temperature versus setpoint. This setting is the dead band temperature: <ul style="list-style-type: none"> • Cooling is on while room temperature is at setpoint PLUS dead band. • Heating is on while room temperature is at setpoint MINUS dead band. • Example: setpoint = 68°F; dead band is 3°F — cooling is on with room temperature at or above 71°F — heating is on with room temperature at or below 65°F.
Check filter time	06 F.Lt	2 5 7 10 12	250 hours 500 hours 750 hours 1000 hours 1250 hours	10	Set this time for automatic notice of time to change the filter. At the end of the time period, the control will display a FILTER CHECK warning. This warning will also appear if four coil freeze-ups should occur in a 24-hour period. Reset the warning, restarting the time period, by pressing MODE and FAN buttons together for 3 seconds.
Room air sampling	07 Ar	OFF 5 10 15	Disabled 5 minutes 10 minutes 15 minutes	15	During stand-by periods, room air sampling causes the fan to cycle on for 60 sec at the time interval specified here. This ensures the unit's temperature sensor will see an accurate sampling of room air (avoiding comfort problems due to stratification).
Annunciation	08 b-P	ON OFF	Enabled Disabled	ON	Set to ON for the unit to emit a beep signal when any button is pushed with the unit on, and when the ON/OFF button is pushed with the unit off.
LCD backlight	09 LtE	ON In OFF	Always ON Intermittent Always OFF	In	This allows turning off the LCD backlight except when needed. Set to OFF for the backlight to be off at all times or to ON for the backlight to be on constantly, even with the unit off. Set to intermittent for the backlight to come on for 10 seconds when any button is pushed while the unit is on, and when the ON/OFF button is pushed while the unit is off.

Note 1 Setting 04, Heat pump, is SKIPPED if setting 03, Heat source, is OFF.

Note 2 Setting 05, Auto changeover, is SKIPPED if setting 03, Heat source, is OFF or if Setting 02, Remote thermostat, is ON.

Note 3 Factory setting is ON if electric heat is installed in unit, or OFF if electric heat is not installed

Setting the Controller *(continued)*

Figure 29 Setup options for WLCG/WLHG high-wall air handlers

Item	Display	Possible Value (flashing)	Factory Settings	Overview
Louver position	Lou	01, 02, 03, 04, 05, 06, or Auto	01	<p>The louver is closed when the fan is off.</p> <p>If set to AUTO, the louver oscillates through all positions during fan operation, then closes.</p> <p>The other settings are six fixed positions for the louver — the louver moves to this position and remains there during fan operation, then closes.</p>
	<p>To access using unit-mounted keypad: Press and hold FAN button for 10 seconds; use arrow keys to select position; save selection by pressing FAN again momentarily or let idle for 10 seconds to save and exit automatically</p> <p>To access using handheld remote: Press LOUVER button to access; each additional press of the LOUVER button changes the selection one position; stop pressing when selection is reached, or leave idle for 10 seconds to save and exit automatically</p>			

Item	Display	Overview
Test mode	tSt	<p>Use this mode to reduce cycle times by 1/4 allowing quicker operational testing.</p> <p>⚠ CAUTION — DO NOT cycle the unit quickly while in test mode — the compressor can be damaged by rapid cycling.</p>
	<p>Access using unit-mounted keypad only: Turn the unit off with the ON/OFF button; press and hold ON/OFF, PROG and TIME simultaneously for three seconds; exit test mode by repeating the button press or by cycling the main power to the unit off, then on again.</p>	

Item	Setting	Values	Overview
7-Day programming <i>(use Table 4, Page 24 to record settings)</i>	Day of week	Mon, Tue, Wed, Thu, Fri, Sat, Sun	The louver is closed when the fan is off.
	Period of day	Morning Day Evening Night	The periods provide four time settings to initiate a change in cooling/heating setpoints. They allow adjustments for setback (such as night setback, daytime setback and occupied settings for residential applications). Set the hour/minute for each time as well as the cooling and heating setpoints below.
	Hour	0–12 a 0–12 p	Set the time to begin the period.
	Minute	0–59	
	Cooling setpoint	55–90°F (13–32°C)	The unit will default to this setpoint when set to Cooling in pre-programmed run mode.
	Heating setpoint	55–90°F (13–32°C)	The unit will default to this setpoint when set to Heating in pre-programmed run mode.
	Auto setpoint	55–90°F (13–32°C)	The unit will default to this setpoint when set to Auto in pre-programmed run mode. (The unit will auto changeover between heating and cooling.)
	<p>Access using unit-mounted keypad only: Press and hold PROG and TIME buttons simultaneously for 3 seconds; use arrow keys to select position; save selection and exit by repeating the button press or leave idle for 20 seconds to save and exit automatically</p> <p>Navigating through settings: Press PROG to move to the next setting or MODE to move to the previous setting; to change values, use the arrow keys; when value is reached move to the next setting using the PROG or MODE button; values are stored on exit from programming mode</p>		

Setting the Controller *(continued)*

Table 3 Programming schedule (when using 7-day programming)

	Morning			Day			Evening			Night		
	Auto	Heat	Cool	Auto	Heat	Cool	Auto	Heat	Cool	Auto	Heat	Cool
Monday	Time	:		Time	:		Time	:		Time	:	
	Temp			Temp			Temp			Temp		
Tuesday	Time	:		Time	:		Time	:		Time	:	
	Temp			Temp			Temp			Temp		
Wednesday	Time	:		Time	:		Time	:		Time	:	
	Temp			Temp			Temp			Temp		
Thursday	Time	:		Time	:		Time	:		Time	:	
	Temp			Temp			Temp			Temp		
Friday	Time	:		Time	:		Time	:		Time	:	
	Temp			Temp			Temp			Temp		
Saturday	Time	:		Time	:		Time	:		Time	:	
	Temp			Temp			Temp			Temp		
Sunday	Time	:		Time	:		Time	:		Time	:	
	Temp			Temp			Temp			Temp		

To copy the settings from any day to the entire week:

- 1) Select the day to be copied.
- 2) Simultaneously press the **"FAN"** and **"PROG"** buttons for three seconds.

Unit-Mounted Controller Operation

NOTICE

When power is first applied to the control or after a power outage there is a three minute delay before the compressor or electric heat will energize. This is to protect the unit from short cycling due to loss of power.

NOTICE

The controller must be configured with **Remote Thermostat OFF** to operate using the unit-mounted controller. See (Figure 28, Page 22) for details. (Remote Thermostat ON means the unit will be controlled by a wall thermostat.)

ON/OFF

Pressing the ON/OFF button once will switch the unit either on or off.

- In OFF mode, the LCD will display the time of day and day of the week.
- In ON mode the LCD display will also display the room temperature and the mode of operation:
 - **Cool**
 - **Heat**
 - **Auto** (*Auto changeover — cool/heat*)
 - **Dry**
 - **Fan**
- While in ON mode, the set point temperature will display momentarily with the push of any button except the ON/OFF button.

MODES

The MODE button allows the selection of the mode of operation, Cool, Heat, Auto changeover (ACO), Dry or Fan mode. In Fan mode either HIGH or LOW will be displayed on the LCD. See (Figure 28, Page 22).

FAN operation

The indoor unit utilizes a two-speed motor with three operational fan modes.

The FAN button will allow the selection of the desired fan setting in all modes except Dry mode.

In Dry mode, the fan will operate constantly at low speed.

- The LCD will indicate fan speed selection.
- When the unit is in Dry mode the fan speed will remain constant at Low speed.
- While the unit is in Fan mode, Auto is by-passed and only High or Low speeds are available.

Fan speeds

High and **Low** are constant fan settings. The fan will operate continuous regardless of set point or room temperatures. **Auto** mode is for automatic cycling fan operation.

Auto fan mode can only be selected if the unit is in Heat, Cool or Auto changeover modes.

- In Auto Fan mode the fan will cycle with the call for Heat or Cool.
- Fan speed will be determined by the microprocessor and speed adjustment will be made according to room and setpoint temperatures.
- The fan will switch to High speed when room temperature deviates by more than two degrees from setpoint.
- The fan will switch to Low speed if the deviation is one degree or less.
- When the room temperature reaches setpoint temperature the heat/cool call will then be dropped.
- The fan will stay on for an additional 60 seconds to purge unit of any residual energy.

Unit-Mounted Controller Operation *(continued)*

Room air sampling

If the room air sampling feature has been enabled in configuration (see Figure 28, Page 22.), then after the fan has been off for the selected time, it will cycle on for a 60 second cycle.

- The unit will circulate room air for 60 seconds to remove any temperature stratification by the unit so the microprocessor can determine an accurate room temperature.
- After the 60 second fan cycle time has elapsed, and if the setpoint temperature remains satisfied, the fan will cycle off.

COOL mode

For cooling operation first turn the unit on via the ON/OFF button.

- Select Cool mode via the MODE button.
- The room temperature and set point temperature will be displayed.
- The setpoint temperature can be changed with each successive press of the Up or Down arrow buttons or by holding the button in. Holding the button in will change the temperature rapidly.

Place the setpoint temperature below the room temperature.

- The compressor will start and cooling will continue for a minimum of two minutes and as long as the setpoint remains below room temperature.
- Once the room temperature is satisfied for at least 60 seconds and the two-minute minimum run time has elapsed the compressor will cycle off.
- The fan will operate as described in Fan operation, page 25.

NOTICE

Once the compressor is switched off, or after a power outage, there is a three-minute delay before the compressor will re-start.

Optional ELECTRIC HEAT operation

(Non heat pump condenser units only and WLCG)

For operation with electric heat the control must first be configured properly — heat source ON, heat pump OFF. See (Figure 28, Page 22).

For electric heat operation, first turn the unit on via the ON/OFF button.

- Select Heat mode via the MODE button.
- The room temperature and setpoint temperature will be displayed.
- Press either the Up or Down arrow buttons to change the setpoint temperature.
- The setpoint temperature will change by one degree with each successive press of the Up or Down arrow buttons. Holding the button in will change the temperature rapidly.

Place the setpoint temperature above room temperature.

- The electric heat will energize and heating will continue as long as the setpoint remains above room temperature.
- When the room temperature has been satisfied for at least 60 seconds and the two minute minimum on time has expired, the electric heat will switch off.
- The fan will operate as described in Fan operation, page 25.

Optional HEAT PUMP WITH ELECTRIC HEAT *(Two-stage heating)*

For heat pump operation with electric heat the control must first be configured properly

Unit-Mounted Controller Operation *(continued)*

(Heat source ON, heat pump ON). See (Figure 28, Page 22).

For heat pump operation with backup electric heat, first turn the unit on via the ON/OFF button.

- Select Heat mode via the Mode button.
- The room temperature and setpoint temperature will be displayed.
- Press either the Up or Down arrow buttons to change the setpoint temperature.
- The setpoint temperature will change by one degree with each successive press of the Up or Down arrow buttons. Holding the button in will change the temperature rapidly.

Place the setpoint temperature above the room temperature by one degree.

- The compressor will start and heating will continue for a minimum of two minutes and as long as the setpoint remains above room temperature.
- When the room temperature has been satisfied for at least 60 seconds and the minimum on time has elapsed, the compressor will switch off.
- The fan will operate as described in Fan operation, page 25.

Place the setpoint temperature above the room temperature by at least two degrees.

- The compressor will start and, the electric heat will also energize after a 30 second delay, thus two-stage heating.
- The electric heat will run for a minimum of two minutes and until the deviation between room temperature and setpoint temperature is less than two degrees.
- At that time the electric heat will switch off and the heat pump (compressor) will take over the heating demand.
- The electric heater will not re-start until a three minute delay has elapsed.
- Once the room temperature is satisfied and the two-minute minimum run time has elapsed, the compressor will cycle off.

- The compressor will not re-start until a three minute delay has elapsed.
- The fan will operate as described in Fan operation, page 25.

DRY mode

For Dry mode operation the unit must have an electric heater. Also the control must first be configured properly (Heat source ON). See (Figure 28, Page 22).

Dry mode will remove humidity from the air while maintaining setpoint temperature.

- This is done by energizing the compressor in cooling along with the electric heater.
- Dry mode will not maintain a specific humidity level.
- The unit must be equipped with an optional electric heat element.

For Dry Mode operation, first turn the unit on via the ON/OFF button.

- Select Dry mode via the MODE button.
- The room temperature and setpoint temperature will be displayed.
- Press either the Up or Down arrow buttons to change the setpoint temperature.
- The setpoint temperature will change by one degree with each successive press of the Up or Down arrow buttons. Holding the button in will change the temperature rapidly.

Place the setpoint temperature at a desired room temperature.

- Depending on the difference between room temperature and setpoint temperature the compressor and/or heat source will energize.
- If the room temperature and setpoint temperature are the same the compressor will operate in cooling and the electric heat will also energize.
- Should the room temperature fall below the setpoint temperature by two degrees, the compressor will stop and heating will

Unit-Mounted Controller Operation *(continued)*

continue to boost the room temperature back up to setpoint temperature.

- If the room temperature rises above the setpoint temperature by two degrees, heating will stop and cooling will continue to bring the room temperature back down to setpoint temperature.
- The fan will operate continuously at low speed while in Dry mode.
- In order to prevent short cycling, there is a two-minute minimum on time for both cooling and heating. The minimum off time is 3 minutes.
- Also, there is a 30-second delay between the start of the compressor and the start of the heat source.

Auto changeover operation

For Auto changeover mode (ACO), the unit must have a heat source and the control must first be configured properly, Heat source ON. See (Figure 28, Page 22).

Auto changeover mode will automatically operate either cooling or heating.

- The control will select heating or cooling operation depending on the setpoint temperature, room temperature and the differential setting selected in configuration (Figure 28, Page 22).

For Auto Changeover mode, first turn the unit on via the ON/OFF button.

- Select Auto mode via the Mode button.
- The room temperature and setpoint temperature will be displayed.
- Press either the Up or Down arrow buttons to change the setpoint temperature. The setpoint temperature will change by one degree with each successive press of the Up or Down arrow buttons. Holding the button in will change the temperature rapidly.

Place the setpoint temperature below the room temperature by the dead band amount selected in the configuration mode.

- The compressor will start and the unit will run cooling operation as described under Cool mode, page 26.
- If the set point temperature is above the room temperature by the dead band amount selected in configuration, the unit will run heating operation as described for heating modes on page 26.

Manual run mode

This is normal operating (non pre-program run) mode. Settings for temperature, mode and fan speed are selected by the user and will not change with the passing of time. The word PROGRAM does NOT display on the LCD.

Pre-programmed run mode

This feature allows the setpoint temperature to be changed according to the pre-programmed set point and time of day settings.

- The setpoint and time settings are programmed into the control through the 7-day programming setup (see Figure 29, Page 23).
- Pre-programmed run mode can be entered from Cool, Heat or Auto modes only.
- Pre-programmed run mode cannot be entered from Dry or Fan modes.
- Pressing the PROG button momentarily will enter or exit the pre-programmed run mode.
- PROGRAM will appear in the LCD display.
- The setpoint will change to the programmed setting at the time selected.

Wall Thermostat Operation

NOTICE

When power is first applied to the control or after a power outage there is a three minute delay before the compressor or electric heat will energize. This is to protect the unit from short cycling due to loss of power.

NOTICE

The controller must be configured with **Remote Thermostat ON** to operate using a wall thermostat. See (Figure 28, Page 22) for details. (Remote Thermostat OFF means the unit will be operated by the unit-mounted controller.)

In remote thermostat mode, **the unit-mounted keypad will have limited capability.**

- Some of the buttons will not be operable — only the FAN and TIME buttons will function.
- The ability to clear the FILTER CHECK warning will also be available by pressing the MODE and FAN buttons simultaneously.

THERMOSTAT selection

EMI thermostats

EMI offers several wall thermostats that are compatible with the EMI Series ductless split system air handlers.

- See the latest price list for a list of available thermostats.
- It is important to choose a thermostat that will match the equipment selected.
- For single-stage cooling or heating, choose a single-stage heat/cool thermostat.
- If an outdoor heat pump unit and an indoor unit with electric heat have been selected, then chose a two-stage heating, single-stage cooling thermostat.

Field-supplied thermostats

When selecting a thermostat other than one offered by EMI, it is important to choose a 24V thermostat that matches your application.

EMI equipment is compatible with most mercury bulb, digital or power-stealing thermostats.

Cooling only

Select a thermostat that is compatible with a cooling system.

The thermostat should have “R”, “Y” and “G” terminals and may also have a “C” terminal.

Cooling only with electric heat

Select a thermostat that is compatible with a cooling/electric heat system.

The thermostat should have “R”, “Y”, “W” and “G” terminals. The thermostat may also have a “C” terminal.

Heat Pump with electric heat

Select a thermostat that is compatible with a single-stage cooling, two-stage heat, heat pump system.

The thermostat should have “R”, “Y”, “O”, “W (or W2)” and “G” terminals. The thermostat may also have a “C” terminal.

If the indoor unit is not equipped with electric heat, then a single-stage heat pump thermostat is adequate.

Wall Thermostat Operation *(continued)*

FAN operation

The indoor unit utilizes a two-speed motor.

- The unit controller FAN button will allow the selection of the desired fan speed setting (High or Low).
- The wall thermostat will control the call-for-fan operation (on or off) through the low volt terminals, R and G.

After the room thermostat has been satisfied and the call for fan has been removed, the indoor fan will remain on for an additional 60 seconds. This increases efficiency by pulling the remaining energy from the unit.

Some thermostats are equipped with an AUTO/ON fan switch.

- When this switch is placed in the ON position, the indoor fan will run continuous.
- When the switch is in the AUTO position, the indoor fan will cycle with the call for heating or cooling.

COOLING operation

The wall thermostat will control the call for cooling operation (on or off) through the low volt terminals, R and Y.

After connecting the thermostat to the unit, place the system switch in Cool mode.

- Adjust the set-point temperature below the room temperature.
- The compressor and fan motors will start and cooling will begin.

Next, place the set-point temperature above the room temperature.

- The outdoor condenser will stop.
- The fan will operate as described in FAN operation.

NOTICE

Once cooling has cycled off or following a power outage, the compressor will not start for at least three minutes (short-cycle protection).

Wall Thermostat Operation *(continued)*

ELECTRIC HEAT operation

For wall thermostat operation with electric heat the control must be configured properly (Remote Thermostat ON, heat source ON). See (Figure 28, Page 22).

The wall thermostat will control the call for electric heat operation (On or Off) through the low volt terminals, R and W.

After connecting the thermostat to unit, place the system switch in Heat mode.

- Adjust the set-point temperature above the room temperature.
- The electric heat will energize along with the indoor fan motor.
- Heating will continue so long as the set-point remains above room temperature.

Next, place the set-point temperature below room temperature.

- The Electric heater will switch off and the indoor fan will remain on for an additional 60 seconds.

NOTICE

Once heating has cycled off or following a power outage, heating will not start for at least three minutes (short-cycle protection).

Optional HEAT PUMP WITH ELECTRIC HEAT *(Two-stage heating)*

For wall thermostat operation for two stage heating including a heat pump condenser and indoor electric heat, the control must first be configured properly (Remote Thermostat ON, heat source ON). See (Figure 28, Page 22).

The wall thermostat will control the call for electric heat operation (on or off) through the low volt terminals, R and W, and compressor (heat pump) heating through terminals R and Y.

After connecting the two stage heating thermostat to the unit, place the system switch in Heat mode.

- Adjust the set-point temperature above the room temperature. The compressor and fan motors will start and heating will begin.
- Depending on the thermostat selected, electric heat will also energize when the deviation between room temperature and set point temperature is high enough to call for second stage heating. (See the thermostat owner's manual for this feature.)

Place the set-point temperature below the room temperature.

- The outdoor condenser and electric heat will stop while the indoor fan will remain on for an additional 60 seconds.

NOTICE

Once heating has cycled off or following a power outage, heating will not start for at least three minutes (short-cycle protection).

Controller Features

Short Cycle Protection (ASCT)

The electronic control incorporates an anti-short-cycle timer (ASCT) feature designed to protect the compressor from short cycling. The ASCT is activated immediately following the off cycle of the outdoor unit. Once the room temperature is satisfied and the outdoor unit switches off, the ASCT will not allow the outdoor unit to restart until a three-minute time period has elapsed.

This feature will prevent the compressor and heat source from rapid restarts. Once switched off, or following a power outage, the compressor or heat source shall not restart for a minimum of three minutes.

Staggered Start protection

Designed for systems with electric heat, in heat pump and dry modes the staggered-start feature will prevent the compressor and electric heater from starting simultaneously. There is a thirty-second delay between the start of the compressor and start of the electric heater while in Dry mode and Heat pump mode.

Minimum run time

Once started, the minimum on time prevents either the compressor or heat source from cycling off prematurely. The minimum ON time for both the compressor and electric heat is two minutes. Minimum on time is available only while the control is configured for Unit mounted keypad operation. Minimum on times are disabled while in Remote thermostat mode.

LCD Back Light

The LCD display can be illuminated using the LCD back light feature. The selectable settings are Off, On, and Intermittent, and can be set in the Configuration.

- By selecting OFF, the backlight will remain off at all times.
- By selecting ON, the backlight will remain on at all times, including while in the Off mode interface.

- If Intermittent is selected, the backlight will remain for 10 seconds after the push of any button while the control is in the On mode or after the push of the ON/OFF button while in the Off mode interface.

Drain Pan Sensor

The drain pan sensors monitor the condensate level in each of the units drain pans. Should the water in either pan reach a critical level, the monitor will automatically signal the main control unit. The controls microprocessor will, in turn, switch off the condensing unit for a minimum of three minutes and until the fault condition has been cleared, to prevent further condensate production. A fault code, E02, will then flash on the controller's LCD display and will automatically reset once the fault condition is cleared.

Annunciation

The unit is equipped with an annunciation feature — the controller will beep, providing the user with audio feedback confirming that the microprocessor has received its commands. The annunciation feature must be activated in the configuration. The selections are OFF and ON. If OFF is selected, annunciation will remain off. If ON is selected, then annunciation will beep with the push of any button in the On mode or with the push of the ON/OFF button while in the off mode.

While in Remote thermostat mode, only the FAN and TIME buttons are activated and will beep when pressed.

Memory Backup

In the event of a power failure the control will retain all of its settings, including the mode of operation. When power is restored, the control will return to the mode of operation that it was in prior to the power failure, after a three minute time delay.

Controller Fault Conditions

Table 4 Unit-mounted controller fault indications

Code	Fault condition	Description
E01	Room air sensor fault	<p>If the room air sensor is disconnected, damaged or malfunctions the LCD display will flash error code E01 to signify that a fault has occurred.</p> <p>Operation will continue with the control using the last known value for the room air sensor.</p>
E02	Condensate fault	<p>If the control senses a condensate fault condition, either through the optional condensate pumps safety switch or the drain pan sensors, the LCD display will flash error code E02.</p> <p>The compressor will switch off for a minimum of three minutes and until the fault condition is corrected.</p>
E03	ID coil sensor fault	<p>The indoor coil sensor monitors the temperature of the indoor coil.</p> <p>If a freeze condition exists continuously for three minutes, the LCD will display error code E03 to signify that a fault has occurred.</p> <p>The compressor will switch off for a minimum of three minutes and until the fault condition is corrected.</p> <p>If the microprocessor detects a coil freeze condition four times within a 24 hour period, the FILTER CHECK indicator will appear.</p>

Maintenance



WARNING

Service should be performed by a **qualified service agency** and an annual system check is recommended.

Electrical shock hazard — Before removing the access panels, make sure that all power is disconnected from the unit. Failure to do so could result in injury or electric shock.

Clean the filter

EMI units are designed and constructed for reliability and long life with minimal maintenance. To insure peak operating efficiency, clean the filter as needed, following the procedure given here.



WARNING

The filter must be cleaned regularly — Allowing dust to collect on the filter will result in reduction of air flow and cause the unit to lose efficiency. This condition will cause the unit to malfunction.

Clean the filter monthly or when it is visibly dirty.

1. Lift and remove the front grille (Figure 30, Page 34).
2. Open the two clips at the base of the filter. carefully pull the filter out. Place the filter on a flat surface (Figure 31, Page 34).
 - a. To vacuum — Use a brush attachment and vacuum all visible dirt (Figure 32, Page 34).
 - b. To use a garden hose — Hose off thoroughly. Then let filter dry before replacing.

Figure 30 Remove the front access grille

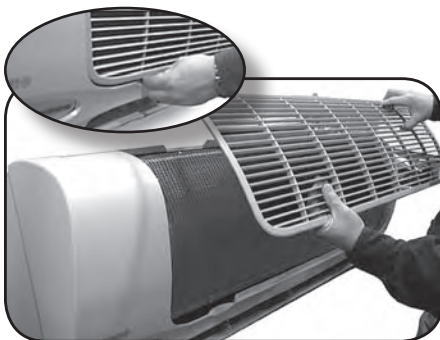

Figure 31 Removing the filter

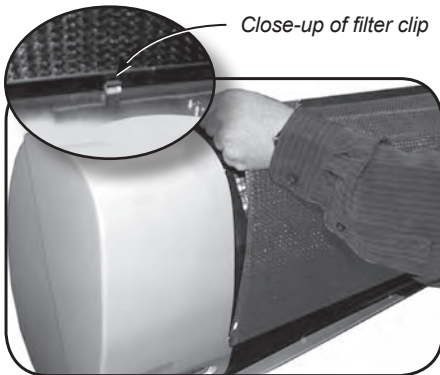

Figure 32 Cleaning with a vacuum



Maintenance *(continued)*

3. Replace filters, clips and front grille before operating the unit (Figure 33, Page 35).

**WARNING**

DO NOT operate the unit without the filter and front grille in place.

4. Vacuum dust from the return air grille and coil surface when cleaning the filter (Figure 34, Page 35).
5. Wipe the chassis with a damp cloth when needed (Figure 35, Page 35).

Figure 33 Replace filters and grille before operating the unit**Figure 34** Clean front grille and coil with a vacuum**Figure 35** Wipe the chassis with a damp cloth to clean

Troubleshooting

WARNING

Service should be performed by a **qualified service agency** and an annual system check is recommended.

Electrical shock hazard — Before removing access panels or control covers to expose moving parts of non-insulated live electrical components for service, disconnect all high volt power supplies to both the indoor unit and outdoor unit. Failure to do so could result in physical injury and/or electrical shock.

Wiring diagram

When trouble-shooting the indoor unit, please refer to the wiring diagram that is supplied with the equipment.

- The wiring diagram is located on the inside surface of the left end cap.
- Access the wiring diagram and wiring following the procedure on page 9.
- If you are unable to locate the wiring diagram, please call the factory technical service line at (800) 228-9364, and one can be faxed, mailed or e-mailed. Please have the full model and serial number available prior to calling.

Wiring requirements

EMI Series air handlers are designed to operate with EMI Series condensers.

- The air handler (indoor unit) and condenser (outdoor unit) must be independently connected to the electrical service panel and protected by separate time delay fuse or HACR breakers. (See the unit name plate for the correct breaker type and size).
- The indoor and outdoor units are also connected to each other via a 24V interconnect wiring.
- A transformer provides the low volt power source for the controls. The number of low volt interconnect conductors will be two to six depending on heating options and or thermostat selection.

Figure 36 Wiring connections — straight cool applications

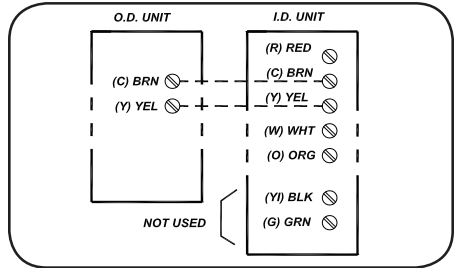

Figure 37 Wiring connections — heat pump applications

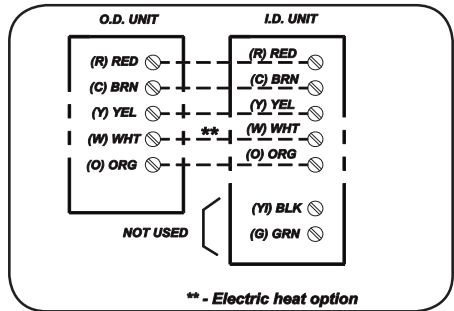
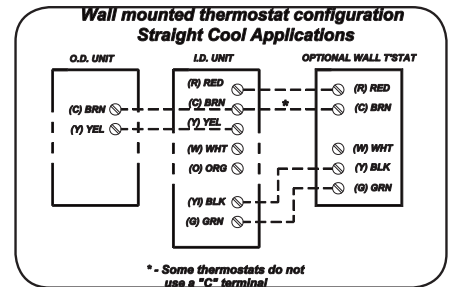

Figure 38 Wiring connections — straight cool applications with wall thermostat



Troubleshooting (continued)

- Interconnect wire should be at least 18 AWG.
- Refer to the unit wiring diagram for the interconnect diagram that matches your system.

Power supply check

When troubleshooting any EMI product, it is important to first check the rating plate for proper field voltage and breaker size.

Then use a voltmeter to check the incoming power supply to verify that it agrees with the rating plate.

- The incoming power must not exceed the nameplate voltage.
- The incoming power must not be below the minimum voltage stated on the rating plate (197V for units rated 208/230V and 104V for units rated 115V).

Also verify low voltage power — place a voltmeter across low volt terminals R and C at the indoor unit. The voltage should be 24V.

Test mode

Test mode is available for unit-mounted control configuration only. Use of test mode can aid in the functional check of the unit. It can also be a helpful tool when troubleshooting to solve a problem. While in test mode all timers are shortened. See (Figure 29, Page 23) for access information.



WARNING

While in test mode, all cycle times are reduced by 1/4 of original time for testing. Avoid short cycling the compressor. After system checks are complete, the control must be returned to normal operation.

DO NOT LEAVE THE SYSTEM IN TEST MODE.

Figure 39 Wiring connections — cooling/ electric heat applications with wall thermostat

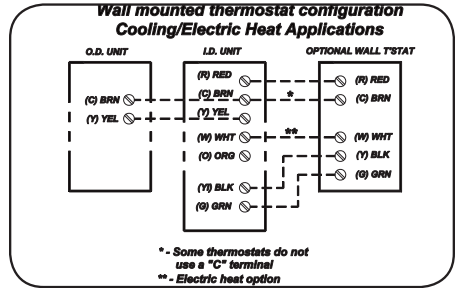
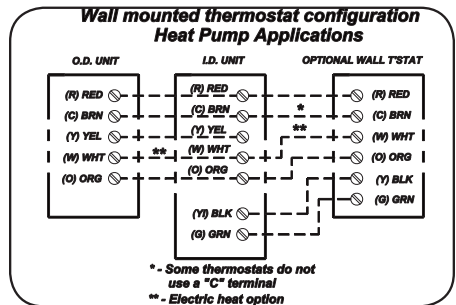

Figure 40 Wiring connections — heat pump applications with wall thermostat



Troubleshooting *(continued)*

Low voltage controls — cooling-only units

Cooling-only units utilize low volt interconnecting wires between the indoor unit, outdoor units and thermostat.

- For air handlers with unit-mounted controls, wires designated Y (yellow) and C (brown) of the indoor air handler should be connected to the corresponding Y (yellow) and C (brown) wires or terminals of the outdoor condenser.
- Other wires or terminals, such as R (red) or O (orange), may not be needed and should be protected by a wire nut to prevent contact with the junction box or other metal surfaces.

Interconnect wiring

- Unit-mounted controls — see (Figure 36, Page 36).
- Wall thermostat applications — see (Figure 37, Page 36).

Checking voltage

A 24V transformer located in the indoor air handler unit provides low volt control power to both the indoor air handler and outdoor condenser.

- The 24v power supply can be measured by placing a meter across the R and C low volt terminals of the air handler.
- The air handler will switch the condenser on and off through the yellow (Y) wire.
- When the air handler is calling for cooling, 24V can be measured between terminals Y and C.

Electric heat applications

Units with electric heat utilize a control relay located on the circuit board in the control box.

As a safety feature, an auto-reset limit switch located on the heater end plate or on the

heater assembly will interrupt power to the heater should an overheat condition occur.

Each electric heat assembly is also equipped with a one-time fuse link. Should electric heat temperatures rise above the auto resetting limit switch, a non-resetting, the one-time fuse link will open and the heater will remain off. To restart, a new fuse link is required.

The following current values apply when the unit is connected to a 230V power supply. These values include fan motor current. (If the supply power is different, the amperage will change.)

5 kw = 22.3 amps

3 kw = 13.5 amps.

Low voltage controls — optional heat pump with electric heat applications

Heat pump units with electric heat utilize four to six interconnecting, low volt wires depending on control setup and/or thermostat selected. Refer to the low volt interconnect section and figures 1 & 2 for your particular unit.

A 24V transformer located in the indoor air handler provides low volt control power to both the air handler and condenser.

- With high volt power supplied to the condenser, 24v can be measured across the red (R) and brown (C) wires at all times.

Cooling

The air handler will cycle the condenser on and off through the yellow (Y) wire. To check for a condenser signal, select cooling mode on the indoor unit or thermostat and place the setpoint temperature below room temperature. Then, with a voltmeter, check for 24 volts across the yellow (Y) and brown (C) wires. If no signal is found, then re-check all wiring connections to ensure that they match the low volt interconnect diagram. Check the

Troubleshooting *(continued)*

output of the 24v transformer (located in the air handler) to ensure that the control voltage is present.

EMI heat pump systems utilize a reversing valve is that is energized in the cooling mode.

- The reversing-valve signal is provided through the orange (O) low volt wire of the air handler or thermostat.
- It should remain energized constantly as long as the indoor unit or thermostat remains in cooling mode.
- To check for 24v reversing valve voltage, at the outdoor unit, place a voltmeter across the brown (C) and orange (O) wires while in the cooling mode.

Heating

Heat pump units can accommodate two-stage heating when an optional electric strip heater is present along with a heat pump condenser. The first stage is the compressor and the second is electric heat.

The air handler or wall thermostat will cycle the condenser through the yellow (Y) wire as it does in cooling, however the reversing valve will not be energized.

To check for a condenser signal, place the indoor unit or wall thermostat in heating.

- Next place the set-point temperature one degree above room temperature to call the first stage of heating.
- Then, with a voltmeter, check for 24 volts across the yellow (Y) and brown (C) wires at the condenser.
- The electric heat should be off at this point. Select a setpoint temperature that is more than two degrees above the room temperature to call for the second stage of heating.
- The electric heat should energize along with the 24v compressor signal between Y and C.
- Verify that the amp draw corresponds with to the electric heat rating.

The following current values apply when the unit is connected to a 230V power supply. These values include indoor fan motor current. If the supply power is different, this will affect the amp draw of the heater.

5kw = 22.3 amps

3kw = 13.5 amps

Units with electric heat utilize a control relay located on the circuit board in the control box.

As a safety feature, an auto-reset limit switch located on the heater assembly will interrupt power to the heater should an over-heat condition occur.

Each electric heat assembly is also equipped with a one-time fuse link. Should electric heat temperatures rise above the auto resetting limit switch, a non-resetting, the one-time fuse link will open and the heater will remain off. To restart, a new fuse link is required.

Units with condensate pumps

EMI Air Handlers are available with an optional condensate pump. Condensate pumps are recommended when it is not possible to gravity drain the condensate from the indoor unit.

The maximum lift for the pumps will vary. Consult the pump instructions for the maximum lift.

Condensate generated by the air handler will collect in the pump's reservoir.

- When the water level is high enough a the pump motor will energize clearing the water from the reservoir.
- Should the water exceed the maximum preset level, a safety switch will open, interrupting the (Y) signal to the condenser.
- This will prevent the air handler from generating more condensate.

Frequently Asked Questions

Q: The system has just been installed using an EMI indoor unit and a non-EMI condenser. There is no display and the unit will not operate.

A: EMI air handlers are manufactured with a low volt transformer installed. When connecting an EMI air handler to a non-EMI condenser, check to ensure that there is no 24v control transformer in the outdoor unit. Only one transformer is required. If both the indoor unit and outdoor unit contain a transformer, one must be removed from the system.

Q: The condenser will not start although the indoor unit appears normal. What should I do?

A: At the indoor unit, make sure that the control is in cooling and the setpoint temperature is below room temperature. Next, using a volt meter, check for 24v across the yellow (Y) and brown (C) wires. If 24v is present then check for wiring breaks or improper connections between the indoor and outdoor units.

A: EMI condensers are equipped with a manual reset high-pressure switch. It is located on the rear panel above the service valves. To reset, simply push the red button in. If the switch was tripped there will be a “click” when it resets.

A: If the unit is equipped with a condensate pump check to see if the safety float has been tripped. This can be done by first disconnecting both ends of the float switch. Then with an Ohmmeter, check for continuity across the switch. If the switch is open then the pump is not clearing or the switch may be bad.

Q: The display on the indoor unit is blank. What should I do?

A: Check the power supply (see “Power supply check” Section). If the unit still fails to turn on via the On/off button then inspect the control box for any apparent wires that may have come loose during shipping. Also inspect the circuit boards for burnt components. If no obvious problem can be found then replace all circuit boards including the unit keypad. Do not attempt to trouble shoot the individual circuit boards. Contact tech service 1-800-228-9364

Q: The display tends to flicker at times. Is this normal?

A: A small amount of flickering of the display is normal. Depending on the room lighting, flickering may be noticeable at some times more than others.

Q: How long will the fan run?

A: While the unit is in cooling or heating and auto fan mode is selected, Fan speed will be determined by the microprocessor and speed adjustment will be made according to room and setpoint temperatures. The fan will switch to High speed when room temperature deviates by more than two degrees from setpoint. The fan will switch to Low speed if the deviation is one degree. When the room temperature reaches setpoint temperature the heat/cool call is dropped. The fan will then stay on for an additional 60 seconds to purge unit of any residual energy. If High or Low is selected then the fan will operate continuous regardless of set point or room temperatures.

Frequently Asked Questions *(continued)*

Q: What causes my indoor unit to freeze-up?

A: Air handler freeze up is usually the symptom of another problem. Units are equipped with freeze protection to prevent freeze up from occurring. If freeze up does occur then check the following.

- Check that the freeze sensor located in the lowest part of the coil. Generally this is where freeze up will begin.
- Check that the freeze sensor inserted fully and snug in the coil fin. If not another location may need to be selected. Be careful not to insert the sensor directly into the coil tube rather insert the sensor between two tubes.
- Check the indoor air filter. It should be clean and free of dirt. A dirty filter will reduce airflow and efficiency. Also check that the coil is clean. If the coil is dirty then it should be cleaned using an appropriate coil cleaner or mild detergent.
- Is the equipment being operated in cooling mode when outdoor temperatures are below 32°F? If it is, then the condenser should be fitted with low ambient control so that the proper system pressures are maintained.
- Does the system have the proper refrigerant charge? A system low on refrigerant can cause coil freeze-up. To check system charge you will need to contact a qualified refrigeration service technician. Refrigerant charge information can be found in IOM for the outdoor condensing unit.

Q: I lost my infrared remote. How do I operate the unit?

A: All infrared remote functions can be accessed via the unit-mounted control keypad.

Specifications and Dimensions

Figure 41 Dimensions and shipping weights

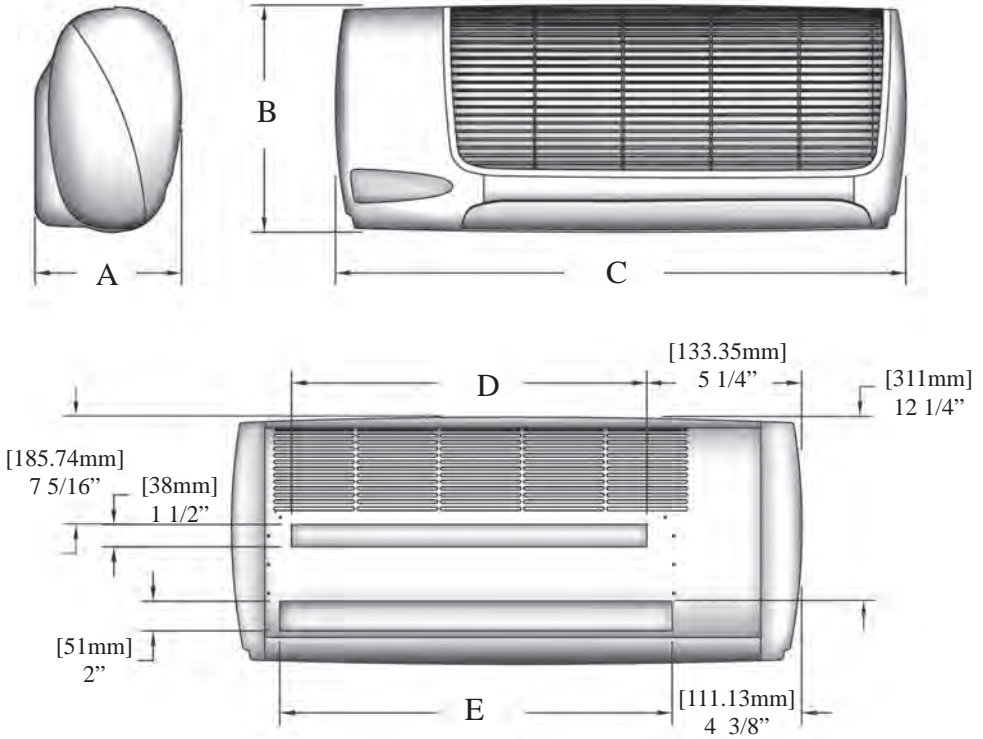

Model	A	B	C	D	E	Shipping weight
	Depth in (mm)	Height in (mm)	Length in (mm)	Mounting bracket clearance in (mm)	Tubing access clearance in (mm)	Pounds (kg)
WLHG09	9 7/8" (251)	15 1/4" (387)	38 1/2" (978)	24" (610)	26 1/2" (673)	58.0 (26.4)
WLHG12	9 7/8" (251)	15 1/4" (387)	38 1/2" (978)	24" (610)	26 1/2" (673)	60.3 (27.4)
WLHG24	9 7/8" (251)	15 1/4" (387)	48 1/2" (1232)	34" (864)	36 1/2" (927)	66.2 (30.0)
WLCG30	9 7/8" (251)	15 1/4" (387)	58 1/2" (1486)	44" (1118)	46 1/2" (1181)	90.1 (40.9)
WLCG36	9 7/8" (251)	15 1/4" (387)	58 1/2" (1486)	44" (1118)	46 1/2" (1181)	90.1 (40.9)

Specifications and Dimensions *(continued)*

Table 5 WLCG/WLHG electrical specifications

MODEL	VOLTS/HZ/PH	FAN RLA	HP	HEATER K.W.	AMPS	TOTAL AMPS	MIN VOLT	M.C.A.	HACR BRKR
09-12	115/60/1	0.64	0.02	–	–	0.64	104	0.8	15
	208/230/60/1	0.34	0.02	–	–	0.34	197	0.4	15
	208/230/60/1	0.34	0.02	3	13.04	13.38	197	16.7	20
24	115/60/1	1.2	0.083	–	–	1.2	104	1.5	15
	208/230/60/1	0.56	0.07	–	–	0.56	197	0.7	15
	208/230/60/1	0.56	0.07	3	13.04	13.6	197	17	20
	208/230/60/1	0.56	0.07	5	21.74	22.3	197	27.9	30
30/36	208/230/60/1	0.8	0.10	–	–	0.8	197	1	15
	208/230/60/1	0.8	0.10	5	21.74	22.54	197	28.2	30

Table 6 WLCG/WLHG interconnecting line sizes

Capacity	Max. Equivalent Length	Max. Lift	Max. Trap Height	Liquid Line	Suction Line	Condensate Line
		"H"	"P"	O.D.	O.D.	I.D.
9,000	50' (15 m)	20' (6 m)	15' (5 m)	1/4"	1/2"	1/2"
12,000				1/4"	1/2"	1/2"
18,000*	100' (30 m)	35' (11 m)	20' (6 m)	3/8"	5/8" *	1/2"
24,000				3/8"	3/4"	1/2"
30,000				3/8"	3/4"	1/2"
36,000				3/8"	3/4"	1/2"

* Must bush down to 5/8" interconnect for 18K system

Table 7 Discharge air speed and flow at 230V

Model	High speed CFM (l/s)	Low speed CFM (l/s)	Coil	FPM (m/s)	Throw feet (m)	Observed sound values (dBA)
WLHG 09-12	400 (190)	350 (170)	Dry	900 (4.6)	15 (4.6)	45
WLHG24	750 (350)	675 (320)	Dry	1,225 (6.2)	25 (7.5)	56
WLCG30	1,100 (520)	900 (420)	Dry	1,250 (6.4)	27 (8.2)	60
WLCG36	1,100 (520)	900 (420)	Dry	1,250 (6.4)	27 (8.2)	60



NOTICE

Due to ongoing product development, designs, specifications, and performance are subject to change without notice. Please consult the factory for further information.

WLCG/WLHG System Options

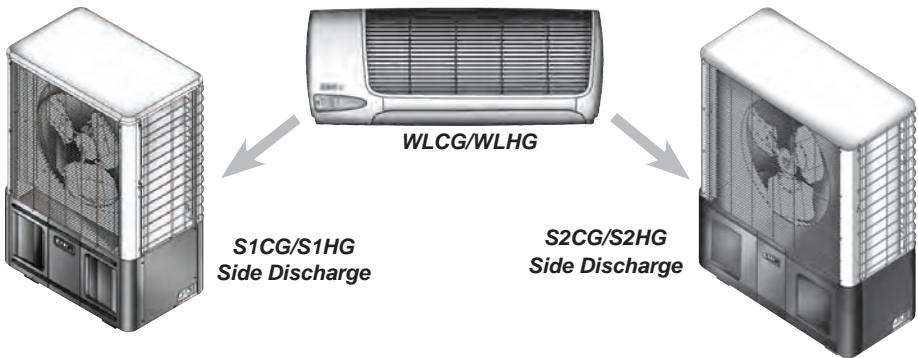
Table 8 Cooling system with wall units

Condenser	Wall Units	Btuh	SEER	SHR	EER	Ref.
S1CG9	WLHG09	9,000	13.0	0.74	12.2	R410A
S1CG2	WLHG12	12,000	13.0	0.68	11.9	R410A
S1CG8	WLHG24	18,000	13.0	0.77	12.0	R410A
S1CG4	WLHG24	23,800	13.0	0.67	11.4	R410A
S1CG3	WLCG30	28,200	13.0	0.79	11.7	R410A
S1CG6	WLCG36	33,600	13.0	0.69	11.6	R410A
S2CG99	(2) WLHG09	18,000	13.0	0.73	12.1	R410A
S2CG22	(2) WLHG12	24,000	13.0	0.68	12.0	R410A
S2CG92	(1) WLHG09+ (1)WLHG12	21,000	13.0	0.70	12.0	R410A

Table 9 Heat pump system with wall units

Condenser	Wall Units	Cooling Btuh	Cooling Btuh	SEER	HSPF	SHR	EER	COP	Ref.
S1HG9	WLHG09	9,000	9,000	13.0	7.7	0.72	12.8	3.3	R410A
S1HG2	WLHG12	12,000	12,000	13.0	7.7	0.69	11.8	3.3	R410A
S1HG8	WLHG24	18,000	18,000	13.0	7.7	0.76	11.9	3.5	R410A
S1HG4	WLHG24	23,800	23,800	13.0	7.7	0.71	11.9	3.5	R410A
S2HG99	(2) WLHG09	18,000	18,000	13.0	7.7	0.73	12.1	3.3	R410A
S2HG22	(2)WLHG12	24,000	24,000	13.0	7.7	0.68	12.0	3.3	R410A
S2HG92	(1) WLHG09+ (1) WLHG12	21,000	21,000	13.0	7.7	0.70	12.0	3.3	R410A



WLCG/WLHG



**T2CG/T2HG, T3CG/
T3HG and
T4CG/T4HG 2, 3 and 4
Zone
Top Discharge**

Table 10 Heat pump system with wall units

Condenser	Wall unit	Cooling Btuh	Heating Btuh	SEER	HSPF	SHR	EER	COP	Ref.
T2HG2400	WLHG12, WLHG24	35,800	32,400	13.0	7.7	0.69	11.5	3.2	410A
T2HG4400	(2) WLHG24	47,500	44,000	13.0	7.7	0.67	11.5	3.1	410A
T2HG9800	WLHG09, WLHG24	27,000	25,000	13.0	7.7	0.76	11.5	3.4	410A
T2HG8800	(2)WLHG244	36,000	33,000	13.0	7.7	0.74	11.5	3.4	410A
T3HG2220	(3)WLHG12	36,000	31,200	13.0	7.7	0.72	11.5	3.1	410A
T3HG2240	(2) WLHG12, WLHG24	47,500	42,500	13.0	7.7	0.71	11.5	3.1	410A
T3HG9920	(2) WLHG09, WLHG12	30,000	27,400	13.0	7.7	0.76	11.5	3.3	410A
T3HG9980	(2) WLHG09, WLHG24	36,000	33,500	13.0	7.7	0.76	11.5	3.4	410A
T3HG9990	(3)WLHG09	27,000	25,500	13.0	7.7	0.78	11.5	3.5	410A
T4HG2222	(4)WLHG12	48,000	41,500	13.0	7.7	0.72	11.5	3.1	410A
T4HG9922	(2)WLHG09, (2)WLHG12	42,000	37,800	13.0	7.7	0.74	11.5	3.2	410A
T4HG9992	(3)WLHG09, WLHG12	39,000	35,900	13.0	7.7	0.76	11.5	3.4	410A
T4HG9999	(4)WLHG09	36,000	34,000	13.0	7.7	0.78	11.5	3.5	410A

Table 11 Cooling system with wall units

Condenser	Wall units	Btuh	SEER	SHR	EER	Ref.
T2CG2400	WLHG12, WLHG24	35,800	13.0	0.69	11.5	410A
T2CG4400	(2) WLHG24	47,500	13.0	0.67	11.5	410A
T2CG9800	WLHG09, WLHG24	27,000	13.0	0.76	11.5	410A
T2CG8800	(2)WLHG24	36,000	13.0	0.74	11.5	410A
T3CG2220	(3)WLHG12	36,000	13.0	0.72	11.5	410A
T3CG2240	(2) WLHG12, WLHG24	47,500	13.0	0.71	11.5	410A
T3CG9920	(2) WLHG09, WLHG12	30,000	13.0	0.76	11.5	410A
T3CG9980	(2) WLHG09, WLHG24	36,000	13.0	0.76	11.5	410A
T3CG9990	(3)WLHG09	27,000	13.0	0.78	11.5	410A
T4CG2222	(4)WLHG12	48,000	13.0	0.72	11.5	410A
T4CG9922	(2)WLHG09, (2)WLHG12	42,000	13.0	0.74	11.5	410A
T4CG9992	(3)WLHG09, WLHG12/	39,000	13.0	0.76	11.5	410A
T4CG9999	(4)WLHG09	36,000	13.0	0.78	11.5	410A

Test Unit Performance Data Sheet

NOTICE

The Test Unit Performance Data sheet is provided for use by a qualified service professional in the event that there is a problem with the unit. In order for our Technical Service Department to better serve you, please complete.

Have this information ready when calling. Make sure to include the Model Number, Serial Number, and Date of installation.

Call our Technical Support Department
@ 1-800-228-9364.

Model Number		Date:
Serial Number		Technician:
		Mode: Cooling
Indoor Section		Notes
Air handler Entering Air – DB		
Air handler Entering Air – WB		
Air handler Leaving Air – DB		
Air handler Leaving Air – WB		
Outdoor Section		
Entering Air		
Leaving Air		
Temperature Split		
Operating Pressures		
Compressor Suction – PSIG		
Compressor Discharge – PSIG		
Power Input		
Compressor – Volts		
Compressor – Amps		
OD Fan Motor – Volts		
OD Fan Motor – Amps		
ID Fan Motor – Volts		
ID Fan Motor – Amps		
Total Volts		
Total Amps		
Temperatures – Degrees F		
Compressor Suction		
Compressor Discharge		
Liquid Out Cond.		
Liquid before Expansion		
Suction out Air handler		
Capacity Calculations		
DB – Temp Split at Air handler		
Test Summary		
Compressor Superheat		
Sub Cooling		

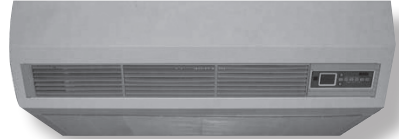
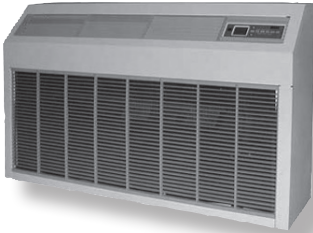
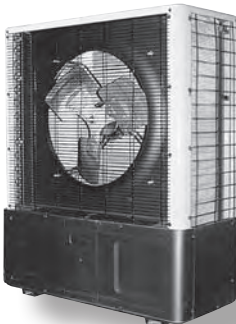
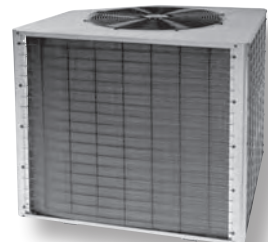
EMI's Product Line**Indoor Units****WLCG/WLHG**
High Wall Air Handler**CACG/CAHG**
Cassette Air Handler**UNCG/UNHG**
Universal Floor or Ceiling Air Handler**Outdoor Units****S2CG/S2HG Dual Zone**
Side Discharge**S1CG/S1HG**
Single Zone
*Side Discharge***T2CG/T2HG, T3CG/
T3HG and
T4CG/T4HG 2, 3 and 4**
Zone
Top Discharge



Phone: 1-800-228-9364
Fax: 1-800-232-9364

EMC Ductless
Comfort Where It Counts

2201 Dwyer Ave.
Utica, NY 13501