

INSTALLATION, OPERATION, AND MAINTENANCE MANUAL



This manual is intended as an aid to qualified service personnel for proper installation, operation, and maintenance of the WatterSaver™ Heat Pump Water Heater.

Read this manual carefully before attempting to install or operate the WatterSaver™ Heat Pump Water Heater. Failure to follow these instructions or use this water heater for its intended purpose may result in fire, electrical shock, scald injury, explosion, property damage, personal injury, or death.

INSTALLER

- (1) Affix these instructions on or adjacent to the water heater.
- (2) Before leaving the premises, review this manual to be sure the heater has been installed correctly. Start and operate the unit for one complete cycle and make sure the water temperature is acceptable to the consumer.

OWNER

Retain this manual and the attached warranty for future reference. Retain the original receipt as proof of purchase.

For technical service or warranty information on your WatterSaver™ Heat Pump Water Heater, see the attached warranty and please have the following information ready when calling:

- Model Number _____
- Serial Number _____
- Date of Installation _____

For questions regarding the information provided in this installation manual, call toll free:

1-877-317-2188

SAFETY INSTRUCTIONS

- Do not use the WatterSaver™ Heat Pump Water Heater if it has been dropped or damaged in any way.
- The WatterSaver™ must not be installed in any area where flammable liquids or vapors may be present. Do not store or use gasoline or other combustible materials or liquids near or adjacent to this water heater.
- Do not use the WatterSaver™ in conjunction with a spa or hot tub.
- Check the rating plate on the WatterSaver™ before installation to make certain the voltage shown is the same as the electric supply to the water heater.
- The WatterSaver™ must be connected only to a properly grounded electrical supply. Do not fail to properly ground this water heater.
- The WatterSaver™ should only be serviced by qualified service personnel.
- Turn off the electrical supply before servicing the WatterSaver™.

IMPORTANT NOTE

The WatterSaver™ Heat Pump Water Heater should never be stored or installed on its side. Upright transportation is recommended. If it becomes necessary to transport the water heater on its side, the manufacturer recommends that the unit be in the upright position for a minimum of two hours prior to operation. Failure to follow these instructions may result in damage to the WatterSaver™ and will void the warranty.

SPECIFICATIONS

VOLTAGE: 208/240V AC
FREQUENCY: 60 HZ
PHASE: Single
BREAKER: 30 AMPS
MCA: 22.5A
EF RATING: 2.4
FIRST HOUR RATING:
61.8 Gallons
NOMINAL OUTPUT:
5100 Btuh
NOISE LEVEL: 60 dB
HEIGHT: 60"
DIAMETER: 22.25"
WEIGHT: 180 Lbs.
CAPACITY: 50 Gallons
WORKING PRESSURE:
150 PSIG
REFRIGERANT: R-134A
CHARGE: 16 oz.

TABLE OF CONTENTS

Safety Instructions	1
Consumer Information	2
Site Location	3
Installation Instructions	4
Piping Installation	6
Electrical Connections	7
Installation Checklist	8
Start-Up And Operation	9
Water Temperature Regulation	9
Operational Conditions	10
Water Heater Maintenance	11
Troubleshooting Guide	11
Heating Element Replacement	13
Common Replacement Parts	14



Water temperature over 125° F can cause severe burns or death from scalding. Feel the water before bathing or showering.

Children, disabled, and elderly are at highest risk of being scalded.

See the instruction manual before setting the water temperature on the WatterSaver™ Heat Pump Water Heater. Temperature limiting valves are available for use and may be purchased at most plumbing supply stores.

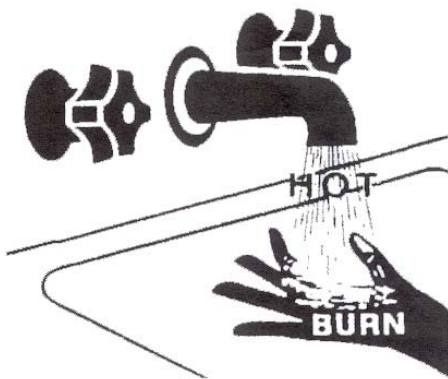

CONSUMER INFORMATION

This water heater should be installed in accordance with the local code authority having jurisdiction; the power company or electric utility; and this installation manual. In the absence of local code requirements, follow the regulations set forth in the latest edition of The National Electrical Code, NFPA 70. This is available from the following:

National Fire Protection Association
1 Batterymarch Park
Quincy, MA 02269

American National Standards Institute
1430 Broadway
New York, NY 10018

Check your phone listings for the Local Authorities having jurisdiction over your installation.

CONSUMER RESPONSIBILITIES

This manual has been prepared to acquaint you with the installation, operation and maintenance of your WatterSaver™ Heat Pump Water Heater and to provide important safety information in these areas.

We urge you to read all of the instructions thoroughly before attempting the installation or operation of this water heater. This manual should be kept for future reference.

The manufacturer of this water heater will not be liable for any damages caused by failure to comply with the installation and operating instructions outlined in this manual.

If you lack the necessary skills required to properly install this water heater or you have difficulty following the directions, you should not proceed, but have a qualified person perform the installation of this water heater.

A rating plate identifying your water heater can be found on the front of the jacket. When referring to your water heater, always have the information listed on the rating plate readily available.

Retain your original receipt as proof of purchase.

TAMPERING AND MODIFICATION



Tampering with the thermostat, heater elements, electrical connections, or temperature and pressure relief valve is dangerous and may result in serious injury or death. Tampering voids all warranties. Only properly trained, qualified service personnel should service these components. Do not attempt to modify or change this water heater in any way.

INSULATION BLANKET

Some governing bodies may require the use of external insulation blankets when water heaters are installed in newly constructed homes and additions. If an insulation blanket is applied to the WatterSaver™ Heat Pump Water Heater, **CAUTION** must be exercised so as to not restrict its proper function and operation. Please note the following:

- Do not cover the temperature and pressure relief valve or any labels or instruction materials applied to the water heater. These labels must remain visible for reference by the user. Do not remove these labels as they are a permanent part of the water heater as required by the certification agencies and/or the Federal Government.
- Do not cover any access panels leading to element compartments. Do not cover any doors on the water heater.
- Do not cover any opening on the shroud that will obstruct air flow inlet or outlet to the water heater.

EARTHQUAKE NOTICE



This water heater must be braced, anchored, or strapped to avoid falling or moving during an earthquake. Contact local utilities for code requirements in your area or call the toll free number on the front of this manual for instructions.

SITE LOCATION

Select a location near the center of the water piping system. It must be installed indoors and in a vertical position on a level surface.

The WatterSaver™ should be located in an area not subject to freezing temperatures. Water heaters located in unconditioned spaces (i.e. attics, basements, etc.) may require the water piping and drain piping to be insulated to protect against freezing. The drain and controls must be easily accessible for operation and service.

IMPORTANT: Local codes and requirements in your area may require the installation of your water heater be accomplished in a way that the bottom of the unit is elevated at least 6 inches from the floor.

The WatterSaver™ Heat Pump Water Heater should be located in an area where leakage of the tank or connections will not result in damage to the area adjacent to the water heater or to lower floors of the structure.

It is recommended that a suitable drain pan be installed under the water heater to protect the property from damage which may occur from normal condensate formation on the tank or leaks in the tank and pipe connections. The pan must limit the water level to a maximum depth of 2½ inches and be two inches wider than the heater and piped to an adequate drain. Locate the water heater near a suitable inside drain. Outside drains are subject to freezing temperatures which can obstruct the drain line. The piping should be at least ¾" ID and pitched for proper drainage. Refer to *Figure 2*.



DO NOT INSTALL OUTDOORS. This water heater is certified for indoor installation only. Failure to follow these instructions could result in fire, property damage, personal injury or death.



Areas where flammable liquids (gasoline, solvents, liquid propane, butane, etc.) or other substances which emit flammable vapors are stored are not suitable for water heater installation. Natural air movements can carry flammable vapors some distance from where they are stored or used. The water heater thermostat contacts can arc and ignite these vapors causing property damage, serious burns or death. Never store or use flammable substances in the same room or area containing an electric water heater. Gasoline or other flammable substances must never be used in the same room or area containing a water heater or other spark producing devices.

IMPORTANT: The water heater shall be located so it is not subject to physical damage by moving vehicles or area flooding. (Figure 1)

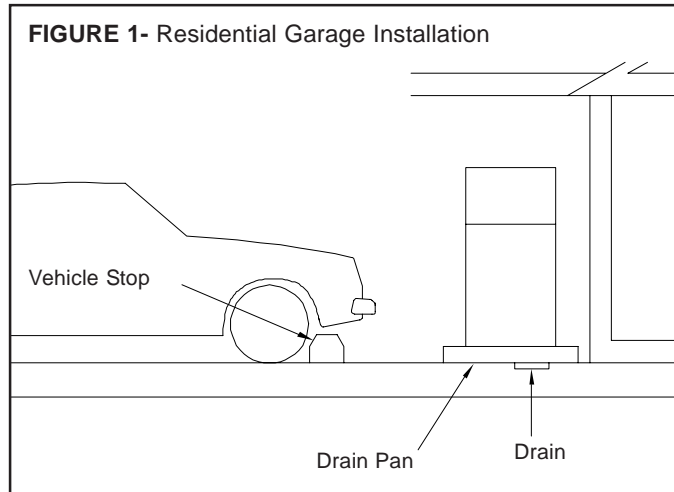

All condensate drain lines and T&P valve drains must be piped separately and routed to an adequate drain. To protect the WatterSaver's outer finish, do not pipe drain lines into the drain pan.

Failure to follow the instructions in this installation, operation, and maintenance manual will release the manufacturer from any liability for any water damage in connection with this water heater.

INSTALLATION INSTRUCTIONS

PRIOR TO INSTALLATION, BE SURE TO HAVE THE FOLLOWING TOOLS AND MATERIALS AVAILABLE:

- Propane Torch
- 95/5 Solder
- Soldering Flux
- Sand Cloth
- Pipe Cutter
- Pipe Thread Tape
- Phillips Screwdriver
- 1/4" Nut Driver
- Wire Nuts
- Wire Stripper/Cutter
- 3/8" I.D. Condensate Drain Tube
- 1/2" I.D. Condensate Drain Tube
- Pipe and Plumbing Fittings
- Tape Measure
- 10" Adjustable Wrench

1. Select the proper installation site for the WatterSaver™ and unpack it in the location where it will be installed.

IMPORTANT: The WatterSaver™ must not be installed outdoors, in a corrosive environment, or in an area where leakage of the tank or plumbing connections will damage adjacent areas or lower floors of the structure. For best results, make certain the unit is placed on a level surface.

2. Use a 1/4" nut driver to loosen the screws around the base of the shroud and remove it from the water heater. It is not necessary to remove the screws as the holes in the base of the shroud are slotted.

3. Remove the screws from the shroud and separate the halves.

4. Install plumbing to the tank. Ensure plumbing connections will allow the installation and removal of the shroud after all plumbing is complete (See "Water system Piping").

5. Install primary and secondary condensate drain lines to the evaporator pan and route to an adequate drain. (Figure 2)

6. Ensure the toggle switch on the control board (see "replacement parts list" on page 16 for location) is in the "HP" position. (In the "ELEC" position, the heat pump system is disabled and the unit will operate as an electric resistance water heater ONLY.)

7. Connect wires L1, L2, and Ground to the electric box located in front of the evaporator coil on top of the tank.

8. Replace the shroud and ensure wires L1, L2, and Ground pass through the opening in the top of the shroud.

WATER SYSTEM PIPING

Water piping, fittings, and valves must be properly installed for the correct and safe operation of the WatterSaver™ Heat Pump Water Heater. Please note the following:

- **DO NOT** Install the water heater with piping that is unsuitable for drinking water (iron piping, PVC piping, or piping that has been treated with chromates, boiler seal, or other chemicals). Use only new piping such as copper, CPVC, or polybutylene.
- **DO NOT** Add any chemicals to the piping which could contaminate the water supply.
- **DO NOT** Use any type of pump, valve, or fitting that is unsuitable for potable water.
- **DO NOT** Install check valves in the cold water supply to the unit.
- **DO NOT** Use valves that excessively restrict water flow. Use only full flow or gate valves.
- **DO NOT** Use any lead-based solder in potable water lines. Use 95/5 tin-antimony or another suitable non-lead solder.

• **DO NOT** Tamper with any components of the water heater. Tampering is dangerous and can result in property damage, severe injury, or death. Tampering with the unit voids all warranties so only a qualified technician should service the unit.



Never operate an empty or partially filled water heater. This can result in serious damage to the tank and will destroy the heating elements.

TEMPERATURE AND PRESSURE RELIEF VALVE (T&P VALVE)



Do not attempt to operate the WaterSaver™ without a properly installed temperature and pressure relief valve. Operating the WaterSaver™ without a T&P valve will void the warranty and can result in property damage, personal injury, or death.

For protection against excessive pressure and temperatures, a temperature and pressure relief valve must be installed in the opening marked "T&P Valve" and connected to a proper discharge line which terminates at an adequate drain. (figure 2) A T&P valve is furnished with the water heater.

This valve must be design certified by a nationally recognized testing laboratory as meeting the requirements for relief valves and automatic shut-off devices for hot water supply systems.

The function of the T&P valve is to discharge water in large quantities in the event of an excessive temperature or pressure build up in the water heater. The valve must not be in contact with any electrical part or exceed the working pressure of the water heater as stated on the rating plate.



Do not use an old or existing T&P valve with your WaterSaver™ Heat Pump Water Heater as it may be damaged or inadequate for the pressure of the unit.

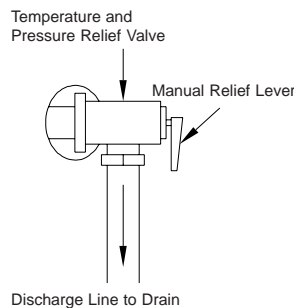
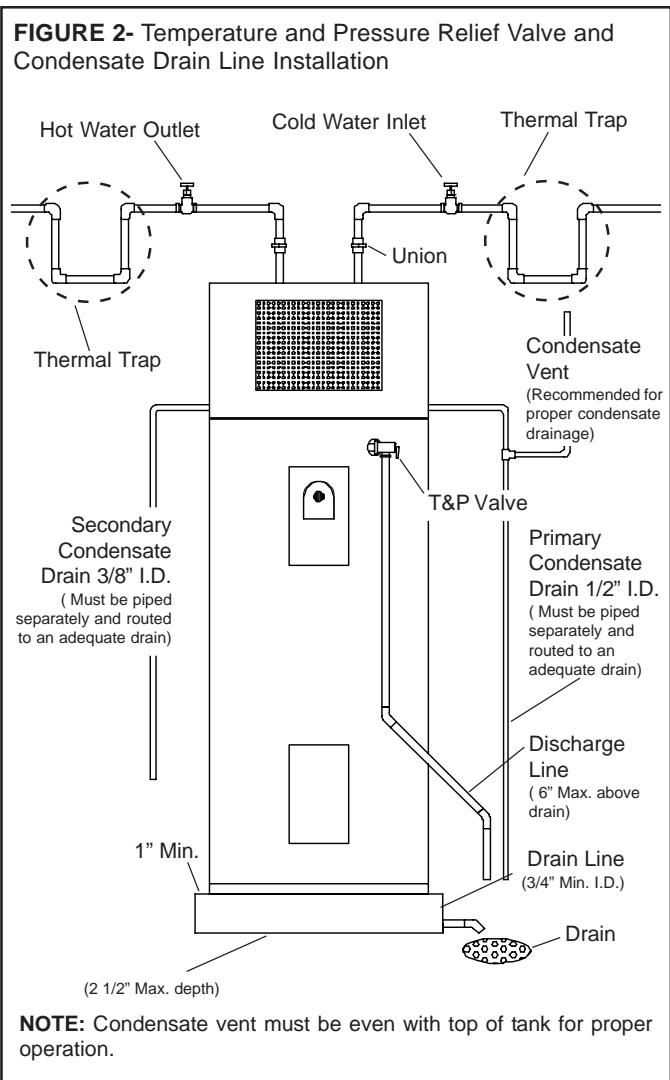

Manually operate the T&P valve at least once a year to make sure it works properly. Because discharged water can be hot, stand clear of the outlet and slowly lift the manual relief lever on the valve. Then allow the water to flow for 5-10 seconds and let the valve "snap" closed. If, after several attempts, the valve fails to close and continues to release water, immediately shut off electrical power and the cold water inlet valve and call a qualified technician.



Discharging water will be hot and can cause scald injuries or property damage. Discharge lines must be properly installed and piped to an adequate drain.

DISCHARGE/DRAIN LINES

- Must not be smaller than the pipe size of the relief valve or drain stubs.
- Must not be capped, blocked, plugged or contain any valve that obstructs flow to the drain.
- Must terminate a maximum of 6 inches above a floor drain or external to the building provided the external drainage is below the level of the WaterSaver™.
- Must be capable of withstanding 250° F without distortion.
- Must be installed to allow complete drainage of the T&P valve and discharge line.

CLOSED SYSTEM/THERMAL EXPANSION

Periodic discharge of the temperature and pressure relief valve may be due to thermal expansion in a closed water supply system. The water utility supply meter may contain a check valve, backflow

preventer, or water pressure reducing valve. This will create a closed water system. During the heating cycle of the water heater, water expands, causing pressure inside the tank to increase. Under these conditions, the T&P valve may discharge hot water, resulting in a loss of energy and a build-up of lime on the relief valve seat. To prevent this:

1. Install a diaphragm-type expansion tank that is suitable for potable (drinking) water on the cold water supply line. The expansion tank must have a minimum capacity of 1.5 U.S. gallons per 50 gallons of stored water.

2. Install a 125 PSI pressure relief valve in the cold water supply line. **Make sure the discharge of this valve is directed to an open drain and protected from freezing.**

IMPORTANT: Contact a local water supplier or plumbing inspector for information on how to control this situation. Do not plug the T&P valve.

PIPING INSTALLATION

Piping, fittings, and valves should be installed according to the installation drawing shown in **Figure 3**. If the indoor installation area is subject to freezing temperatures, the water piping must be protected by insulation.

Water supply pressure should not exceed 80% of the unit's working pressure (150 PSIG) as stated on the rating plate and on Page 1 of this manual. If this occurs, a pressure reducing valve with a by-pass may need to be installed in the cold water supply line. This should be placed on the supply to the entire house in order to maintain equal hot and cold water pressures.



Heat cannot be applied to the hot and cold water connections as they may contain non-metallic parts. If solder connections are used, solder the pipe to the threaded adapter before attaching the adapter to the hot and cold water connections.

FIGURE 3- Water Piping Installation

In a closed system use **either** a thermal expansion tank **or** pressure relief valve.

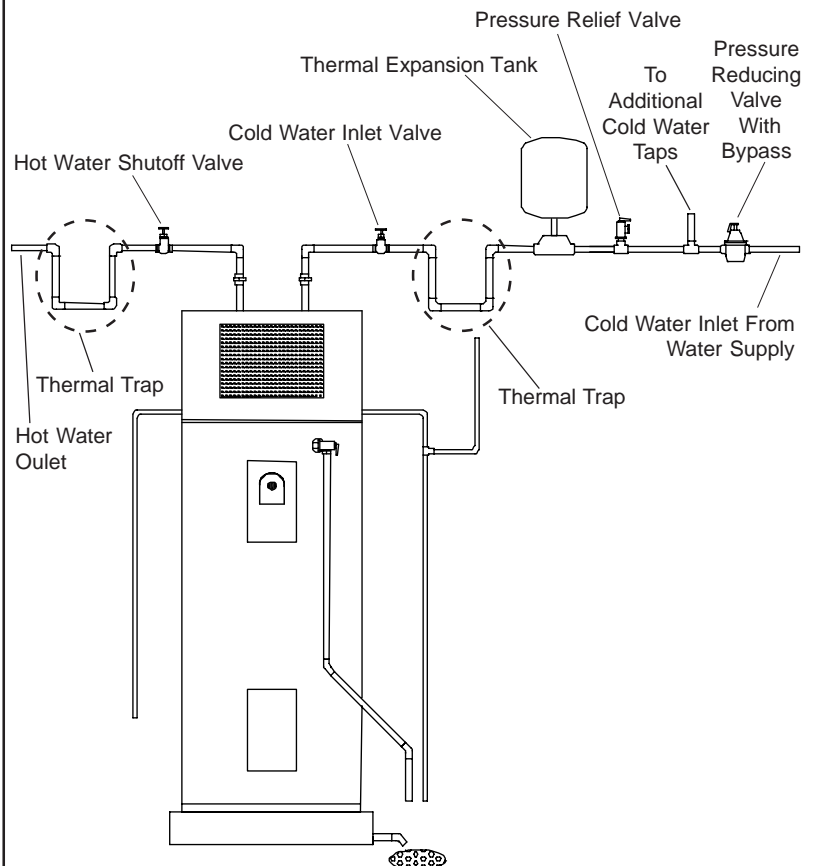

IMPORTANT: Always use a good grade of joint compound and be certain that all fittings are drawn up tight.

1. Install the water piping and fittings as shown in Figure 3 by connecting the cold water supply to the fitting marked “C” and the hot water piping to “H.”

2. The installation of unions and water shutoff valves in both the hot and cold water supply lines is recommended for easy removal of the unit if service or replacement is required. (Figure 3)

3. The manufacturer recommends installing a tempering valve in the domestic hot water line of the unit. This valve reduces the point of use temperature of the hot water by mixing cold and hot water. (Figure 4)

4. If installing the WatterSaver™ in a closed water system, install a relief valve or expansion tank in the cold water line as specified under “Closed System/Thermal Expansion.” (Figure 3)

NOTE: The manufacturer recommends installing thermal traps to reduce the effects of stacking (see page 10) and Figure 3

FIGURE 4- Tempering Valve Connections

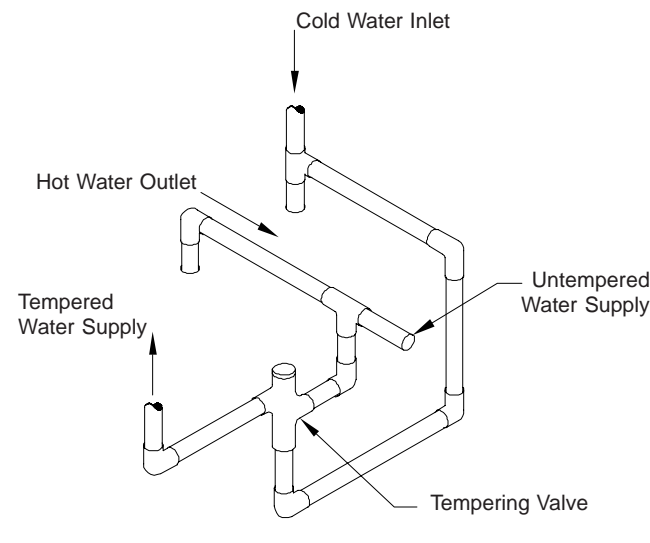

5. Install a shutoff valve in the cold water inlet line. It should be located close to the water heater and be easily accessible. Know the location of this valve and how to shut off the water to the heater.

6. Install a discharge line in the temperature and pressure relief valve as specified in these instructions. (Figure 2)

7. After piping has been properly connected to the water heater, open all hot water faucets and the cold water supply valve to the tank and allow the tank to completely fill with water. To purge the lines of any excess

air and sediment, keep the hot water faucet open for 3 minutes after a constant flow of water is obtained. Close the faucet and check all connections for leaks.



Water supply to the WatterSaver™ must not exceed 180° F. Water temperatures in excess of 180° F will cause the high temperature cutout switch to shut off power to the unit. The high temperature cutout switch must be reset before the water heater can be operated.

IMPORTANT: Remember to install a suitable drain pan under the water heater and pipe the drain line to an adequate drain.



Do not operate the WatterSaver™ with the cold water shutoff valve closed. This can result in serious damage to the water tank and will void the warranty.

ELECTRICAL CONNECTIONS



Do not apply power to an empty or partially filled water heater. This can result in serious damage to the tank and destroy the heating elements and will void the warranty.

When making electrical connections, always make sure:

- The electrical supply has the proper overload fuse or breaker protection.
- Wire sizes and connections comply with all applicable codes.
- Wiring is enclosed in an approved conduit (if required by local codes).
- The water heater and electrical supply are properly grounded.

If you lack the necessary skills required to properly install the WatterSaver™, **DO NOT PROCEED**. Have a qualified electrician perform the installation.

DO NOT USE AN EXTENSION CORD TO SUPPLY POWER TO THE WATTERSAVER™ HEAT PUMP WATER HEATER.

IMPORTANT: *Figures 5 and 6* are provided as reference drawings for the 208/240V 2-wire models only. Always reference the wiring diagram on the water heater for the correct electrical connections.

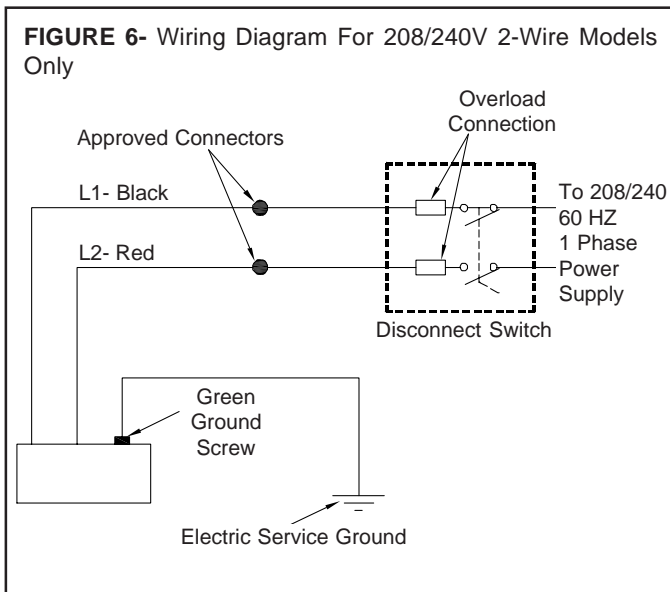
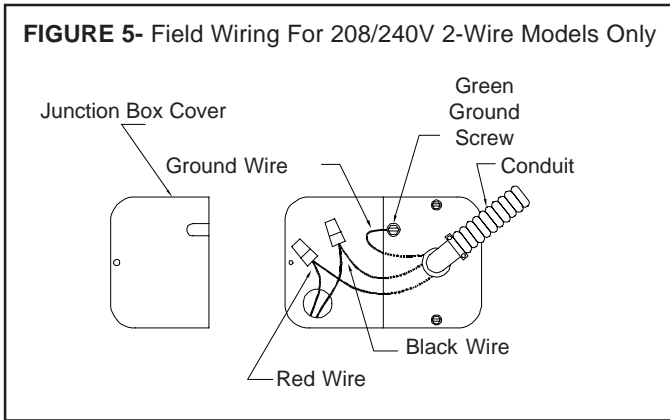

⚠ CAUTION ⚠

Applying electric power to elements that are not submerged in water will destroy them. The manufacturer will not warranty any elements damaged in this manner.

WHEN INSTALLING THE ELECTRICAL WIRING TO THE WATER HEATER:

1. Be sure tank is completely filled with water before making any electrical connections.
2. Shut off the power source to the unit.
3. Loosen the screw holding the junction box cover to the top of the water heater. Set the cover aside.
4. Make the electric connections to the water heater in accordance with local utility requirements and codes. A standard 1/2" opening has been made in the junction box for conduit connections.
5. Ground the water heater by connecting a grounding wire from the electric service ground terminal to the green grounding screw in the junction box of the water heater.

INSTALLATION CHECKLIST

WATER HEATER LOCATION

- Centrally located in relation to the water piping system.
- Located indoors in a vertical position and protected from freezing temperatures.
- Area protected from water damage.
- Drain pan properly installed and piped to an adequate drain.
- Sufficient room to maintain or service the water heater.

WATER SYSTEM PIPING

- Properly installed and free of leaks.
- Temperature and pressure relief valve properly installed.
- Condensate drains (primary and secondary) piped.
- Discharge line run to an open drain and protected from freezing.
- Heater completely filled with water.
- Closed system pressure build-up precautions installed.
- Tempering valve installed per manufacturer's instructions if required.

ELECTRICAL CONNECTIONS

- Wiring and connections comply with all applicable codes.
- Water heater and electric supply properly grounded.
- Proper overload fuse or breaker protection installed.

START-UP AND OPERATION



DO NOT attempt to operate or repair this water heater if the thermostat or surrounding insulation has been exposed to water in any way. Call a qualified service technician to inspect the unit and immediately replace any thermostat or insulation that has been exposed to water.

Water heaters subjected to flood conditions or thermostats that have been submerged in water require replacement of the entire water heater.

EMERGENCY SHUT-OFF

A high temperature cutout switch on the WatterSaver™ will automatically shut the unit off in the event that water temperature exceeds 180° F (83° C). The high temperature cutout switch can be reset by firmly pushing the red reset button located behind the thermostat panel on the front of the unit.

IMPORTANT: The water temperature must be below 180°F (83° C) in order to reset the unit.

IMPORTANT: Be sure the water tank is completely filled before applying electrical power to the unit.

1. To ensure the unit is completely filled, open all hot water faucets to allow air to escape from the piping. Then close the faucets, turn on the power supply, and rotate the temperature selector dial to the desired setting.
2. The upper electric resistance element (represented by a green LED located inside the front grille of the WatterSaver™ shroud) will turn on after a brief delay and turn off when the upper temperature sensor is satisfied.

3. When the green LED turns off, the yellow LED will glow and the compressor and fans will energize. The heat pump will operate until the lower temperature sensor is satisfied.

IMPORTANT: There will be a brief time delay between compressor start-up and when the fans begin to run.

4. When the heat pump stops running, the LEDs will stop glowing. At this point, the water has reached the set temperature.

QUICK REFERENCE- The LED indicators inside the front grille of the WatterSaver™ shroud represent:

- **Green** – Upper electric resistance element
- **Yellow** – Compressor
- **Red** – Lower electric resistance element

WATER HEATER OPERATION

1. When there is a demand for hot water, cold water (from the water supply), enters the tank, travels down the dip tube, and is delivered to the bottom of the tank.

2. The lower temperature sensor reacts to the decreased tank temperature and energizes the heat pump.

3. The heat pump will continue to operate until the water temperature reaches the thermostat setting.

IMPORTANT: When the heat pump is running, the unit will emit sounds similar to a refrigerator or dehumidifier.

4. If the demand for hot water is greater than the recovery rate of the heat pump, the upper temperature sensor will react to the decreased upper tank temperature, turn off the heat pump and energize the upper electric resistance element. The mode of operation is indicated by the LED indicators.

IMPORTANT: **In the event of heat pump system failure or extreme ambient (hot or cold) conditions, the red LED will glow. Refer to *Troubleshooting Guide* for more information.**

WATER TEMPERATURE REGULATION

The thermostat is adjusted to a temperature setting of 120° F or lower when it is shipped from the factory. Water temperature can be regulated by adjusting the thermostat to the preferred setting as shown in *Figure 7*.

The preferred starting point is 120° F. There is a hot water scald potential if the thermostat is set too high.

FIGURE 7- Approximate Thermostat Settings

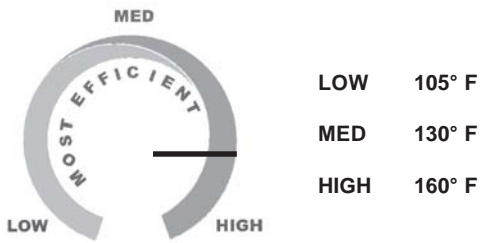

NOTE: Temperature settings beyond the black indicator will result in decreased efficiency, due to increased operation in electric resistance mode.



Adjusting the thermostat past the “MEDIUM” setting on the dial will increase the risk of scald injury.

During low demand periods when hot water is not being used, a lower thermostat setting will reduce energy loss and may satisfy your hot water needs. If hot water use is expected to be more than normal, a higher setting may be required to meet the increased demand.

When leaving your home for extended periods, turn the thermostat to its lowest setting. This will maintain the water at low temperatures with minimum energy loss and prevent the tank from freezing during cold weather.



Hot water can produce first degree burns within 3 seconds at 140° F (60° C), 20 seconds at 130° F (54° C), or 8 minutes at 120° F (49° C).

Installing an anti-scald device in the hot water supply line will reduce the risk of scald injury.

Households with small children, elderly or disabled members, or anyone with sensitive skin may require a lower temperature setting to reduce the risk of scalding.

OPERATIONAL CONDITIONS

WATER ODOR

The water supply system may require special filtration equipment from a water conditioning company to successfully eliminate all water odor problems.

Each WatterSaver™ contains an anode rod which slowly dissipates while protecting the tank from corrosion. Certain water conditions will cause a reaction with the rod, the most common being a “rotten egg smell” caused by hydrogen sulfide gas dissolved in the water.

WATER HEATER SOUNDS

During normal WatterSaver™ operation, certain noises will be heard. These noises are common and may result from:

- Operation of compressor and fans.

IMPORTANT: Fan cycling may occur when ambient temperatures are high.

- Normal expansion/contraction of metal parts during heat-up and cool-down.
- Sediment build-up on the tank bottom or scale and mineral deposits on the heating elements.



Hydrogen gas can be produced in a hot water system that has not been used for a long period of time (usually two weeks or more). Hydrogen gas is extremely flammable and can ignite when exposed to a spark or flame.

To prevent the possibility of injury under these conditions, open the hot water faucet at the nearest sink for several minutes before using any electrical appliance connected to the hot water system. If hydrogen gas is present, you will probably hear a sound like air escaping through the faucet as water begins to flow.

Do not smoke or have any open flame near the faucet when it is open!!!



Do not operate the WatterSaver™ without the anode rod installed. This will void the warranty.

STACKING

Stacking occurs when many short draws of hot water (3 gallons or less) are taken from the water heater tank over a period of time, this results in increased cycling of the water heater which will increase the water temperature at the hot water outlet.

WATER HEATER MAINTENANCE

CLEANING THE WATERSAVER™

• The air filter should be cleaned at least twice a year or whenever it is visibly dirty. A dirty filter reduces air flow to the heat pump's evaporator coil, resulting in decreased efficiency. To clean the filter, remove it from the shroud by pulling it away from the hook fasteners. then vacuum it or wash it in warm water with a mild soap and pat it dry before replacing it.

• The outer surfaces of the WaterSaver™ Heat Pump Water Heater may be cleaned with a sponge and warm soapy water. Do not use bleach, abrasive cleaners, or solvents which will damage the unit's finish.

DRAINING AND FLUSHING

The WaterSaver™ should be drained completely if being shut down in freezing temperatures. It is recommended that the water tank be flushed every 6 months to remove sediment that builds up during operation. To drain and flush this water heater:

1. Disconnect power to the unit.
2. Close the cold water inlet valve and open a nearby hot water faucet.
3. Connect a hose to the drain valve and terminate it at an adequate drain.
4. Open the drain valve and allow the tank to drain, periodically opening and closing the cold water inlet valve to flush sediment from the tank.
5. When clear water is observed coming from the drain hose, close the drain valve and disconnect the hose.
6. Open the cold water inlet valve to refill the tank with water.

7. Close the hot water faucet when water begins flowing from it.

8. Restore power to the unit.

9. Refer to "Start Up Procedures" in this manual.

IMPORTANT: If the water heater is going to be shut down for an extended period, the drain valve should be left open.



Water draining from the WaterSaver™ Heat Pump Water Heater will be hot and can result in an injury by scalding. Do not allow anyone to come in contact with draining water!!

ROUTINE INSPECTION

ACTION	EVERY			
	3 MOS	6 MOS	9 MOS	1 YR
Check for Leaking or Damaged Water Piping	X	X	X	X
Check for Proper Ground Connection and Frayed or Loose Wiring	X	X	X	X
Check for Presence of Flammable Materials in the Installation Area	X	X	X	X
Drain and Flush Tank		X		X
Clean Air Filter		X		X



Sediment build-up and mineral deposits may cause premature tank failure. Drain and flush the tank as noted under "Draining and Flushing" in these instructions.

WATERSAVER™ TROUBLESHOOTING GUIDE

UNIT DOES NOT TURN ON AFTER WIRING IS COMPLETE

Insufficient Power From Breaker. Verify 208/240 VAC power source with a 30 amp breaker.

Breaker In "OFF" Position. Turn breaker to "ON" position.

Wiring May Be Incorrect. Verify wiring with wiring diagram.

High Temperature Cutout Switch Is Open. Reset high temperature cutout switch by removing top element cover and pushing the red "reset" button until it clicks.

Defective Control Board. Replace control board.

Defective High Temperature Cutout Switch. Replace high temperature cutout switch.

COMPRESSOR WILL NOT TURN ON

Manual Bypass Switch On Control Board Is In The “Elec” Position. Switch manual bypass switch to the “HP” position.

Ambient Conditions Outside Heat Pump’s Operating Range. Heat pump designed to operate in ambient conditions above freezing.

Wiring May Be Incorrect. Verify wiring with wiring diagram.

HIGH TEMPERATURE CUTOUT SWITCH ACTIVATED

Defective Upper Or Lower Temperature Sensors - Replace temperature sensor(s).

Defective High Temperature Cutout Switch - Replace high temperature cutout switch.

Defective Control Board - Replace control board. (See warranty)

Wiring Of Upper Or Lower Temperature Sensor May Be Incorrect - Verify wiring with wiring diagram.

Stacking - See Stacking on page 10.

EVAPORATOR FROSTING OR ICING

Defective Evaporator Temperature Sensor. Replace evaporator temperature sensor.

Loss Of Refrigerant Charge/Leak In Heat Pump System. Repair leak and reprocess heat pump system with 16 ounces of R134A. (See warranty)

Defective Thermoexpansion Valve (TXV). Replace TXV. (See warranty)

Poor Air Flow. Ensure operation of both fans, verify evaporator coil and air filter are not dirty, and make sure airflow to inlet or outlet is not blocked.

IMPORTANT: Fan cycling may occur in ambient conditions greater than 90 F.

T&P VALVE DRIPPING

System Pressure Too High. Decrease system pressure.

Improperly Seated T & P Valve Seal. Refer to “T & P valve” on page 5 of this IOM.

Defective T & P valve. Replace T & P valve.

NO HOT WATER

Insufficient Power To Unit. Verify power supply.

Defective Upper Electrical Element. Replace upper electrical element.

Defective Thermostat. Replace thermostat.

Defective Control Board. Replace control board.

Defective Upper Temperature Sensor. Replace upper temperature sensor.

High Temperature Cutout Switch Is Open. Reset high temperature cutout switch by removing top element cover and pushing the red “reset” button until it clicks.

INSUFFICIENT HOT WATER

Defective Temperature Sensors. Replace temperature sensors.

Thermostat Too Low. Increase thermostat setting.

Unit Undersized For Application. Install adequately sized water heater.

Defective Upper Element. Replace upper element.

Piping Is Incorrect. Refer to “Piping Installation” on page 6 of this IOM.

Long Runs Of Exposed Piping Or Hot Water Piping In Exposed Wall. Insulate piping.

Sediment Or Lime In Tank. Flush tank as described on page 11 of this IOM.

Leaking Faucets. Repair faucets.

Loss Of Charge. See warranty.

SLOW HOT WATER RECOVERY

Defective Upper Electrical Element. Replace upper electrical element.

Defective Control Board. Replace control board.

Defective Upper Or Lower Temperature Sensors. Replace temperature sensor(s).

Loss Of Charge. See warranty.

WATER ODOR

Sulfides In Water. See “water odor” on page 10 of this IOM.

RED LED GLOWING

Manual Bypass Switch On Control Board Is In The “Elec” Position. Switch manual bypass switch to the “HP” position.

Ambient Conditions Outside Of Operating Range. Move water heater to more suitable location.

Lower Tank Heat Is Called For Within Six Minutes Of A Previous Compressor Shutdown. Allow a minimum of six minutes between restarts.

Heat Pump System Failure. Consult factory.

HIGH OPERATING COSTS

Manual Bypass Switch On Control Board Is In The “Elec” Position. Switch manual bypass switch to the “HP” position.

Thermostat Too High. Lower thermostat into the “most efficient” range of the temperature indicator label.

Unit Undersized For Application. Install adequately sized water heater.

Loss Of Charge. See warranty.

HEATING ELEMENT REPLACEMENT



Heating element removal and replacement involves the disconnection of electrical wiring. The following procedures must only be performed by a qualified service technician.

Replacement heating elements must be the same style and voltage/wattage rating as what is presently found in the water heater. This information can be found on the flange or terminal block of the element or on the unit rating plate.

1. Shut off electric power to the water heater.
2. Drain the water heater as directed under “Draining and Flushing.”
3. Remove the access cover and fold the insulation outward and away from the heater element(s). Remove the plastic thermostat cover from the thermostat, making sure to disengage the attachment point from the thermostat.
4. Disconnect the electric wires from the heating element (*Figure 8*) and remove the screw-in elements by turning the element counterclockwise with a 1-1/2 inch socket wrench. Remove the existing gasket.

5. Clean the area where the gasket fits to the tank. If you are replacing the bottom element, remove the accumulated sediment on the bottom of the tank.

6. Make sure the replacement element has the correct voltage and wattage rating. Position the new gasket on the element and insert it into the water heater tank (*Figure 9*). Tighten the element by turning it clockwise until secure.

7. Close the drain valve. Open all hot water faucets and allow the tank to fill completely with water. To purge the lines of any excess air and sediment, keep the hot water faucet open for 3 minutes after constant flow of water is obtained.

8. Close the faucet and check all connections for leaks. Check for leaks around the element(s).

9. Connect the electric wires to the heater element. Make sure the wires are secure and the attachment points are engaged on the thermostat.

10. Replace the plastic thermostat cover, insulation, and the access cover(s).

11. Make certain the tank is filled with water. Applying electric current to heater elements not submerged in water will destroy them.

12. Restore the electric power supply to the water heater.

WATERSAVER™ COMMON REPLACEMENT PARTS

Temperature Sensor
Connections on
Control

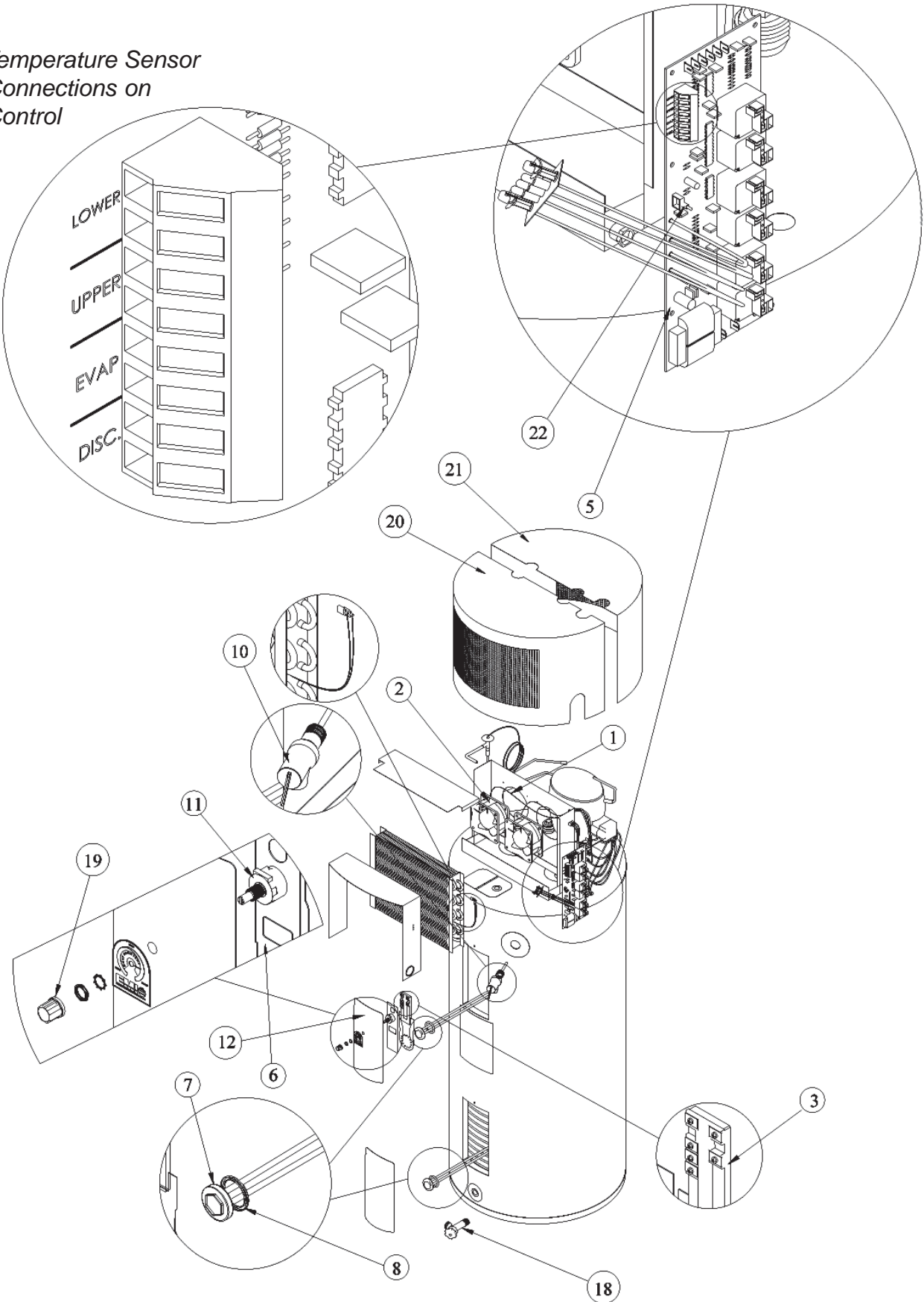

WATERSAVER™ COMMON REPLACEMENT PARTS

PART NUMBER	DESCRIPTION
1 240-0817	24" FAN CORD
2 240-3192	230V HPWH FAN
3 240-3653	HIGH TEMPERATURE CUTOUT SWITCH
4 240-3289	CONTROL BOARD SUPPORT (NOT SHOWN)
5 240-4177	CONTROL BOARD
6 240-3665	UPPER ELEMENT COVER
7 240-3645	ELECTRICAL ELEMENT
8 240-3646	ELEMENT GASKET
9 240-3647	DIP TUBE (NOT SHOWN)
10 240-3648	TEMPERATURE AND PRESSURE RELIEF VALVE (T&P VALVE)
11 240-3556	TEMPERATURE CONTROLLER
12 240-3659	ACCESS DOOR
13 240-3644	ANODE ROD (NOT SHOWN)
14 240-3229	EVAP TEMPERATURE SENSOR (NOT SHOWN)
15 240-3770	DISCHARGE TEMPERATURE SENSOR (NOT SHOWN)
16 240-3771	UPPER TANK TEMPERATURE SENSOR (NOT SHOWN)
17 240-3772	LOWER TANK TEMPERATURE SENSOR (NOT SHOWN)
18 240-3650	DRAIN VALVE
19 240-3557	TEMPERATURE CONTROLLER KNOB
20 240-4279	FRONT TOP COVER
21 240-4280	REAR TOP COVER
22 N/A	ELEC/HP TOGGLE SWITCH

NOTE: FOR INQUIRIES ON PARTS NOT LISTED, PLEASE CONTACT THE FACTORY .

FIGURE 8- Disconnecting Electric Wires From the Heating Element

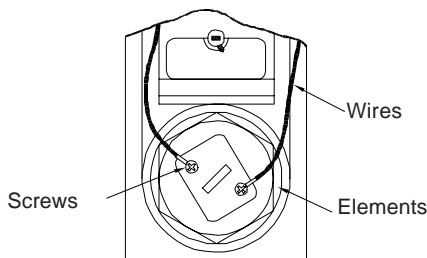
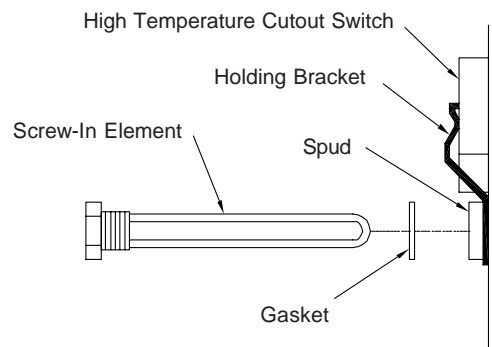

FIGURE 9- Replacing the Heater Element



MEA# 067-01-E

ECR International

Manufactured by:
 ENVIROMASTER INTERNATIONAL LLC
 5780 Success Drive, Rome, NY 13440
 Email: emi@enviromaster.com
 Web: <http://www.enviromaster.com>

