



Comfort Where It Counts.

DCHC365 (CAH36-SCC36)

Rev. 1.2 [1/05]

JOB NAME: \_\_\_\_\_ LOCATION: \_\_\_\_\_  
PURCHASER: \_\_\_\_\_  
ENGINEER: \_\_\_\_\_  
SUBMITTED TO: \_\_\_\_\_ FOR: REFERENCE [ ] APPROVAL [ ] CONSTRUCTION [ ]  
SUBMITTED BY: \_\_\_\_\_ DATE: \_\_\_\_\_  
UNIT DESIGNATION: SCHEDULE #: \_\_\_\_\_ MODEL #: \_\_\_\_\_

▲▼ CAPACITIES

Cooling 35,000 Btu

Indoor Design Temp °F DB/WB

Cooling 80/67

Outdoor Design Temp °F DB/WB

Cooling 95/75

EER 10

SEER 10

▲▼ INDOOR UNIT

Power Supply 208/230/1/60

Max. Fuse Size 30 Amps (w/5KW Electric Heat)

Min. Ampacity 28.3 Amps (w/5KW Electric Heat)

Sound 48 dB(A) High

45 dB(A) Low

Weight 128 Lbs.

▲▼ OUTDOOR UNIT

Power Supply 208/230/1/60

Max. Fuse Size 30 Amps

Min. Ampacity 19.8 Amps

Sound 67.2 dB(a)

Weight 155 Lbs.

▲▼ REFRIGERANT PIPING

Max. Lift 35 Ft.

Max. Total Interconnect 100 Ft.

Liquid (OD) 3/8 In.

Suction (OD) 7/8 In.

▲▼ STANDARD FEATURES

- Five-Year Compressor/One-Year Parts Warranty
- Anti-Short Cycle Protection
- Fan Purge
- Side Discharge/ Condenser Low Profile
- Condensate Pump w/18" Lift
- High Pressure Switch
- Fresh Air Knockouts For Outside Fresh Air Intake
- Branch Duct Knockouts For Remote Discharging
- Motorized 4 Way Adjustable Air Supply Louvers

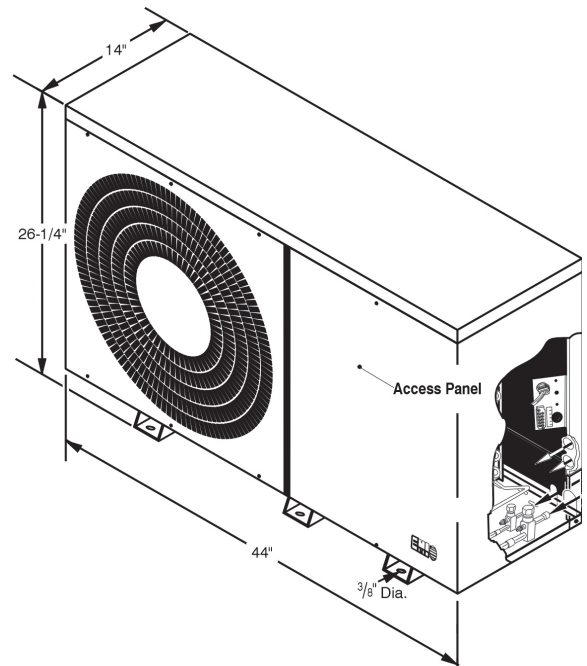
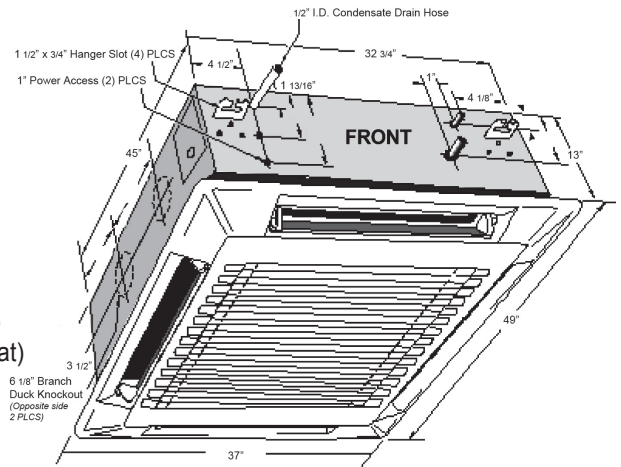

EMI ENGINEERING SUBMITTAL

▲▼ **PART ONE- "GENERAL"**

The Straight Cool air conditioning system shall be an EMI AmericaSeries split system. The system shall consist of a cassette ceiling mounted packaged evaporator section Model CAH36 and matching AmericaSeries outdoor unit Model SCC36. The units shall be made within North America. The units shall be listed by Intertek Testing Service (ITS) and bear the ETL label. All wiring shall be in accordance with the National Electrical Code (N.E.C.). The units shall be rated in accordance with ARI Standard 210/240. The units shall be manufactured in a facility certified to ISO 9001, which is an international standard used to provide guidance in the development and implementation of an effective Quality Management System. The condensing unit shall contain an R-22 refrigerant charge for the evaporator section and condenser section. System SEER shall meet or exceed 1992 Federal Standards.

▲▼ **PART TWO- "WARRANTY"**

The units shall have a manufacturer's warranty for a period of one (1) year from date of installation. The compressor shall have a warranty of five (5) years from date of installation. If, during this period, any part should fail to function properly due to defects in workmanship or material, it shall be replaced or repaired at the discretion of Enviromaster International LLC. This warranty does not include labor. Manufacturer shall have fifteen years experience in the U.S. market.

▲▼ **PART THREE- "PERFORMANCE"**

Each indoor unit shall provide a total minimum cooling capacity of 35,000 Btuh with a SEER of 10 and an EER of 10 at ARI standard conditions. The system net minimum total cooling capacity shall be 35,000 Btuh and the net minimum sensible cooling capacity shall be 20,450 Btuh with a circulating air rate of 890 CFM at 80° F (DB) / 67° F (WB) entering the indoor coil and 95° F (DB) air entering the outdoor coil. The total power consumption of the combined system shall not exceed 3,500 Watts at these conditions.

▲▼ **PART FOUR- "INDOOR UNIT"**

The indoor unit shall be factory assembled, wired and contain a low voltage transformer. The indoor unit shall consist of galvanized steel chassis with fire-resistant thermal and acoustic foam insulation and pearl grey high-impact polystyrene fascia. This unit shall fit in the ceiling and have the capability of attaching a branch supply duct as well as a fresh air duct. The evaporator fans shall be backward curved impeller centrifugal design, dynamically and statically balanced, and mounted on integral mounting rails. The evaporator motors shall be multispeed, enclosed type with thermal protection and sealed lifetime bearings. The indoor unit shall have factory installed 5KW electric heat. The indoor unit shall be equipped with a TXV at the coil and shall have motorized 4-way adjustable air supply louvers. Return air shall be filtered by means of an easily removable filter. The evaporator coil shall be of nonferrous construction with louvered fins bonded to rifled copper tubing. The tubing shall have inner grooves for high efficiency heat exchange. All tube joints shall be brazed with phoscopper or silver alloy. The coil shall be pressure tested at the factory. A condensate pan and drain shall be provided under the coil. An integral condensate pump capable of lifting 18 inches shall be provided. The unit electrical power shall be 208/230 Volts, 1 phase, 60 Hertz. The system shall be capable of satisfactory operation within voltage limits of 208/230 +/- 10% Volts.

▲▼ **PART FIVE- "CONTROL SYSTEM"**

The control system shall consist of connections for a 24V Wall Thermostat Control; anti-short cycle compressor protection; fan purge; 60 second post-purge fan relay after heat/cool call is dropped (for improved efficiency); integral heating relay to ensure that the fan operates whenever electric heat is energized; and two-stage heating capability when matched up with an EMI heat pump and an appropriate two stage thermostat. Wiring shall run from indoor unit to the 24V wall thermostat and to outdoor unit with **NO SPLICES**. When running low voltage wiring, a double insulated 18 awg wire should be used. The control voltage between the indoor unit and the outdoor unit shall be 24 Volts A.C. The 24 Volts shall be generated from the indoor unit's 24 Volt 40VA transformer.

▲▼ **PART SIX- "OUTDOOR UNIT"**

The outdoor unit shall be completely factory assembled, piped and wired. The cabinet shall be fabricated of G60 galvanized steel, finished in "off-white" with corrosion inhibiting polyester powder-coated paint. The unit shall be furnished with one (1) direct drive, propeller type fan arranged for horizontal discharge. The motors shall have inherent protection, be of the permanently lubricated type, and resiliently mounted for quiet operation. The fans shall be provided with a guard to prevent contact with moving parts. The compressor shall be of the high-performance reciprocating type with a thermal overload. The compressor shall be mounted so as to avoid the transmission of vibration. The refrigeration system shall be equipped with a high pressure switch and have the capability to operate with a maximum height difference of 35 feet and overall refrigerant tubing length of 100 feet between indoor and outdoor sections without the need for line size changes or additional oil. The condenser coil shall be of nonferrous construction with smooth louvered bonded to copper tubing. The unit shall be controlled by an electronic circuit board located in the indoor matching unit. The unit electrical power shall be 208/230 Volts, 1 phase, 60 Hertz. The system shall be capable of satisfactory operation within voltage limits of 208/230 Volts +/- 10%.

▲▼ **PART SEVEN- "OPTIONAL EQUIPMENT"**

- Infrared Microprocessor Control (factory installed only)
- Hydronic Heat (factory installed)
- Low Ambient Control (consisting of a fan cycle switch; field installed)
- Hard Start (field installed)
- Sea Coast Style Coated Coils (coating shall protect against corrosion due to acids, solvents and salt; factory installed)
- Fresh Air Duct Collar
- Wall Thermostat



5780 Success Drive, Rome, NY 13440  
Phone: 1-800-228-9364  
FAX: 1-800-232-9364  
Email: emi@enviromaster.com