

WLCG/WLHG

R-410A High-Efficiency Ductless Split System
High-Wall Air Handlers

EMI *AmericaSeries*
Comfort Where It Counts.

Straight cool / Heat pump nominal capacities			
WLHG09	WLHG12	WLHG24	Units
9,000	12,000	18,000 - 23,800	Btuh
2.6	3.5	5.3 - 7.0	kW
Straight cooling only — nominal capacity			
WLCG30			Units
28,200			Btuh
8.3			kW

Specifications and Performance

(with EMI AmericaSeries condensers)



WLCG/WLHG

ECR International LLC
5780 Success Drive
Rome, NY 13440
www.enviromaster.com
email: info@enviromaster.com



innovative living™
An ISO 9001-2000 Certified Company



NOTICE

EMI AmericaSeries air handlers and condensers are backed by EMI and ECR International and are tested, rated and certified in accordance with ARI Standard 210/240 and UL-1995. Due to ongoing product development, product designs and specifications may change without notice. Please contact the factory for more information.

WLCG/WLHG Air Handlers — Product Description

Product description

- The AmericaSeries WLCG/WLHG is available as a (DX) direct expansion straight cool and heat pump.
- It offers a contemporary design in a ductless type Air Handler and combines attractive appearance with high efficiency conditioning for small to medium size commercial or residential spaces.
- The WLCG/WLHG is equipped with unit mounted infrared compatible controls which also supports 24V remote wall thermostat operation. Optional handheld remote is available.
- Heat pump models provide up to 24,000 Btuh of cooling and 20,600 Btuh of heating. Electric heat options are available for up to 5 kW of supplemental heat.
- This American-made evaporator offers ease of installation, operation, and service.
- It can be matched with EMI's:
 - Single-zone condensing units — S1CG/S1HG 9,000-24,000 Btuh and S1CG 30,000 Btuh.
- All EMI air handlers are backed by Enviromaster International LLC and are tested, rated and certified in accordance with ARI standards 210/240 and UL 1995.



Controls and components (Factory-installed or supplied)

- Large LCD Backlit Display
- Single unit-mounted control package, configurable to either unit mount or remote wall thermostat operation, increasing installation flexibility.
- Unit control can be used in cooling only, cooling with electric heat, heat pump, or heat pump with second stage electric heat applications.
- Operational range set point temperature adjustable between 55°F and 90°F (13 to 32°C) in one-degree increments.
- Infrared-compatible controller allows use of optional IR hand held controller. NOTE: Unit-mounted controls are fully functional without the handheld remote.
- Operation modes include Heat, Cool, Dry, Fan and Auto Change-over.
- Fan Operation – Auto/On. High or Low speed fan
- Fan Purge – Fan remains on for 60 seconds after Heat/Cool call is dropped for improved efficiency (Auto mode only)
- Room air sampling — Selectable time intervals ensure the fan will cycle on periodically in Auto Fan Mode to help eliminate room temperature stratification.
- Selectable Fahrenheit (°F) or Celsius (°C) temperature scale.
- Dry mode – Operates cooling and electric heat simultaneously to remove humidity. Optional electric heat must be selected.
- Anti-Short Cycle Compressor Protection.
- Minimum on time for heating and cooling Helps eliminate room temperature drop and system short cycling.
- Freeze Protection – Prevents evaporator freeze up.
- Test operation – Allows ease of testing after installation (all timers are reduced).
- Non-volatile back-up memory will maintain control settings for an indefinite period during a power outage. When power is restored the equipment will resume operation after a three-minute compressor time delay.
- 7 day, 4 event programmable with copy feature.
- Filter change indicator: A timer feature indicates when the filter should

be cleaned according to the selected time.

- Motorized supply louver with optional sweep or six stationary settings.
- Modular design – reduces parts required for control package. Deco panel, relay board, ribbon cables and microprocessor are combined into one package.
- Integral condensate pump safety-switch connection where-by the microprocessor monitors the condensate pump safety switch and displays an error code when a fault occurs. (Applies only with field installed condensate pump)
- CEC (California Energy Commission) compliant
- Condensate drain pan over flow protection.
- Staggered Start

Cabinet features:

- Durable ABS plastic cabinet with a galvanized steel sub-chassis.
- Easily accessible, washable, reusable, nylon mesh filter.
- Horizontal discharge louver, constructed of high temperature ABS plastic, that can be set to oscillate, or can be parked in six pre-set positions.
- Manually adjustable vertical discharge fins.
- Easy access to pipe chase area from cabinet bottom allows piping connections and condensate pump installation with the unit mounted on the wall.
- Easily removable end-cap for access to control area for installation and service.
- Condensate drain pan constructed of galvanealed steel with anti-corrosion coating.

Optional equipment

- Condensate pump (field installed only).
- 24V remote wall thermostat.
- Electric heat with automatic reset high temperature cutout and redundant high temperature fuse link (when heat option is selected) 208/230V only.
- Hand-held infrared controller.

Installer-supplied Items

- Low voltage wiring (Minimum 18 AWG required)
- High voltage power supply wiring
- Mounting screws and fasteners
- Condensate piping
- Refrigerant piping (if not supplied)
- Refrigerant (for interconnect charge)
- Electrical Disconnect High Voltage

Table 1 Discharge air speed and flow @ 230 VAC / Sound values

Model	High speed CFM (l/s)	Low speed CFM (l/s)	Coil	FPM (m/s)	Throw feet (m)	Observed sound values (dBA)
WLHG 09-12	400 (190)	350 (170)	Dry	900 (4.6)	15 (4.6)	45
WLHG24	750 (350)	675 (320)	Dry	1,225 (6.2)	25 (7.5)	56
WLHG30	1,100 (520)	900 (420)	Dry	1,250 (6.4)	27 (8.2)	60

WLCG/WLHG Air Handlers — Product Description *(continued)*

Figure 1 WLCG/WLHG ductless air handlers — dimensions

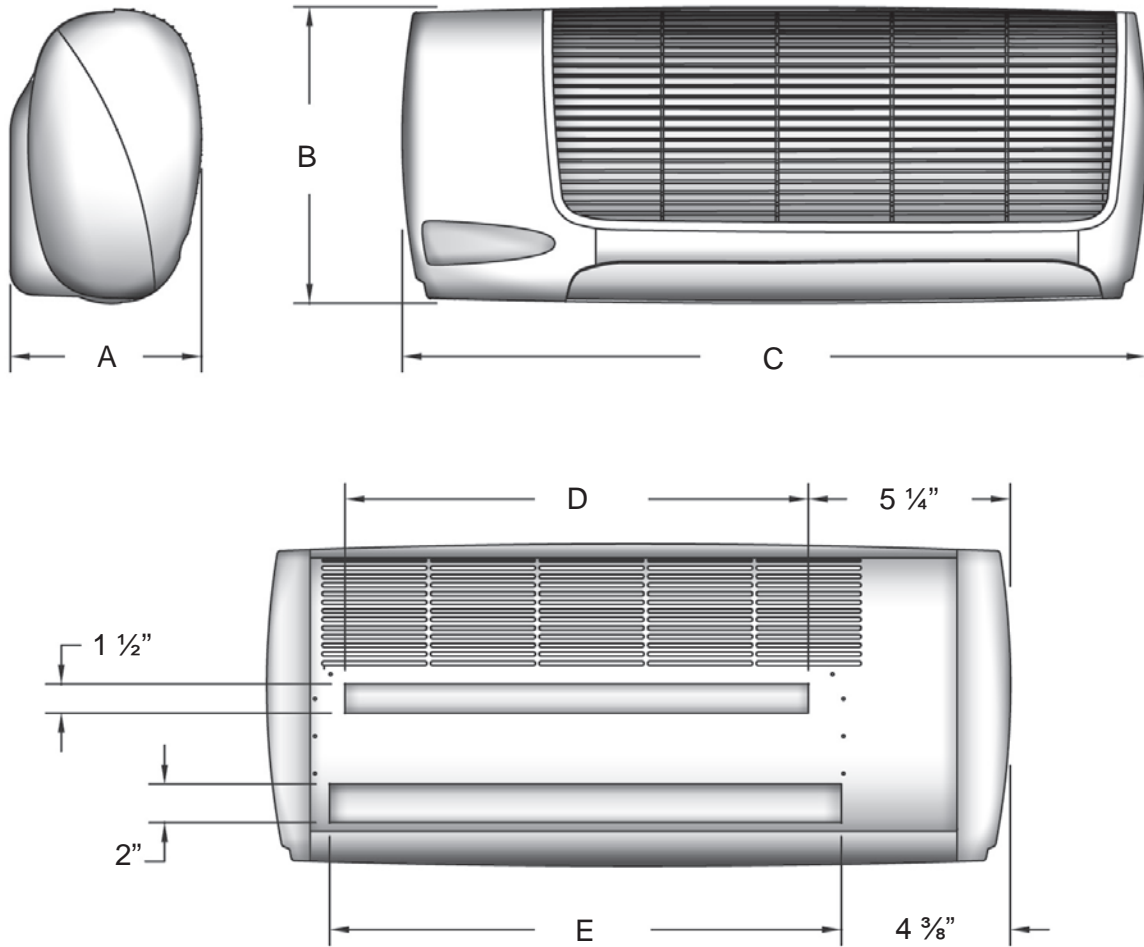

Model	A	B	C	D	E	Shipping weight
	Depth in (mm)	Height in (mm)	Length in (mm)	Mounting bracket clearance in (mm)	Tubing access clearance in (mm)	Pounds (kg)
WLHG09	9 7/8" (251)	15 1/4" (387)	38 1/2" (978)	24" (610)	26 1/2" (673)	58.0 (26.4)
WLHG12	9 7/8" (251)	15 1/4" (387)	38 1/2" (978)	24" (610)	26 1/2" (673)	60.3 (27.4)
WLHG24	9 7/8" (251)	15 1/4" (387)	48 1/2" (1232)	34" (864)	36 1/2" (927)	66.2 (30.0)
WLCG30	9 7/8" (251)	15 1/4" (387)	58 1/2" (1486)	44" (1118)	46 1/2" (1181)	90.1 (40.9)

WLCG/WLHG Air Handlers with S1CG/S1HG Condensers

S1CG/S1HG — description

The AmericaSeries S1CG/S1HG condensing units are air-cooled, vertically-arranged side-discharge, high-efficiency units designed specifically to meet or exceed a 13 SEER rating.

- The S1CG Models 9,000-36,000 Btuh and S1HG Models 9,000-24,000 Btuh condensing units will provide cooling and heating for a single evaporator.
- The S1CG/S1HG are quiet units that can be recommended for both commercial and residential applications.

NOTICE

When specifying heat pump(s), it is recommended that the matching indoor unit(s) be equipped with electric heat.

Features

- Installation of the S1CG/S1HG condensing units is simplified by a 24v control interconnection from the evaporator.
- Multiple units can be lined up in close proximity to an exterior wall.
- Service valves are recessed to reduce tampering.
- All 9,000–12,000 Btuh units are equipped with a an oversized suction accumulator with surge baffles and enhanced oil management and a factory-installed solid core filter drier.
- A factory-installed crankcase heater is standard on S1HG 9,000-12,000 Btuh (thermostatically-controlled) and is available as optional equipment on other models.

Controls and components (Factory-installed or supplied)

- Compressor and fan motor contactor
- Run capacitor
- Low voltage terminal connections
- High pressure switch with manual external reset
- Heat pump hard start
- Cooling operation down to 60° F (15.6° C) standard on all units
- Models 9,000-12,000 Btuh only:
 - Large capacity suction accumulator
 - Solid-core filter drier

Thermostatically-controlled crankcase heater

- This feature energizes the crankcase heater only when needed, saving unnecessary power usage and increasing overall system efficiency.

System options

- Corrosion-resistant coil options (sea coast and harsh environment usage):
 - Copper fin/copper tube condenser coil
 - Coated aluminum fin/copper tube condenser coil
- Low Ambient controls for cooling operation down to 0° F (-18° C)
 - Optional field-installed kits, when specified, for cooling operation down to 0° F — kits include louvers/wind baffle, crankcase heater, and/or fan cycle switch, and installation instructions
- Models S1CG 9,000-12,000 Btuh only:
 - 115v (single-zone only — S1CG or S1HG)
 - Field-installed thermostatically-controlled crankcase heater for heat pump units (S1HG)

Installer-supplied items

- Power wiring.
- Low-voltage wiring (18 AWG minimum).
- Secure mounting pad or foundation.
- Refrigerant piping (if not purchased from EMI).
- High-voltage disconnect.
- Refrigerant for charging interconnect piping.

Table 2 Dimensional data, sound data and shipping weights

Model	Size Btu	Unit dimensions Inches (mm)			Sound level dBA	Shipping weight Lbs (kg)
		A	B	C		
S1CG/S1HG9	9,000	24 (610)	15 (381)	36 (914)	59	98 (44.5)
S1CG/S1HG2	12,000	24 (610)	15 (381)	36 (914)	59	98 (44.5)
S1CG/S1HG8	18,000	32 (813)	15 (381)	36 (914)	62	156 (70.9)
S1CG/S1HG4	24,000	32 (813)	15 (381)	40 (1016)	63	156 (70.9)
S1CG3	30,000	38 (965)	15 (381)	44 (1118)	68	210 (95.5)
S1CG6	36,000	38 (965)	15 (381)	48 (1219)	68	210 (95.5)

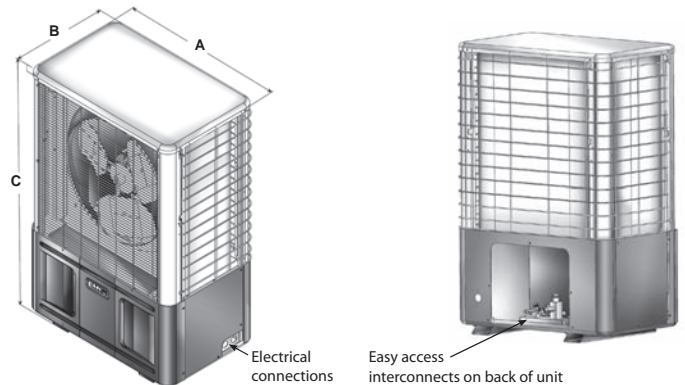
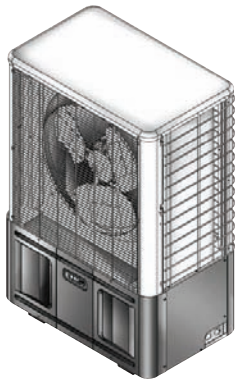

Table 3 Operational Ranges

Unit	Voltage	Accessories Part Numbers (Quantity) Required *** Order ALL Kits Listed Under the Operational Range ***			
		Operational Range			
		32° to 115° F (0 to 46° C)	0° to 115° F (-18 to 46° C)		
		Crankcase Heater Kit	Fan Cycle Switch Kit	Architectural Louver/Hail Guard/Wind Baffle Kit	
S1CG9000	115	550002072 (1)	550002072 (1)	550002074 (1)	550001577 (1)
S1CG2000	208/230	550002073 (1)	550002073 (1)	550002074 (1)	
S1CG8000	208/230	N/R	N/R	550002074 (1)	550001578 (1)
S1CG4000	208/230	N/R	N/R	550002074 (1)	550001602 (1)
S1CG3000	208/230	N/R	N/R	550002074 (1)	550001580 (1)
S1CG6000	208/230	N/R	N/R	550002074 (1)	550001581 (1)
S1HG9000	115	N/R	N/R	550002074 (1)	550001577 (1)
S1HG2000	208/230	N/R	N/R	550002074 (1)	550001577 (1)
S1HG8000	208/230	N/R	N/R	550002074 (1)	550001578 (1)
S1HG4000	208/230	N/R	N/R	550002074 (1)	550001602 (1)

Note: N/R - Not Required

WLCG/WLHG Air Handlers with S1CG/S1HG Condensers (continued)



S1CG/S1HG
Side Discharge



WLCG/WLHG



Table 4 Performance — cooling system with High Wall units

Condenser	Wall Units	Btuh (Kw)	SEER	SHR	EER	Ref.
S1CG9000	WLHG09	9,000 (2.6)	13.0	0.74	12.2	R-410A
S1CG2000	WLHG12	12,000 (3.5)	13.0	0.68	11.9	R-410A
S1CG8000	WLHG24	18,000 (5.3)	13.0	0.77	12.0	R-410A
S1CG4000	WLHG24	23,800 (7.0)	13.0	0.67	11.4	R-410A
S1CG3000	WLCG30	28,200 (8.3)	13.0	0.79	11.7	R-410A

Table 5 Performance — heat pump system with High Wall units

Condenser	Wall Units	Cooling Btuh (Kw)	Heating Btuh (Kw)	SEER	HSPF	SHR	EER	COP	Ref.
S1HG9000	WLHG09	9,000 (2.6)	8,600 (2.5)	13.0	7.7	0.72	12.8	3.3	R-410A
S1HG2000	WLHG12	12,000 (3.5)	10,600 (3.1)	13.0	7.7	0.69	11.8	3.3	R-410A
S1HG8000	WLHG24	18,000 (5.3)	16,400 (4.8)	13.0	7.7	0.76	11.9	3.5	R-410A
S1HG4000	WLHG24	23,800 (7.0)	20,600 (6.0)	13.0	7.7	0.71	11.9	3.5	R-410A

Table 6 WLCG/WLHG interconnecting line sizes

Capacity	Max. Equivalent Length	Max. Lift	Max. Trap Height	Liquid Line	Suction Line	Condensate Line
		"H"	"P"	O.D.	O.D.	I.D.
9,000	50' (15 m)	20' (6 m)	15' (5 m)	1/4"	1/2"	1/2"
12,000				1/4"	1/2"	1/2"
18,000	100' (30 m)	35' (11 m)	20' (6 m)	3/8"	5/8" *	1/2"
24,000				3/8"	3/4"	1/2"
30,000				3/8"	3/4"	1/2"

* Must bush down to 5/8" interconnect for 18K system

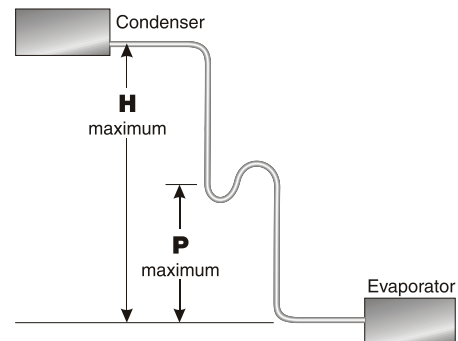

WLCG/WLHG

R-410A High-Efficiency Ductless Split System
High-Wall Air Handlers

EMI  *AmericaSeries*
Comfort Where It Counts.

Straight cool / Heat pump nominal capacities			
WLHG09	WLHG12	WLHG24	Units
9,000	12,000	18,000-23,800	Btuh
2.6	3.5	5.3-7.0	kW
Straight cooling only — nominal capacity			
WLCG30			Units
28,200			Btuh
8.3			kW

Engineering Submittal

Job Name:

Location:

Customer:

Project Engineer:

Project Architect:

General Contractor:

Submitted by:

For: Reference [] Approval []

Date:

ECR International LLC
5780 Success Drive
Rome, NY 13440
www.enviromaster.com



innovative living™
An ISO 9001-2000 Certified Company



NOTICE

EMI AmericaSeries air handlers and condensers are backed by EMI and ECR International and are tested, rated and certified in accordance with ARI Standard 210/240 and UL-1995. Due to ongoing product development, product designs and specifications may change without notice. Please contact the factory for more information.

Please fill in the boxes below to specify the air handler units

Selection 1

Quantity required:

Type [**WL** = wall-mounted air handler]

Operation [**C** = cooling—DX]
[**H** = heat pump (WL09–24 only)]

Revision [**G** = R-410A refrigerant]

Capacity [**09** = 9,000 Btuh]
[**12** = 12,000 Btuh]
[**24** = 18 / 24,000 Btuh]
[**30** = 30,000 Btuh (cooling only)]
[**36** = 36,000 Btuh (cooling only)]

Auxiliary heat:
[**0** = no auxiliary heat]
[**3** = 3 kw @ 208/230 VAC (09, 12, 24 only)]
[**5** = 5 kw @ 208/230 VAC (09, 12, 24 only)]

Voltage [**A** = 115 VAC (09–12 only)]
[**D** = 208/230 VAC]

EXAMPLES

W L C G 3 0 D 5

Cooling application | 36,000 Btuh capacity
| 208/230 VAC | 5 kw auxiliary heat

W L H G 2 4 D 5

Heat pump application | 18 / 24,000 Btuh capacity
| 208/230 VAC | 5 kw auxiliary heat

Please check the boxes below to specify optional field-installed accessories

<input type="checkbox"/>	Condensate Pump	<input type="checkbox"/>	Refrigerant line set, 10-feet
<input type="checkbox"/>	Remote thermostat for air handler	<input type="checkbox"/>	Refrigerant line set, 25-feet
<input type="checkbox"/>	Handheld IR remote controller	<input type="checkbox"/>	Refrigerant line set, 50-feet
<input type="checkbox"/>	Wind baffle / hail guard, architectural louver kit (required for cooling operation to 0°F (-18°C))		
<input type="checkbox"/>	Crankcase Heater (S1CG 9,000 - 12,000 Btuh only) required for cooling operating below 60°F (15°C)		
<input type="checkbox"/>	Hard Start Kit		
<input type="checkbox"/>	Fan Cycle Switch (required for cooling operation below 32°F (0°C))		

Please fill in the boxes below to specify the condenser unit

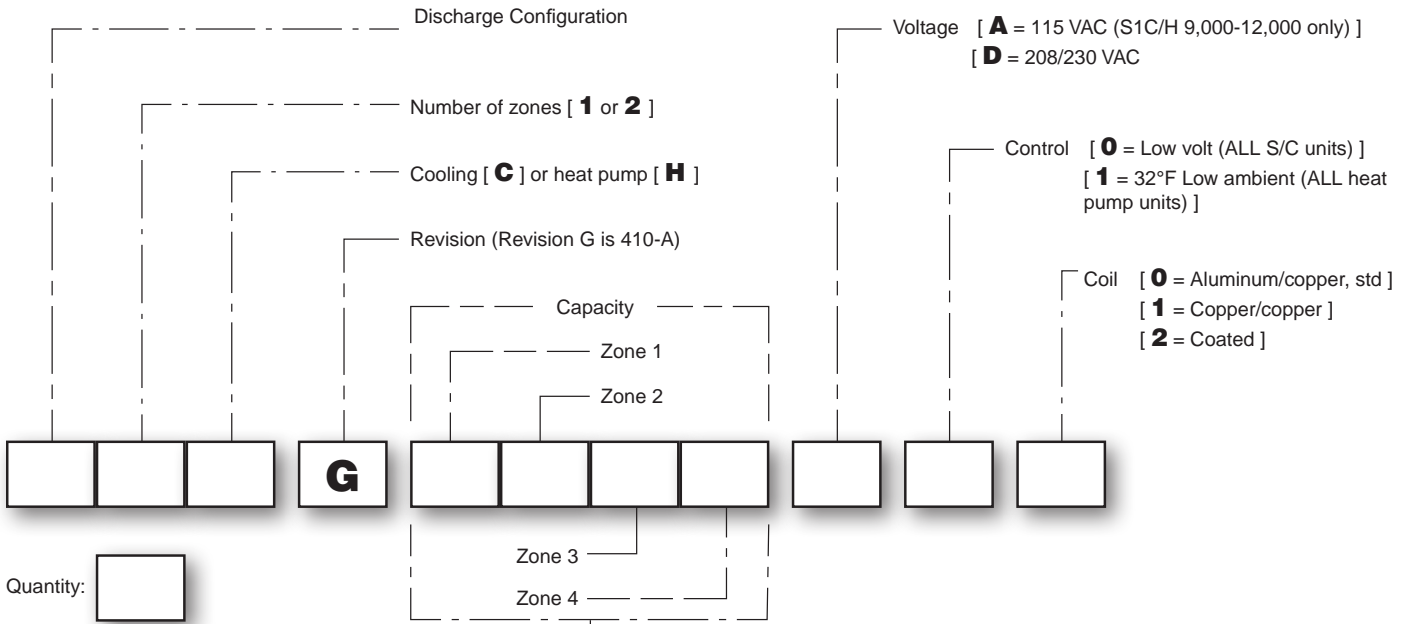

Capacity code	
Individual zone capacity	
Code	Capacity Btuh
0	Empty zone
9	9,000
2	12,000
8	18,000
4	24,000
3	30,000 *
6	36,000 *

* Straight cooling units ONLY

Available Units	
(S)	Description
Capacity codes	
9000	One zone 9,000 Btuh
2000	One zone 12,000 Btuh
8000	One zone 18,000 Btuh
4000	One zone 24,000 Btuh
3000 *	One zone 30,000 Btuh
6000 *	One zone 36,000 Btuh

* Available in straight cooling units ONLY

EXAMPLES

S 1 C G 8 0 0 0 D 0 1

Side discharge | one zone | cooling only | rev. G | 18,000 Btuh | 208/230 V | 32°F Low ambient control | copper fin, copper tube coil

T 2 H G 9 8 0 0 D 1 2

Top discharge | two zones | heat pump | rev. G | 9,000 / 18,000 Btuh | 208/230 V | 32°F Low ambient control | coated coil

S 2 H G 9 2 0 0 D 1 0

Side discharge | two zones | heat pump | rev. G | 9,000 / 12,000 Btuh | 208/230 V | standard low volt control | aluminum fin, copper tube coil

T 4 C G 9 9 2 2 D 0 2

Top discharge | four zones | cooling only | rev. G | 9,000 / 9,000 / 12,000 / 12,000 Btuh | 208/230 V | standard low volt control | coated coil

EMI's Product Line

Indoor Units

WLCG/WLHG
High Wall Air Handler



CACG/CAHG
Cassette Air Handler



UNCG/UNHG
Universal Floor or Ceiling Air Handler

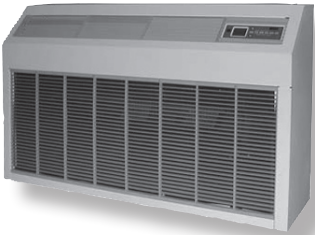

Outdoor Units

S2CG Dual Zone
Side Discharge

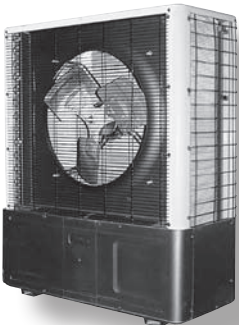

S1CG & S1HG
Single Zone
Side Discharge

T2CG, T3CG and
T4CG 2, 3 and 4 Zone
Top Discharge



ECR International LLC
5780 Success Drive
Rome, NY 13440
www.enviromaster.com



An ISO 9001-2000 Certified Company

Electrical Specifications

NOTICE

Due to ongoing product development, designs, specifications, and performance are subject to change without notice. Please consult the factory for further information.

Table 7 Electrical specifications — WLCG/WLHG

MODEL	VOLTS/HZ/PH	FAN RLA	HP	HEATER K.W.	AMPS	TOTAL AMPS	MIN VOLT	M.C.A.	HACR BRKR
WLHG 09-12	115/60/1	0.64	0.02	–	–	0.64	104	0.8	15
	208/230/60/1	0.34	0.02	–	–	0.34	197	0.4	15
	208/230/60/1	0.34	0.02	3	13.04	13.38	197	16.7	20
WLHG 24	208/230/60/1	0.56	0.07	–	–	0.56	197	0.7	15
	208/230/60/1	0.56	0.07	3	13.04	13.6	197	17	20
	208/230/60/1	0.56	0.07	5	21.74	22.3	197	27.9	30
WLCG 30	208/230/60/1	0.8	0.10	–	–	0.8	197	1	15
	208/230/60/1	0.8	0.10	5	21.74	22.54	197	28.2	30

Table 8 Electrical specifications — S1CG/S1HG

Model #	Volts/HZ/PH	Fan Motor		Compressor				Total amps	Min volt	M.C.A.	HACR BRKR
				Circuit 1		Circuit 2					
		AMPS	HP	RLA	LRA	RLA	LRA				
S1CG9000A S1HG9000A	115/60/1	1.4	0.125	7.5	47	N/A		8.9	104	10.8	15
S1CG2000A S1HG2000A	115/60/1	1.4	0.125	9.9	53	N/A		11.3	104	13.8	20
S1CG9000D S1HG9000D	208/230/60/1	0.8	0.125	3.9	20	N/A		4.7	197	5.7	15
S1CG2000D S1HG2000D	208/230/60/1	0.8	0.125	5.2	27	N/A		6.0	197	7.3	15
S1CG8000D S1HG8000D	208/230/60/1	0.8	0.125	5.9	43	N/A		6.7	197	8.2	15
S1CG4000D S1HG4000D	208/230/60/1	0.8	0.125	8.0	43	N/A		8.8	197	10.8	15
S1CG3000D	208/230/60/1	1.8	0.330	11.6	74	N/A		13.4	197	16.3	25
S1CG6000D	208/230/60/1	1.8	0.330	12.7	74	N/A		14.5	197	17.7	30

M.C.A. - minimum circuit amps

EMI's Product Line

Indoor Units

WLCG/WLHG
High Wall Air Handler



CACG/CAHG
Cassette Air Handler



UNCG/UNHG
Universal Floor or Ceiling Air Handler

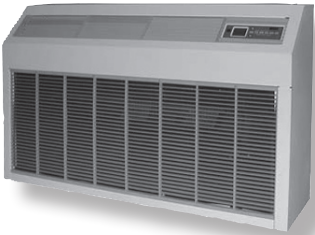

Outdoor Units

S2CG Dual Zone
Side Discharge

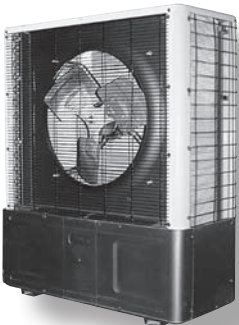

S1CG & S1HG
Single Zone
Side Discharge

T2CG, T3CG and
T4CG 2, 3 and 4 Zone
Top Discharge



ECR International LLC
5780 Success Drive
Rome, NY 13440
www.enviromaster.com
e-mail: info@enviromaster.com