



Comfort Where It Counts.

DCPC300 (CHP30-SCC30)

Rev. 1.1 [12/04]

JOB NAME: _____ LOCATION: _____
PURCHASER: _____
ENGINEER: _____
SUBMITTED TO: _____ FOR: REFERENCE [] APPROVAL [] CONSTRUCTION []
SUBMITTED BY: _____ DATE: _____
UNIT DESIGNATION: SCHEDULE #: _____ MODEL #: _____

EMI ENGINEERING SUBMITTAL

▲ CAPACITIES:

Cooling 28,500 Btu

Indoor Design Temp °F DB/WB

Cooling 80/67

Outdoor Design Temp °F DB/WB

Cooling 95/75

EER 10.0

SEER 10.2

▲ INDOOR UNIT:

Power Supply 208/230/1/60
Max. Fuse Size 15 Amps (w/o electric heat)
Min. Ampacity 1.4 Amps (w/o electric heat)
Max. Fuse Size 30 Amps (w/5kw electric heat)
Min. Ampacity 28.5 Amps (w/5kw electric heat)
Sound 56.0 dBA
Weight 135 Lbs

▲ OUTDOOR UNIT:

Power Supply 208/230/1/60
Max. Fuse Size 25 Amps
Min. Ampacity 15.8 Amps
Sound 67.2 dBA
Weight 155 Lbs

▲ REFRIGERANT PIPING:

Max. Lift 35 Ft
Max. Length 100 Ft
Liquid (OD) 3/8 In
Suction (OD) 7/8 In

▲ STANDARD FEATURES:

- Five-Year Compressor/One-Year Parts Warranty
- Anti-Short Cycle protection
- Fresh Air Knock-Outs
- Manual Reset High Pressure Switch
- Side Discharge/Low Profile Condenser
- Fan Purge

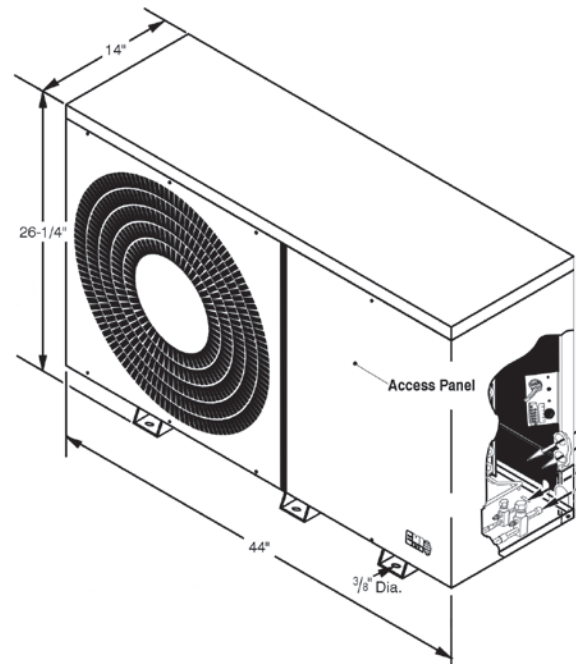
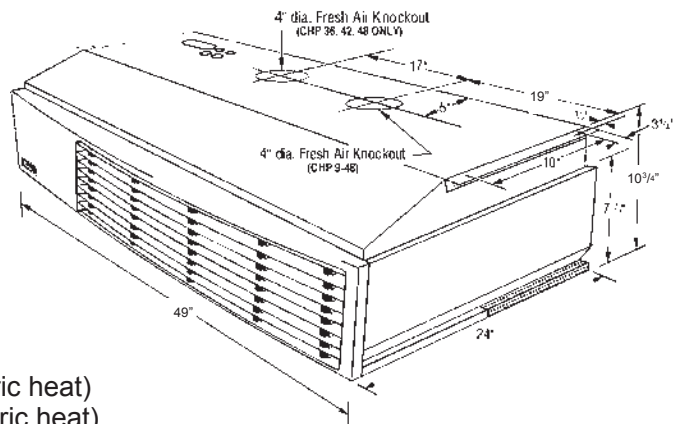

▲▼ PART ONE "GENERAL"

The Straight Cool air conditioning system shall be an EMI AmericaSeries split system. The system shall consist of a Ceiling mounted packaged evaporator section Model CHP30 and matching AmericaSeries outdoor unit Model SCC30. The units shall be made within North America. The units shall be listed by Intertek Testing Service (ITS) and bear the ETL label. All wiring shall be in accordance with the National Electrical Code (N.E.C.). The units shall be rated in accordance with ARI Standard 210/240 and bear the ARI label. The units shall be manufactured in a facility certified to ISO 9001, which is an international standard used to provide guidance in the development and implementation of an effective Quality Management System. The condensing unit shall contain an R-22 refrigerant charge for the evaporator section and condenser section. System SEER shall meet or exceed 1992 Federal Standards.

▲▼ PART TWO "WARRANTY"

The units shall have a manufacturer's warranty for a period of one (1) year from date of installation. The compressor shall have a warranty of five (5) years from date of installation. If, during this period, any part should fail to function properly due to defects in workmanship or material, it shall be replaced or repaired at the discretion of Enviromaster International LLC. This warranty does not include labor. Manufacturer shall have fifteen years experience in the U.S. market.

▲▼ PART THREE "PERFORMANCE"

Each indoor unit shall provide a total minimum cooling capacity of 28,500 Btuh with an SEER of 10.2 and EER of 10.0 at ARI standard conditions. The system net minimum total cooling capacity shall be 28,500 Btuh and the net minimum sensible cooling capacity shall be 18,800 Btuh with a circulating air rate of 800 CFM at 80° FDB/67° F (WB) entering the indoor coil and 95° F (DB) air entering the outdoor coil. The total power consumption of the combined system shall not exceed 2,850 Watts at these conditions.

▲▼ PART FOUR "INDOOR UNIT"

The indoor unit shall be factory assembled, wired and contain a low voltage transformer. The cabinet shall be fabricated of galvanized steel, finished in "off-white" with corrosion inhibiting polyester powder-coated paint. The evaporator fan shall be a forward curve centrifugal type, dynamically balanced and directly mounted to the motor shafts. The motor shall be PSC type with internal thermal overload protection. The supply louvers shall be dual adjustable for airflow direction. Return air shall be filtered by means of an easily removable electrostatic washable filter. The indoor unit shall have fresh air capability thru the top and back of the unit. The evaporator coil shall be of nonferrous construction with louvered fins bonded to rifled copper tubing. The tubing shall have inner grooves for high efficiency heat exchange. All tube joints shall be brazed with phosphor copper or silver alloy. The coil shall be pressure tested at the factory. A condensate pan and drain shall be provided under the coil. System refrigerant flow shall be controlled by means of an orifice piston in the indoor unit. The unit electrical power shall be 208/230 Volts, 1 phase, 60 Hertz. The system shall be capable of satisfactory operation within voltage limits of 208/230 +/- 10% Volts.

▲▼ PART FIVE "CONTROL SYSTEM"

The control system shall consist of 24V Wall Thermostat Control – anti-short cycle compressor protection; fan purge, fan remains on for 60 seconds after heat/cool call is dropped for improved efficiency; integral heating relay ensures that the fan operates whenever electric heat is energized; two stage heating capable when matched up with an EMI heat pump and an appropriate two stage thermostat. Wiring shall run from indoor unit to the 24V wall thermostat and to outdoor unit. **NO SPLICES**. When running low voltage wiring a double insulated 18 awg wire should be used. The control voltage between the indoor unit and the outdoor unit shall be 24 Volts A.C. The 24 Volts shall be generated from the indoor unit's 24 Volt 40VA transformer.

▲ PART SIX "OUTDOOR UNIT"

The outdoor unit shall be completely factory assembled, piped and wired. The cabinet shall be fabricated of G60 galvanized steel, finished in "off-white" with corrosion inhibiting polyester powder-coated paint. The unit shall be furnished with one (1) direct drive, propeller type fan arranged for horizontal discharge. The motor shall have inherent protection, be of the permanently lubricated type, and resiliently mounted for quiet operation. The fan shall be provided with a guard to prevent contact with moving parts. The compressor shall be of the high-performance reciprocating type with a thermal overload. The compressor shall be mounted so as to avoid the transmission of vibration. The refrigeration system shall be equipped with a high pressure switch and have the capability to operate with a maximum height difference of 35 feet and overall refrigerant tubing length of 100 feet between indoor and outdoor sections without the need for line size changes or additional oil. The condenser coil shall be of nonferrous construction with smooth louvered fins bonded to rifled copper tubing. The unit shall be controlled by a 24V wall thermostat and an electronic control board located in the indoor matching unit. The unit electrical power shall be 208/230 Volts, 1 phase, 60 Hertz. The system shall be capable of satisfactory operation within voltage limits of 208/230 Volts +/- 10%.

▲ PART SEVEN "OPTIONAL EQUIPMENT"

- **Infrared Control Package** – controls shall have the capability of sensing return air temperature and indoor coil temperature; large ¾" LCD backlit display; operational range adjustable between 55° F and 95° F in one-degree increments; anti-short cycle compressor protection; minimum compressor run time; fan purge, fan remains on for 60 seconds after heat/cool call is dropped for improved efficiency; freeze protection to prevent evaporator freeze ups; annunciation provides an audio feedback when the control settings are changed; universal control board allows the unit to operate with either a straight cool or heat pump condenser; two stage heating when optional electric heat and heat pump condenser are selected; fan operation of auto (cycling), high and low (constant), auto fan operation automatically selects fan speed according to heating or cooling demand; dry mode operates cooling and electric heat simultaneously to remove humidity, optional electric heat must be selected; test operation allows ease of testing after installation (all timers are eliminated); non-volatile back-up memory, control settings are maintained for an indefinite period during a power outage, when power is restored the equipment will resume operation after a three-minute compressor time delay; optional hand held infra-red controller.
- **Hand Held Inferred Remote Controller** – used to command the unit-mounted controls.
- **5KW Electric Heat** – shall be factory installed; automatic reset high temperature cutout and redundant high temperature fuse link.
- **Single-Stage hydronic heating coil** (one row type) w/sweat connections.
- **Internal Condensate Pump** – shall be field installed or factory installed and shall have 4 ft of head.
- **Trim Kit** – to cover mounting brackets when mounting unit flush to the ceiling.
- **Low Ambient Control** – shall consist of a fan cycle switch, field installed.
- **Hard Start** – shall be field installed.
- **Sea Coast Style Coated Coils** – shall be factory installed; coating shall protect against corrosion due to acids, solvents and salt.



5780 Success Drive, Rome, NY 13440
Phone: 1-800-228-9364
FAX: 1-800-232-9364
Email: emi@enviromaster.com