



Comfort Where It Counts.

TBH12-SCC09

Rev. 1.1 [1/05]

JOB NAME: _____ LOCATION: _____
 PURCHASER: _____
 ENGINEER: _____
 SUBMITTED TO: _____ FOR: REFERENCE [] APPROVAL [] CONSTRUCTION []
 SUBMITTED BY: _____ DATE: _____
 UNIT DESIGNATION: SCHEDULE #: _____ MODEL #: _____

EMI ENGINEERING SUBMITTAL

▲ CAPACITIES:

Cooling 9,500 Btu

Outdoor Design Temp °F DB/WB

Cooling 80/67

EER 10.0

SEER 10.5

▲ INDOOR UNIT:

Power Supply 208/230/1/60
 Max. Fuse Size 15 Amps (w/o electric heat)
 Min. Ampacity 0.5 Amps (w/o electric heat)
 Max. Fuse Size 20 Amps (w/3kw electric heat)
 Min. Ampacity 16.9 Amps (w/3kw electric heat)
 Sound 52.1 dBa
 Weight 160 Lbs

▲ OUTDOOR UNIT:

Power Supply 208/230/1/60
 Max. Fuse Size 15 Amps
 Min. Ampacity 6.1 Amps
 Sound 58.0 dBa
 Weight 90 Lbs

▲ REFRIGERANT PIPING:

Max. Lift 35 Ft
 Max. Length 100 Ft
 Liquid (OD) 1/4 In
 Suction (OD) 1/2 In

▲ STANDARD FEATURES:

- Five-Year Compressor/One-Year Parts Warranty
- Fresh Air knockouts
- Side Discharge/Low Profile Condenser
- "Duratec" Performance Package For Compressor Protection
 - Suction Accumulator
 - Filter Dryer
 - Loss Of Charge Switch

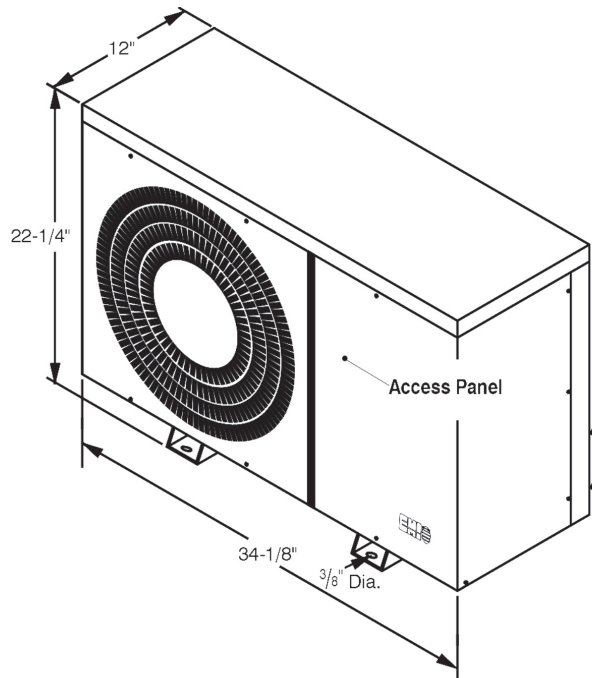
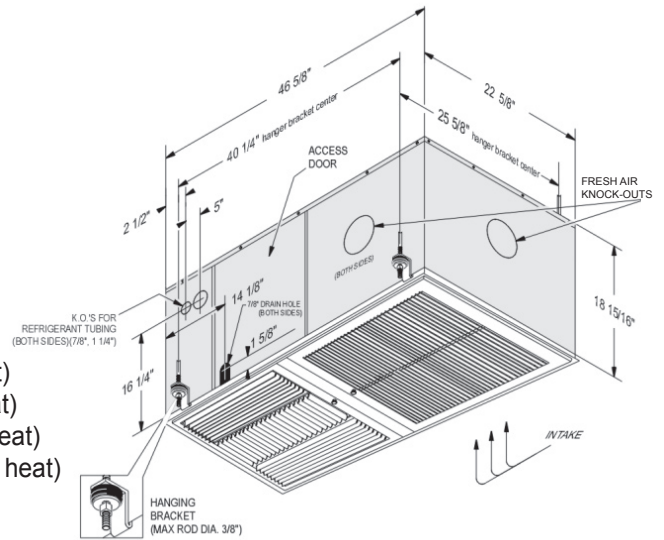

▲▼ PART ONE "GENERAL"

The Straight Cool air conditioning system shall be an EMI AmericaSeries split system. The system shall consist of a Ceiling Recessed packaged evaporator section Model TBH12 and matching AmericaSeries outdoor unit Model SCC09. The units shall be made within North America. The SCC shall be listed by Intertek Testing Service (ITS) and bear the ETL label. All wiring shall be in accordance with the National Electrical Code (N.E.C.). The units shall be rated in accordance with ARI Standard 210/240. The units shall be manufactured in a facility certified to ISO 9001, which is an international standard used to provide guidance in the development and implementation of an effective Quality Management System. The condensing unit shall contain an R-22 refrigerant charge for the evaporator section and condenser section. System SEER shall meet or exceed 1992 Federal Standards.

▲▼ PART TWO "WARRANTY"

The units shall have a manufacturer's warranty for a period of one (1) year from date of installation. The compressor shall have a warranty of five (5) years from date of installation. If, during this period, any part should fail to function properly due to defects in workmanship or material, it shall be replaced or repaired at the discretion of Enviromaster International LLC. This warranty does not include labor. Manufacturer shall have fifteen years experience in the U.S. market.

▲▼ PART THREE "PERFORMANCE"

Each indoor unit shall provide a total minimum cooling capacity of 9,500 Btuh with an SEER of 10.5 and EER of 10.0 at ARI standard conditions. The system net minimum total cooling capacity shall be 9,500 Btuh and the net minimum sensible cooling capacity shall be 7,050 Btuh with a circulating air rate of 350 CFM at 80° F (DB)/67° F (WB) entering the indoor coil and 95° F (DB) air entering the outdoor coil. The total power consumption of the combined system shall not exceed 950 Watts at these conditions.

▲▼ PART FOUR "INDOOR UNIT"

The indoor unit shall be factory assembled, wired and contain a low voltage transformer. The cabinet shall be fabricated of heavy gauge galvanized steel. The ceiling insert grill shall be a designer white, aluminum, architectural panel with fixed position intake louvers and fixed, three way discharge louvers to minimize recirculation. Return grill shall be hinged for quick access to filter. The evaporator fan shall be an assembly with direct drive, double width, double inlet, and forward curved centrifugal fan in draw through configuration. The motor shall be a PSC type, with overload protection and mounted on vibration isolators. Return air shall be filtered by means of an easily removable disposable standard 20" x 20" x 1" filter. The evaporator coil shall be of nonferrous construction with louvered fins bonded to rifled copper tubing. The tubing shall have inner grooves for high efficiency heat exchange. All tube joints shall be brazed with phosphor copper or silver alloy. The coil shall be pressure tested at the factory. A condensate pan and drain shall be provided under the coil. System refrigerant flow shall be controlled by means of an orifice piston in the indoor unit. The unit electrical power shall be 208/230 Volts, 1 phase, 60 Hertz. The system shall be capable of satisfactory operation within voltage limits of 208/230 +/- 10% Volts.

▲▼ PART FIVE "CONTROL SYSTEM"

The control system shall consist of 24V Wall Thermostat Control – single stage heating capable when optional electric heat selected. Wiring shall run from indoor unit to the 24V wall thermostat and to outdoor unit. **NO SPLICES**. When running low voltage wiring a double insulated, 18 gage cable is mandatory or use shielded cable. The control voltage between the indoor unit, outdoor unit and thermostat shall be 24 Volts A.C. The 24 Volts shall be generated from the indoor unit's 24 Volt 40VA transformer.

▲ **PART SIX “OUTDOOR UNIT”**

The outdoor unit shall be completely factory assembled, piped and wired. The cabinet shall be fabricated of G60 galvanized steel, finished in “off-white” with corrosion inhibiting polyester powder-coated paint. The unit shall be furnished with one (1) direct drive, propeller type fan arranged for horizontal discharge. The motor shall have inherent protection, be of the permanently lubricated type, and resiliently mounted for quiet operation. The fan shall be provided with a guard to prevent contact with moving parts. The compressor shall be of the high-performance rotary type with Duratec package which consists of an oversized accumulator, factory installed solid core filter and thermal overloads. The compressor shall be mounted so as to avoid the transmission of vibration. The refrigeration system shall be equipped with loss of charge switch, and have the capability to operate with a maximum height difference of 35 feet and overall refrigerant tubing length of 100 feet between indoor and outdoor sections without the need for line size changes or additional oil. The condenser coil shall be of nonferrous construction with louvered fins bonded to rifled copper tubing. The unit shall be controlled by a 24V wall thermostat. The unit electrical power shall be 208/230 Volts, 1 phase, 60 Hertz. The system shall be capable of satisfactory operation within voltage limits of 208/230 Volts +/- 10%.

▲ **PART SEVEN “OPTIONAL EQUIPMENT”**

- **3KW Electric Heat** – shall be factory installed; automatic reset high temperature cutout and redundant high temperature fuse link.
- **Internal Condensate Pump** – shall be field installed or factory installed and shall have 12 ft of head.
- **Low Ambient Control** – shall consist of a fan cycle switch and a crank case heater, field installed.
- **Hard Start** – shall be field installed.
- **Sea Coast Style Coated Coils** – shall be factory installed; coating shall protect against corrosion due to acids, solvents and salt.



5780 Success Drive, Rome, NY 13440
Phone: 1-800-228-9364
FAX: 1-800-232-9364
Email: emi@enviromaster.com