

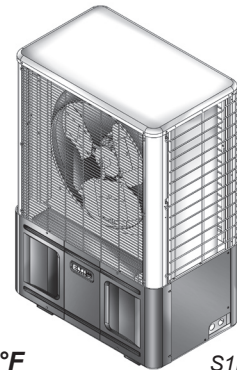

Comfort Where It Counts.

WLHA24-S1HA4
 Single-Zone Cooling / Heat Pump
 Rev. 1.0 [6/06]

JOB NAME: _____ LOCATION: _____
 PURCHASER: _____
 ENGINEER: _____
 SUBMITTED TO: _____ FOR: REFERENCE [] APPROVAL [] CONSTRUCTION []
 SUBMITTED BY: _____ DATE: _____
 UNIT DESIGNATION: SCHEDULE #: _____ MODEL #: _____



EMI ENGINEERING SUBMITTAL

▲ SYSTEM CAPACITIES:

Cooling 23,000 Btuh
 Heating (High) 20,600 Btuh
 Heating (Low) 11,400 Btuh

Indoor Design Temp °F

Cooling DB/WB 80/67
 Heating DB/WB 70/57

Outdoor Design Temp °F

Cooling DB/WB 95/75
 Heating (High) DB/WB 47/43
 Heating (Low) DB/WB 17/15

▲ STANDARD FEATURES:

Evaporator – High Wall Mounted:

- Universal unit mounted, infrared compatible control package, configurable to either unit mount or optional wall thermostat operation.
- Compatible with most standard wall mounted, 24V thermostats
- Motorized supply louver
- Integral field condensate pump connector
- Condensate pan over flow protection
- Anti-short cycle compressor protection
- Indoor coil freeze protection
- Dry mode for humidity control (*optional electric heat required*)
- Memory back up for auto re-start following power outage
- Fan purge

Condenser – Side Discharge / Vertically Arranged:

- R-22 refrigerant
- Suction Accumulator
- High pressure switch (*manual reset*)
- Start assist
- Coated wire coils and fan guards
- Five year compressor / one year parts warranty

WLHA24 ELECTRICAL SPECIFICATIONS							
Volts/ HZ/PH	Fan RLA	Heater K.W.	Amps	Total Amps	Min. Volt	M.C.A.	HACR BRKR
115/60/1	1.2	–	–	1.20	104	1.5	15
115/60/1	1.2	0.75	6.52	7.72	104	9.7	15
115/60/1	1.2	1.25	10.9	12.10	104	15.1	20
208/230/60/1	0.56	–	–	0.56	197	0.7	15
208/230/60/1	0.56	3	13.04	13.60	197	17.0	20
208/230/60/1	0.56	5	21.74	22.30	197	27.9	30

S1HA ELECTRICAL SPECIFICATIONS					
Model	Volts/HZ/PH	Total Amps	Min Volt	M.C.A.	HACR BRKR
S1H4D	208/230/60/1	8.8	197	10.8	15

HEAT PUMPS SYSTEM OPTIONS WITH WLHA						
Cooling Btuh	Heating Btuh	SEER	HSPF	SHR	EER	COP
23,000	20,600	13.0	7.7	.71	11.9	3.5



EMI ENGINEERING SUBMITTAL WLHA24-S1HA4

WLHA DIMENSIONS AND SPECIFICATIONS

NOTE: Due to ongoing development programs, design and specifications may change without notice.

WLHA PHYSICAL DIMENSIONS					
Model	"A" Depth	"B" Height	"C" Length	Clearance	
				"D" Mounting Bracket	"E" Tubing Access
WLHA24	9 7/8"	15 1/4"	48 1/2"	34"	36 1/2"

WLHA INTERCONNECTING LINE SIZES			
Capacity Btuh	Liquid O.D.	Suction O.D.	Condensate Drain Conn. I.D.
24	3/8"	3/4"	1/2"

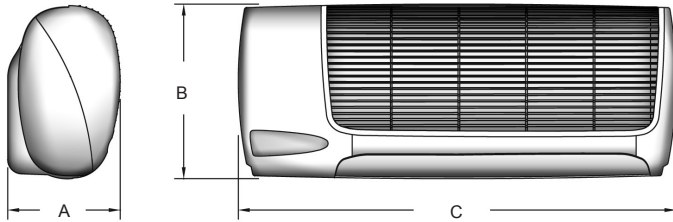

DISCHARGE AIR SPEED AND FLOW @ 230V					
Model	High CFM	Low CFM	Coil	FPM	Throw Ft.
18/24	750	675	Dry	1,225	25

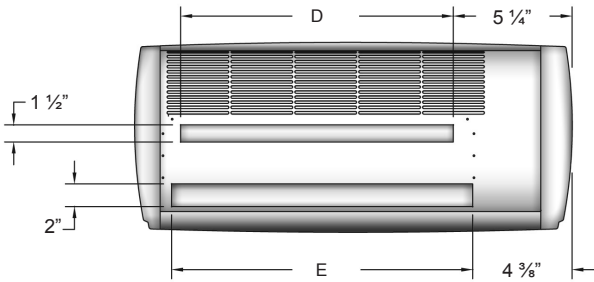

SOUND VALUES (230V High Speed Fan)	SHIPPING WEIGHT
dBA	Lbs.
56	66.20

S1HA SPECIFICATIONS AND DIMENSIONS

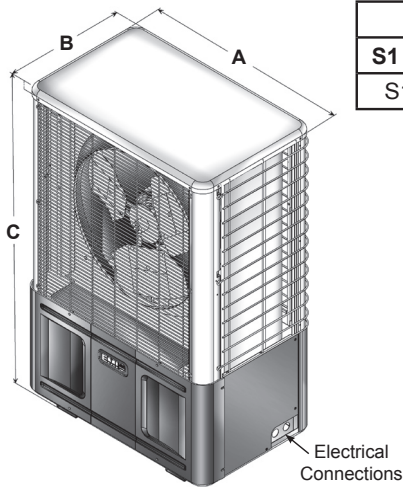

INTERCONNECTING TUBING SPECIFICATIONS					
S1 Model	Max. Length	Max. Lift	Liquid Line O.D.	Suction Line O.D.	Ref.
S1HA4	100'	35'	3/8"	3/4"	R-22

S1H SOUND DATA		Shipping Weight
Size Btuh	dBA	Lbs.
24,000	63	156

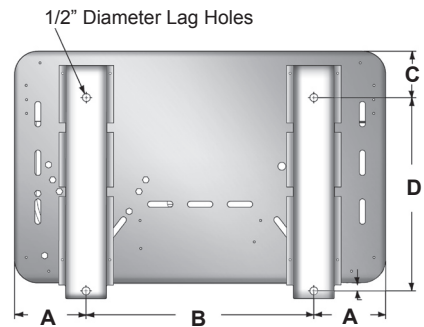

PHYSICAL DIMENSIONS			
Model Size	A	B	C
S1HA4	32"	15"	40"

MOUNTING DIMENSIONS				
Model Size	A	B	C	D
S1HA4	4 5/8"	22 11/16"	3"	12 7/16"

▲ PART ONE "GENERAL"

The heat pump air conditioning systems shall be an EMI America Series split system. The system shall consist of a high wall mounted packaged evaporator section Model WLHA24 and matching America Series outdoor unit Model S1HA4. The units shall be made within North America. The units shall be listed by Intertek Testing Service (ITS) and bear the ETL label. All wiring shall be in accordance with the National Electrical Code (N.E.C.). The units shall be rated in accordance with ARI Standard 210/240 and bear the ARI label. The units shall be manufactured in a facility certified to ISO 9001, which is an international standard used to provide guidance in the development and implementation of an effective Quality Management System. The condensing unit shall contain R-22 refrigerant charge for the evaporator section and condenser section. The system efficiency shall meet or exceed 2006 Federal Standards.

▲ PART TWO "WARRANTY"

The units shall have a manufacturer's warranty for a period of (1) year from date of installation. The compressor shall have a warranty of (5) years from date of installation. If, during this period, any part should fail to function properly due to defects in workmanship or material, it shall be replaced or repaired at the discretion of Enviromaster International LLC. This warranty does not include labor. Manufacturer shall have twenty years experience in the U.S. market.

▲ PART THREE "PERFORMANCE"

Each indoor unit shall provide at total minimum cooling capacity of 23,000 Btuh with a SEER of 13.0 and EER of 11.9 at ARI standard conditions. The system net minimum total cooling capacity shall be 23,000 Btuh and the net minimum sensible cooling capacity shall be 16,330 Btuh with a circulating air rate of 750 CFM at 80°F (DB)/67°F (WB) entering the indoor coil and 95°F (DB) air entering the outdoor coil. The total power consumption of the combined system shall not exceed 2,000 Watts at these conditions. The indoor evaporator shall have an air throw of 15 feet. The system shall provide a heating capacity of 20,600 Btuh with an HSPF of 7.7 and a COP of 3.5 at ARI standard conditions. The heating capacity at 70°F indoor and 17°F outdoor shall be 11,400 Btuh.

▲ PART FOUR "INDOOR UNIT"

The indoor unit shall be factory assembled, wired and contain a low Voltage transformer. The cabinet will be ABS plastic with a light gray finish and have a galvanized steel sub chassis. The evaporator fan shall be an assembly with line flow tangential fan direct driven by a single motor. The fan shall be statically and dynamically balanced and run on permanently lubricated bearings. A motorized louver shall be provided with the ability to change the airflow vertically. Horizontal-manually adjustable discharge louvers will be provided that can be placed in a fixed position. Return air shall be filtered by means of a washable, reusable mesh filter. The evaporator coil shall be of nonferrous construction with louvered fins bonded to rifled copper tubing. The tubing shall have inner grooves for high efficiency heat exchange. All tube joints shall be brazed with phoscopper or silver alloy. The coil shall be pressure tested at the factory. A condensate management system with over flow protection, condensate drain pan with anti-corrosion coating and drain shall be provided under the coil. System refrigerant flow shall be controlled by means of an orifice piston in the indoor unit. The unit electrical power shall be 208/230 or 115 Volts, 1 phase, 60 Hertz. The system shall be capable of satisfactory operation within the Voltage limits of 208/230 or 115 +/- 10%Volts.

▲ PART FIVE "CONTROL SYSTEM"

The control system shall consist of a universal unit mounted, infrared compatible control package, configurable to either unit mount or optional wall thermostat operation. Interconnected low voltage wiring shall run from indoor unit to outdoor unit direct, no splices. When running low voltage wiring a double insulated, 18 gage cable is mandatory or use shielded cable. The microprocessor shall be factory wired and located within the indoor unit. The control unit will have a large LCD backlit display and be configurable to either unit mount or remote wall thermostat operation. Unit mount-control operation allows the use of an optional IR hand held controller. The control shall have the capability of sensing return air temperature and indoor coil temperature. The operational range will have adjustable set points from 55°F to 90°F in one degree increments. The universal control can be used in cooling only, cooling with optional electric heat, heat pump or heat pump with optional second stage electric heat. Operation modes include, cool, heat, fan, auto change over and dry. Fan operation of auto (cycling), high and low (constant), auto fan operation automatically selects fan speed according to heating or cooling demand. Dry mode operates cooling and optional electric heat simultaneously to remove humidity (optional electric heat required). Test mode allows for ease of testing after installation (all timers are eliminated). Room air sampling (fan auto mode) cycles the fan on periodically to remove temperature stratification. Fan purge runs the indoor fan for 60 seconds after call is dropped for cool/heat, improving unit efficiency. Unit protection features include, anti short cycling compressor protection, minimum compressor run time,

freeze protection to prevent evaporator freeze, filter change indicator, condensate pan overflow switch, and integral condensate pump safety-switch connection. With this feature the control monitors the condensate pump safety switch and displays an error code if a fault occurs. The unit shall also provide non-volatile back up memory, where control settings are maintained for an indefinite period during a power outage. When power is restored the equipment will resume operation after a 3 minute compressor time delay. The control voltage shall be 24V AC generated from the indoor units transformer.

▲ **PART SIX "OUTDOOR UNIT"**

The outdoor unit shall be completely factory assembled, piped and wired. The cabinet shall be fabricated of 18 and 20 gauge aluminized steel, finished in "off-white" with corrosion inhibiting polyester powder-coated paint (2000 hour salt spray tested), and a black scratch and dent resistant injection molded front access panel. The unit shall be furnished with one (1) large diameter, direct drive, high efficiency, three blade, propeller type fan. The motor shall be PSC type with internal overload protection, and shall be the permanently lubricated type, and resiliently mounted for quiet operation. The fan shall be provided with a guard to prevent contact with moving parts. The compressor shall be a the high performance reciprocating or scroll type with thermal overloads. The compressor shall be mounted so as to avoid the transmission of vibration. The condenser shall have easy access hose connections at 45° from valve body. The refrigeration system shall be equipped with a high pressure switch (manual reset) and have the capability to operate with a maximum height difference of 35 feet and overall refrigerant tubing length of 100 feet between indoor and outdoor sections without the need for line size changes or additional oil. The condenser coil shall be U-shaped and protected by a wire coil guard. Construction is seamless copper tubing with enhanced aluminum fins. The tubes are mechanically expanded for secure bonding to fin shoulder. The unit shall be controlled by an electronic circuit board located in the indoor matching unit. The unit electrical power shall be 208/230 Volts, 1 phase, 60 Hertz. The system shall be capable of satisfactory operation within voltage limits of 208/230 Volts +/- 10%.

▲ **PART SEVEN "OPTIONAL EQUIPMENT"**

- **Hand held infrared remote controller**
- **24 Volt remote wall thermostat**
- **3KW or 5KW electric heat** with automatic reset high temperature cutout and redundant high temperature fuse link
- **Copper-copper condenser coils** – for protection against galvanic corrosion (*consult factory for coating options*)