



Comfort Where It Counts.

**CHP12 WITH S1CA2**  
Single-Zone Cooling Only

Rev. 1.1 [05/07]

JOB NAME: \_\_\_\_\_ LOCATION: \_\_\_\_\_  
 PURCHASER: \_\_\_\_\_  
 ENGINEER: \_\_\_\_\_  
 SUBMITTED TO: \_\_\_\_\_ FOR: REFERENCE [ ] APPROVAL [ ] CONSTRUCTION [ ]  
 SUBMITTED BY: \_\_\_\_\_ DATE: \_\_\_\_\_  
 UNIT DESIGNATION: SCHEDULE #: \_\_\_\_\_ MODEL #: \_\_\_\_\_



CHP12

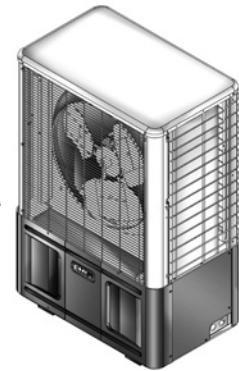

S1CA

▲ **CAPACITIES:**

Cooling ..... 11,800 Btuh

**Indoor Design Temp °F DB/WB**

Cooling ..... 80/67

**Outdoor Design Temp °F DB/WB**

Cooling ..... 95/75

▲ **STANDARD FEATURES:**

**Evaporator – Ceiling Suspended:**

- One-Year Parts Warranty
- Anti-Short Cycle protection
- Fresh Air knockouts
- Fan Purge

**Condenser – Side Discharge / Vertically Arranged:**

- R-22 refrigerant
- Duratec compressor protection
  - Suction Accumulator
  - Filter drier
  - Loss of charge switch
- Coated wire coils and fan guards
- Five year compressor / one year parts warranty

**CHP12D ELECTRICAL SPECIFICATIONS**

Volts/Hz/PH	Fan RLA	Heater K.W.	Amps	Total Amps	Min. Volt	M.C.A.	HACR BRKR
208/230/60/1	0.6	–	–	0.6	197	0.8	15
208/230/60/1	0.6	3	13.1	13.7	197	17.1	20

**S1CA ELECTRICAL SPECIFICATIONS**

Model	Volts/Hz/PH	Total Amps	Min Volt	M.C.A.	HACR BRKR
S1CA2	115/60/1	9.8	104	11.9	20
	208/230/60/1	5.3	197	6.4	15

**SYSTEM CAPACITIES CHP12 WITH S1CA2**

Cooling Btuh	SEER	SHR	EER
11,800	13.0	.74	11.7

**EMI ENGINEERING SUBMITTAL**



ARI Standard  
210/240 UAC

**EMI ENGINEERING SUBMITTAL CHP12 WITH S1CA2**

**CHP12 DIMENSIONS AND SPECIFICATIONS**

**NOTE:** Due to ongoing development programs, design and specifications may change without notice.

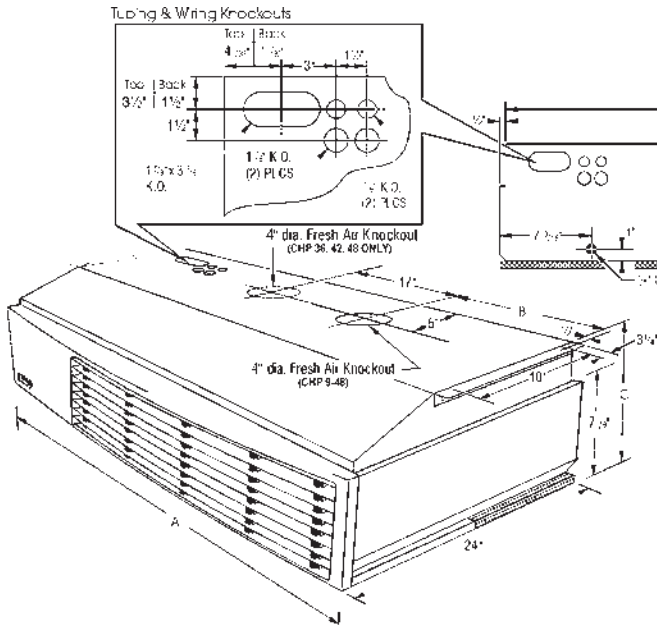

PHYSICAL DIMENSIONS					
Model	Width "A"	Width "B"	Width "C"	Width "D"	Width "E"
CHP12	42"	16 1/2"	10 3/4"	41"	5 1/2"

INTERCONNECTING LINE SIZES			
Model	Liquid O.D.	Suction O.D.	Condensate Drain Conn. I.D.
CHP12	1/4"	1/2"	1/2"

DISCHARGE AIR SPEED AND FLOW @ 230V						SOUND VALUES (230V High Speed Fan)	SHIPPING WEIGHT
Model	High CFM	Low CFM	Coil	FPM	Throw (Ft.)	dBA	Lbs.
CHP12	400	350*	Dry	900	15	46.3	115

\* Factory wired

**S1CA2 SPECIFICATIONS AND DIMENSIONS**

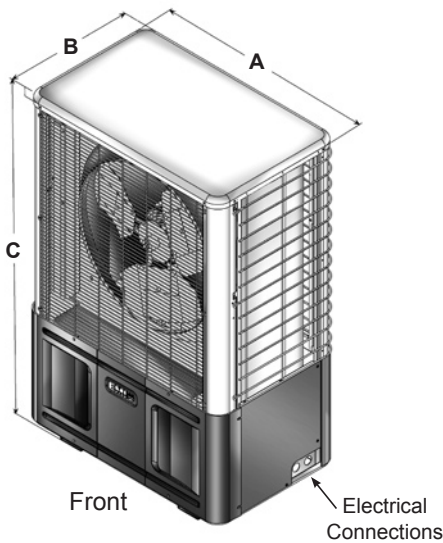

INTERCONNECTING TUBING SPECIFICATIONS					
Model	Max. Length	Max. Lift	Liquid Line O.D.	Suction Line O.D.	Ref.
S1CA2	100'	35'	1/4"	1/2"	R-22

SOUND DATA		Shipping Weight
Model	dBA	Lbs.
S1CA2	59	98

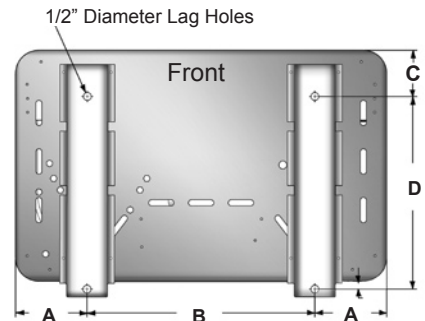

PHYSICAL DIMENSIONS			
Model	A	B	C
S1CA2	24"	15"	36"

MOUNTING DIMENSIONS				
Model	A	B	C	D
S1CA2	4 5/8"	14 11/16"	3"	12 7/16"

### ▲ **PART ONE “GENERAL”**

The straight cool air conditioning systems shall be an EMI America Series split system. The system shall consist of a ceiling suspended packaged evaporator section Model CHP12 and matching America Series outdoor unit Model S1CA2. The units shall be made within North America. The units shall be listed by Intertek Testing Service (ITS) and bear the ETLc label. All wiring shall be in accordance with the National Electrical Code (N.E.C.). The units shall be rated in accordance with ARI Standard 210/240 and bear the ARI label. The units shall be manufactured in a facility certified to ISO 9001, which is an international standard used to provide guidance in the development and implementation of an effective Quality Management System. The condensing unit shall contain R-22 refrigerant charge for the evaporator section and condenser section. The system efficiency shall meet or exceed 2006 Federal Standards.

### ▲ **PART TWO “WARRANTY”**

The units shall have a manufacturer’s warranty for a period of (1) year from date of installation. The compressor shall have a warranty of (5) years from date of installation. If, during this period, any part should fail to function properly due to defects in workmanship or material, it shall be replaced or repaired at the discretion of Enviromaster International LLC. This warranty does not include labor. Manufacturer shall have twenty years experience in the U.S. market.

### ▲ **PART THREE “PERFORMANCE”**

Each indoor unit shall provide a total minimum cooling capacity of 11,800 Btuh with an SEER of 13.0 and EER of 11.7 at ARI standard conditions. The system net minimum total cooling capacity shall be 11,800 Btuh and the net minimum sensible cooling capacity shall be 8,732 Btuh with a circulating air rate of 350 CFM at 80°F (DB) 67°F (WB) entering the indoor coil and 95°F (DB) air entering the outdoor coil. The total power consumption of the combined system shall not exceed 1,008 Watts at these conditions.

### ▲ **PART FOUR “INDOOR UNIT”**

The indoor unit shall be factory assembled, wired and contain a low voltage transformer. The cabinet shall be fabricated of G60 galvanealed steel, finished in “off-white” with corrosion inhibiting polyester powder-coated paint. The evaporator fan shall be a forward curve centrifugal type, dynamically balanced and directly mounted to the motor shafts. The motor shall be PSC type with internal thermal overload protection. The supply louvers shall be dual adjustable for airflow direction. Return air shall be filtered by means of an easily removable electrostatic washable filter. The indoor unit shall have fresh air capability thru the top and back of the unit. The evaporator coil shall be of nonferrous construction with louvered fins bonded to rifled copper tubing. The tubing shall have inner grooves for high efficiency heat exchange. All tube joints shall be brazed with phoscopper or silver alloy. The coil shall be pressure tested at the factory. A condensate pan and drain shall be provided under the coil. System refrigerant flow shall be controlled by means of an orifice piston in the indoor unit. The unit electrical power shall be 208/230 Volts, 1 phase, 60 Hertz. The system shall be capable of satisfactory operation within voltage limits of 208/230 +/- 10% Volts.

### ▲ **PART FIVE “CONTROL SYSTEM”**

The control system shall consist of 24V Wall Thermostat Control – anti-short cycle compressor protection; fan purge, fan remains on for 60 seconds after heat/cool call is dropped for improved efficiency; integral heating relay ensures that the fan operates whenever electric heat is energized. Wiring shall run from outdoor unit to the 24V wall thermostat and to indoor unit. ***NO SPLICES***. When running low voltage wiring a double insulated 18 AWG wire should be used. The control voltage between the indoor unit and the outdoor unit shall be 24 Volts A.C. The 24 Volts shall be generated from the indoor unit’s 24 Volt, 40 VA transformer.

### ▲ **PART SIX “OUTDOOR UNIT”**

The outdoor unit shall be completely factory assembled, piped and wired. The cabinet shall be fabricated of 18 and 20 gauge aluminized steel, finished in light gray and black corrosion inhibiting polyester powder-coated paint (2000 hour salt spray tested), and a black scratch and dent resistant injection molded front access panel. The unit shall be furnished with one (1) large diameter, direct drive, high efficiency, three blade, propeller type fan. The motor shall be PSC type with internal overload protection and shall be permanently lubricated and resiliently mounted for quiet operation. The fan shall be provided with a guard to prevent contact with moving parts. The compressor shall be of the high performance rotary type with Duratec package consisting of an oversized accumulator, factory installed solid

core filter drier and thermal overloads. The compressor shall be mounted as to avoid the transmission of vibration. The condenser shall have easy access hose connections at 45° from valve body. The refrigeration system shall be equipped with loss of charge switch, and have the capability to operate with a maximum height difference of 35 feet and overall refrigerant tubing length of 100 feet between indoor and outdoor sections without the need for line size changes of additional oil. The condenser coil shall be U-shaped and protected by a wire coil guard. Coil construction is seamless copper tubing with enhanced aluminum fins. The tubes are mechanically expanded for secure bonding to the fin. The unit shall be controlled by a 24V wall thermostat or an optional microprocessor control. The unit electrical power shall be 208/230V or 115V, 1 phase, 60 Hertz. The system shall be capable of operation within voltage limits of 208/230V or 115V +/- 10% is an option.

▲ **PART SEVEN "OPTIONAL EQUIPMENT"**

- **Infrared Control Package** – controls shall have the capability of sensing return air temperature and indoor coil temperature; large ¾" LCD backlit display; operational range adjustable between 55°F and 95°F in one-degree increments; anti-short cycle compressor protection; minimum compressor run time; fan purge, fan remains on for 60 seconds after heat/cool call is dropped for improved efficiency; freeze protection to prevent evaporator freeze ups; annunciation provides an audio feedback when the control settings are changed; universal control board allows the unit to operate either in straight cooling or heating when optional electric heat is selected; fan operation of auto (cycling), high and low (constant), auto fan operation automatically selects fan speed according to heating or cooling demand; dry mode operates cooling and electric heat simultaneously to remove humidity, optional electric heat must be selected; test operation allows ease of testing after installation (all timers are eliminated); non-volatile back-up memory, control settings are maintained for an indefinite period during a power outage, when power is restored the equipment will resume operation after a three-minute compressor time delay; optional hand held infra-red controller.
  
- **24 Volt Remote Wall Thermostat**
- **Hand Held Infrared Remote Controller** – used to command the optional unit-mounted controls
- **3Kw Electric Heat** – with automatic reset high temperature cutout and redundant high temperature fuse link
- **Single-Stage Hydronic Heating Coil** – (one row type) w/sweat connections.
- **Internal Condensate Pump** – shall be field installed and shall have 4 ft. of head
- **Trim Kit** – to cover mounting brackets when mounting unit flush to the ceiling
- **32°F Low Ambient Control Kit** – field installed for cooling operation when outdoor temperatures are from 60°F to 32°F, consisting of a fan cycle switch and a crank case heater
- **Wind Baffle Kit** – field installed, consists of a set of louvered panels for the condenser surface areas, which can be left on year round:
  - Wind Baffles in combination with the 32°F Low Ambient Kit will allow the unit to start and run at outside ambient temperatures down to 0°F
  - Wind Baffles also provide an attractive protective covering for the condenser coil surface as well as serving as a hail guard
- **Hard Start** – shall be field installed
- **Copper-Copper Condenser Coils** – for protection against galvanic corrosion
- **"Thermoguard"** – coil coating option