

INSTALLATION, OPERATION AND MAINTENANCE MANUAL

RC55 PACKAGED TERMINAL AIR CONDITIONER

Replacement For Remington Series

STRAIGHT COOL ONLY

Nominal Capacities:
9,000 - 12,000 Btuh

RETROAIRE

The Right Fit for Comfort



RC55



CC55

Enviromaster International LLC
5780 Success Dr.
Rome, NY 13440
Phone: 1-800-228-9364
Fax: 1-800-232-9364
Email: info@retroaire.com

An **ECR** International Brand 
An ISO 9001-2000 Certified Company

P/N# 240002990, Rev. 1.3 [02/05]

RC55 STRAIGHT COOL AIR CONDITIONER

INSTALLATION, OPERATION, AND MAINTENANCE GUIDE

P/N# 240002990, Rev. 1.3 [02/05]

Shipping Damage MUST be Reported to the Carrier IMMEDIATELY!!!

Examine the exterior. Remove cover and examine compressor and piping for signs of damage.

This manual is intended as an aid to qualified service personnel for proper installation, operation, and maintenance of the RetroAire RC55 Packaged Terminal Air Conditioner. Read these instructions thoroughly and carefully before attempting installation or operation. Failure to follow these instructions may result in improper installation, operation, service, or maintenance, possibly resulting in fire, electrical shock, property damage, personal injury, or death.

TO THE INSTALLER

- (1) Retain this manual and warranty for future reference.
- (2) Before leaving the premises, review this manual to be sure the unit has been installed correctly and run the unit for one complete cycle to make sure it functions properly.

To obtain technical service or warranty assistance during or after the installation of this unit, contact your local representative. Visit our website www.retroaire.com for a local representative listing. For further assistance call 1-800-228-9364.

When calling for assistance, please have the following information ready:

- Model Number _____
- Serial Number _____
- Date of installation _____

 **Recognize this symbol as an indication of important safety information** 

SAFETY INSTRUCTIONS

- ▲ Read all instructions before using the RetroAire RC55 PTAC. Install or locate this unit only in accordance with these instructions. Use this unit only for its intended use as described in this manual.
- ▲ Check the rating plate on the RetroAire RC55 PTAC before installation to make certain the voltage shown is the same as the electric supply to the unit.
- ▲ The RetroAire RC55 PTAC must be connected only to a properly grounded electrical supply. Do not fail to properly ground this unit.
- ▲ Turn off the electrical supply before servicing the RetroAire RC55 PTAC.
- ▲ Do not use the RetroAire RC55 PTAC if it has damaged wiring, is not working properly, or has been damaged or dropped.

[Save These Instructions]

DANGER

The RetroAire PTAC must:

- ▲ **Be connected to a properly grounded electrical supply with the proper voltage as stated on the rating plate.**
- ▲ **Have proper over current protection (i.e. time-delay fuse/HACR-Breaker) as listed on the Rating Plate.**

Failure to follow these instructions can result in a fire, explosion, or electrical shock causing property damage, personal injury, or death.

TABLE OF CONTENTS

To the Installer and Safety Instructions	2-3
Warnings and Installer Responsibilities	3
Controls and Components	4
Product Description, Capacities, Air System	4
Heat-exchanger, Refrigeration, Electrical Wiring .	4
Installation Instructions	5-6
Final Inspection and Start-Up	6
Sequence of Operation	7-8
Cleaning and Maintenance	9
Troubleshooting	9
Specifications and Dimensions	10
Warranty	11

INSTALLER RESPONSIBILITIES

This manual has been prepared to acquaint you with the installation, operation and maintenance of this RetroAire RC55 PTAC and to provide important safety information in these areas.

We urge you to read all of the instructions thoroughly before attempting the installation or operation of this unit. This manual should be kept for future reference.

The manufacturer of this unit will not be liable for any damages caused by failure to comply with the installation and operating instructions outlined in this manual.

A rating plate identifying this RetroAire RC55 PTAC can be found on the unit. When referring to your unit, always have the information listed on the rating plate readily available.

MODIFICATION AND TAMPERING



Tampering with the RetroAire RC55 PTAC is dangerous and may result in serious injury or death. Tampering voids all warranties. Do not attempt to modify or change this unit in any way.

IMPORTANT SAFETY FEATURE

Power Cord With Integral Safety Protection

All PTACs rated 250V or less that are cord connected to the power supply are equipped, with a power cord with integral safety protection as standard. Providing personal shock protection as well as arcing and fire prevention. The device is designed to sense any damage in the line cord and disconnect power before a fire can occur. Tested in accordance with Underwriters Laboratories, the cord set also offers a unique "passive" operation, meaning the unit does not require resetting if main power is interrupted.

WARNING - A DAMAGED POWER SUPPLY CORD MUST BE REPLACED WITH A NEW CORD FROM THE MANUFACTURER, AND NOT REPAIRED.

Each power cord should be checked before every use. Follow the instructions in the order listed on the device.

WARNING - DO NOT USE THE PRODUCT IF THE UNIT FAILS THE TEST.



Completely read all instructions prior to assembling, installing, operating, or repairing this product. **Inspect all parts for damage prior to installation and start-up. The RetroAire RC55 PTAC must be installed ONLY by qualified installation personnel.**

PRODUCT DESCRIPTION

The RetroAire RC55 replacement chassis is a conditioner designed to allow owners of Remington units to upgrade the performance of their room conditioning and achieve current efficiency standards.

With energy efficiency ratings as high as 9.0, replacement of worn out and inefficient units becomes a very attractive option.

The RetroAire RC55 cooling chassis with the evaporator blower section can be mated with existing electric or hydronic heat sections, or replacement heat sections may be ordered as options. The control box is standard with the chassis.

Whisper quiet operation improves room ambiance and a washable, permanent filter makes service a snap. The 20 gauge, galvanized steel construction of the chassis ensures long service life.

All RetroAire products are backed by Enviromaster International LLC and are tested and rated in accordance with ARI standards 310, 380, and UL484.

STANDARD CONTROLS & COMPONENTS (Factory Installed or Supplied)

- Unit mounted operating controls: Rotary thermostat, fan speed control, heat/cool switch when applicable
- Baffle kit
- Weather strip insulation
- Foam strips for supply air duct
- Normally/open normally/closed motor valve-switch, (hydronic heat only)

FACTORY OPTIONS & ACCESSORIES

- Manual fresh air damper
- Fan cycle switch
- Remote thermostat
- 3 or 4kw electric heat
- 1 or 2 row hydronic heat (field Installed)
- 2 or 3-way water valve (field Installed)
- Sea coast coated coils and drain pans

PREPARATION FOR INSTALLATION

1. Remove the old unit from the wall sleeve and dispose of properly.
2. Inspect the wall sleeve for rust or damage and clean or repair as necessary.
3. Remove and repair old weather seals and note locations for new seals.
4. Make sure the wall sleeve is pitched to the outside by 1/2" and drain holes are open.
5. Make sure one 2-3/8" x 10-7/16" baffle is installed on the condenser coil.

Note: It is very important to choose the correct baffles for the specific job to obtain proper air circulation.

6. Position 1" x 1" foam strip air seals in between the wall sleeve and cooling chassis to prevent outside air from entering the room around the chassis from the sides and top of the cabinet.

ELECTRICAL WIRING

1. Inspect existing wiring for any deficiencies (ex.- wires cut or frayed).
2. All electrical wiring must be run according to NEC and local codes. Check the unit rating plate for circuit ampacity and breaker or fuse size. Use only HACR type breakers. Select the proper wire for the ampacity rating.
3. If plug and receptacle are used, check for proper fit.

INSTALLATION INSTRUCTIONS

RC55 INSTALLATION KIT

- | | |
|---|---|
| <ul style="list-style-type: none"> • 1 Installation Manual • 1 Condenser Baffle • 2 #8x3/8 Screws • 2 Thermostat Bulb Clips | <ul style="list-style-type: none"> • 2 Thermostat Bulb Clips Grommets • 1/2" x 1/2" Open-cell Foam Tape • 1" x 1" Open-cell Foam Tape • 1/2" x 1/2" Closed-cell Foam Tape |
|---|---|

1. When installing the cooling chassis, make sure the side rails are set in position on the cooling chassis and wall sleeve sides. Slide the cooling chassis into place and make sure the condenser baffle ensures proper air circulation.

2. Place the 1/2" X 1/2" open cell foam tape on top of the unit where the evaporator housing attaches to the plenum. Make sure the side of the foam tape is flush with the front edge of the evaporator housing. The foam tape should cover the entire area. (Figure 1)

Figure 1
Polyfoam Location

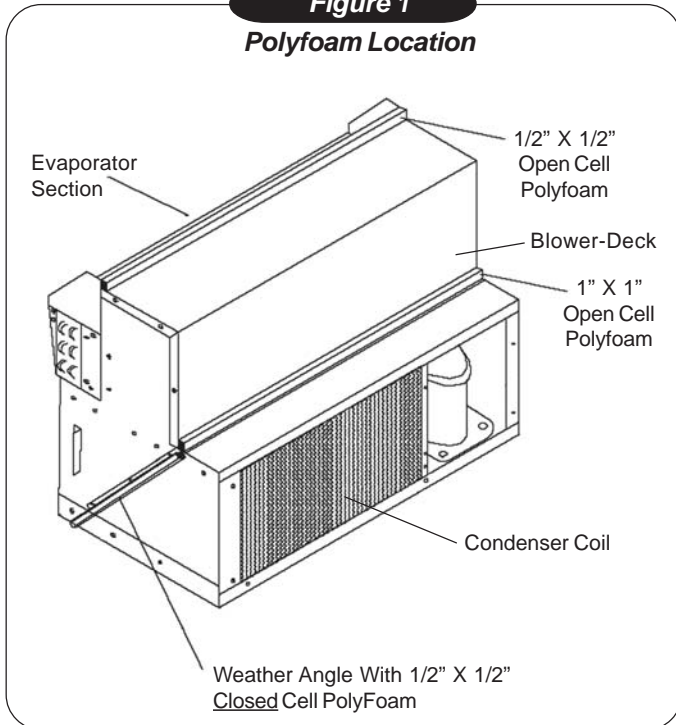

3. The 1" X 1" open cell foam tape should be attached at the junction of the condenser and the blower-deck. (Figure 1)

4. Attach the 1/2" X 1/2" closed cell foam tape to the bottom of the weather angles on both sides of unit. (Figure 1)

IMPORTANT: The correct condenser air baffles must be installed or performances may be impaired and/or the warranty will be voided.

5. Remove baffle from the kit bag supplied with unit. The condenser baffle must be secured tightly to the condenser coil and the baffle need to come in contact with the outdoor louver. To install the baffle point it toward the center of the condenser and fasten using the existing holes and screws provided. (Figure 2)

Figure 2

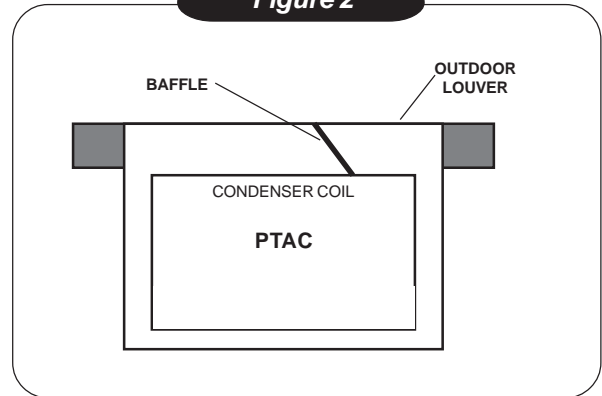

6. To Mount the control box: (Figure 3)

- Place control box in the space provided in the cabinet and position the deco over the opening in the cabinet.
- Tighten the screws through the deco into the control box, securing all to the cabinet.

7. Wire the control box by selecting the 3-position Molex plug and plugging it into the three-prong Molex on the control box. Then plug the four-prong plug into the four prong wire connection on the cooling chassis and be sure to check Molex wires for the correct color code (Ex. – red to red, white to white, etc.).

Figure 3
Control Box

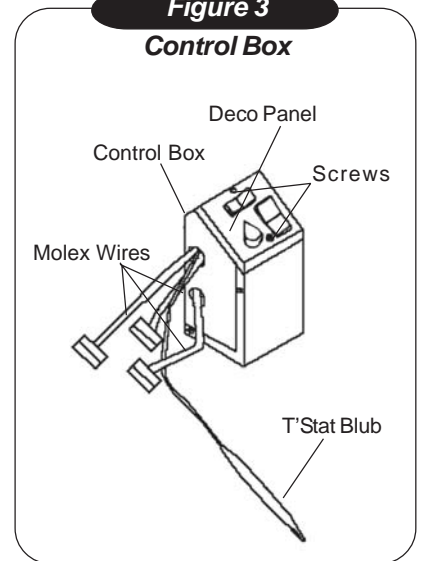

Note: Make sure the Molex plugs are connected correctly to ensure proper operation of the unit.

INSTALLATION INSTRUCTIONS *Continued*

8. Plug line cords into receptacles.

Note: Check rating plate voltage and amperage/fuse size for proper supply.

9. To install thermostat bulb to coil.

- Remove air filter from coil.
- Take the thermostat bulb clips and grommets out of the baffle kit bag.
- Slide grommets into clips.

- Install on the middle of the evaporator coil by pressing the round part of the clips through the coil fins.
- Once this is done, position thermostat bulb into clips.
- Replace air filter.

10. Turn power on.

11. Check for proper operation (cooling, fresh air, and heating (if supplied)).

FINAL INSPECTION AND STARTUP



CAUTION

When the unit is first powered up, high humidity conditions can cause condensation to form on the discharge grill. Keep doors and windows closed to reduce humidity and condensation will evaporate.

1. Make sure the chassis is level. Check by pouring water into the drain pan and making certain it flows through the drain hoses to the condenser side of the unit.

2. Plug or hard wire line voltage to unit.

IMPORTANT: Follow the information provided on the rating plate for voltage and amperage/fuse size for proper supply.

3. Attach the front panel to the existing cabinet enclosure.

4. Turn the power on.

5. Check for proper operation (i.e., cooling, optional fresh air, and heating if supplied).

6. Check to be sure nothing will interfere with the room discharge air or the return air to the units (i.e., curtains or drapes that obstruct the air flow or plush carpeting that can obstruct the return air (see below)). Items like these can cause serious damage to the chassis and can void the warranty.

The position of curtains or drapes over supply air grille may cause air to recirculate without cooling the room. The unit will short cycle and may cause premature compressor failure.

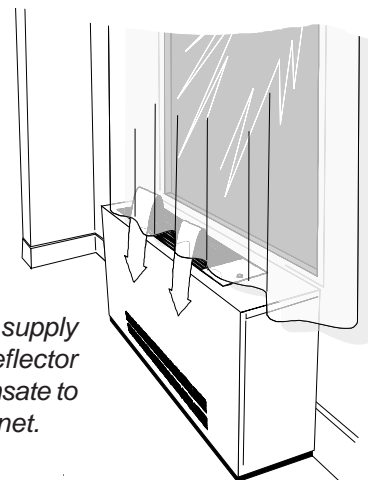

NOTE: Any obstruction of supply air including the use of deflector baffles, may cause condensate to form on the louver or cabinet.

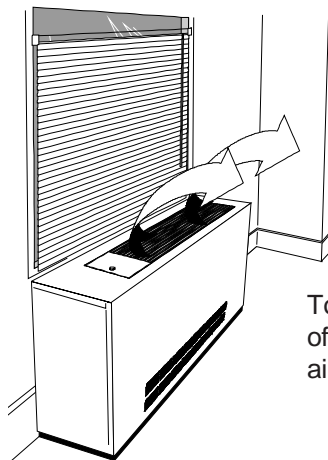

To ensure optimum performance of your PTAC, avoid restricting the air flow.

SEQUENCE OF OPERATION

UNIT MOUNTED AND REMOTE THERMOSTAT CONTROLS: RetroAire units can be equipped with unit mounted or remote controlled thermostats. Turning the unit mounted thermostat knob to the far left will produce the warmest room temperature while turning it all the way to the right will produce the coolest. These settings can be adjusted for personal comfort.



CAUTION

Avoid rotating the thermostat knob back and forth from heating to cooling. This causes the compressor to cycle on and off rapidly and **WILL** cause damage to the compressor. Allow the compressor to remain off for at least three minutes prior to restarting the unit.

COOLING CYCLE

1. Place system switch in the “COOL” position.
2. Rotate thermostat knob (*Figure A*) clockwise until the compressor fans start running and cold air begins to flow from the unit. For a colder room temperature, continue turning the thermostat knob clockwise and let the unit continue operating to cool the room and remove humidity. If a warmer room temperature is desired, rotate the thermostat knob counter-clockwise until the compressor cycles off.

IMPORTANT: The room temperature must be above 65° F for the compressor to operate.

3. Place system switch in the “OFF” position. All operation should stop.

HEATING CYCLE - ELECTRIC

1. Place system switch in the “HEAT” position.
2. Rotate thermostat knob counter-clockwise until the indoor fans start running and the electric coil starts emitting heat. The condenser fans do not run during the heating cycle unless the chassis is a heat pump. After the unit starts running and the area gets warmer, turn the thermostat knob clockwise until a slight click is heard and the electric heater turns off. If a warmer room temperature is desired, continue turning the knob counter-clockwise and let the unit continue operating. If a cooler room temperature is desired, rotate the thermostat knob clockwise until the electric heater cycles off.

Figure A

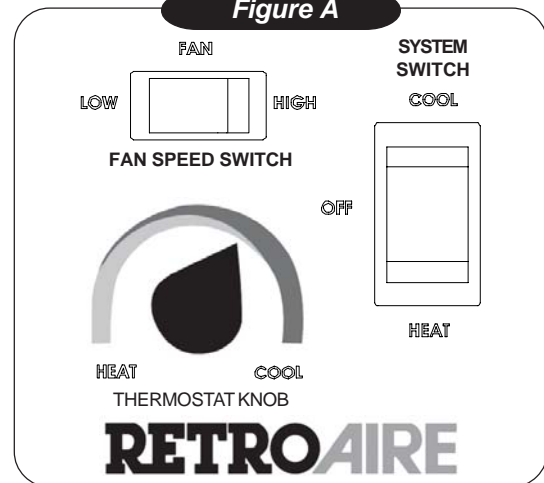

IMPORTANT: Room temperature must be below 85° F to energize the heater.

3. Place system switch in the “OFF” position. All operation should stop.

HYDRONIC COIL: The coil with the old unit can be located in the subbase, under the chassis in a special attachment, or above the chassis in a special attachment. It is necessary to know where the coil is to be located and the physical size of the coil so the right coil can be supplied if ordered for replacement. The coil is shipped loose for field installation. It should be installed in the same manner as the coil it is replacing. When the hydronic coil is not replaced, installation of the chassis should follow the instructions in this manual.

HEATING CYCLE - HYDRONIC: All straight cool Dual Motor PTACs are equipped with a field supplied hydronic heat option. The unit is provided with a two-position molex plug for motor valve connection. To wire this option, take the molex plug connector with (2) yellow wires from the kit and plug it into the molex on the unit. Then wire the opposite end of the molex to the motorized valve in the hydronic circuit.

IMPORTANT: Make sure the motor valve is rated for the correct voltage. Most RetroAire units with unit mount controls will power a normally closed valve that is the same voltage as the unit (ex: a unit rated 208/230V will power a 208/230V normally closed valve). Be sure to check the wiring diagram (located on the unit) and voltage application for the specific unit. Other valve configurations and voltage options are available. Consult Technical Service if the unit voltage does not match your valve application.

- A. Place system switch in the "HEAT" position.
- B. Turn thermostat knob counter-clockwise. Motorized valve should open and allow hot water to run through the coil. the indoor fans will run, blowing air through the hydronic coil.
- C. Check room comfort level as outlined under "Heating Cycle - Electric."

MOTORIZED FRESH AIR DAMPER (OPTIONAL): The optional motorized fresh air damper allows the operator to move fresh air into the space to be conditioned. This is done by placing the damper door switch in the "YES" position, opening the damper door and allowing fresh air to be moved into the space. To stop the flow of fresh air, simply place the switch in the "NO" position.

CHANGEOVER T-STATS (HEAT PUMP ONLY): On units with a changeover thermostat, the compressor can run to an outdoor temperature of 40° F and then shut off. Electric heat will then energize and assume the heating demand until the temperature of the outdoor air rises to approximately 50° F.

FAN CYCLE SWITCH: This option allows the operator of the Dual Motor PTAC to have the evaporator fan cycle or run continuously. With the switch in the cycling position the evaporator fan will only run when the unit is calling for heat or cooling. When the switch is in the "CONSTANT" position, the evaporator fan will run continuously unless the unit is physically turned off.

CONDENSATE REMOVAL: The Dual Motor PTAC has a drain connection at each end of the condensate drain pan. This allows the condensate to drain through the bulkhead to the area near the condenser fan. The condenser fan has a slinger ring that picks up the condensate and slings it on the hot condenser coil where it evaporates. On heat pump models condensate can form on the outdoor coil during the heat pump cycle. A temperature sensitive valve in the base pan will allow condensate to flow to an internal piping system or external drain kit (supplied by others).

AQUASTAT CONNECTION (OPTIONAL): All straight cool Dual Motor PTACs are supplied with a standard high volt aquastat connection. The connection is located on the bottom or side with a black jumper wire installed in molex. To wire option take jumper wire and cut in half. Then connect 2 field supplied wires to the cut ends of jumper and wire to aquastat (see wiring diagram for more information). If option is not being used simply leave jumper wire connected to unit.

CLEANING AND MAINTENANCE

⚠ DANGER ⚠

Before servicing the RetroAire Dual Motor PTAC, be sure to turn off electrical power to the unit. Failure to do so can result in a fire, explosion or electrical shock causing property damage, personal injury or death.

⚠ WARNING ⚠

It is illegal to discharge refrigerant into the atmosphere. Use proper reclaiming methods and equipment when servicing a RetroAire Dual Motor PTAC.

CLEANING THE INTERIOR OF THE UNIT

1. Disconnect power from unit.
2. Remove access panels and do a visual inspection of the unit, making sure to check for obvious problems such as damaged coils or evidence of extended wear on any moving part.
3. Check for unusual odors, oil leaks, or stains on or around the coil and refrigerant lines. The presence of oil here may indicate a potentially serious problem such as a refrigerant leak.
4. Inspect all electrical connections. Look for frayed wires and poor connections. Terminal ends that are loose will eventually fail, causing a loss of performance or worse.
5. Check fan motors and blower assemblies. Some units may require a drop of light oil to motors and/or bearing assemblies (look for oil cups). Check set-screws and motor mounting hardware, making sure they are tight.
6. Brush and/or vacuum the centrifugal fan blades and blower cage assemblies. These parts must be clean to operate efficiently.
7. Inspect and clean the indoor and outdoor coils, using a fin comb, if necessary, to straighten any damaged fins. these coils must be clean for proper operation.

IMPORTANT: Do not use a solvent-based cleaner on the indoor or outdoor coils. Some solvents can produce a noxious odor when starting the fan or electric heat.

8. Inspect and clean the drain pan and drainline (if any). Use of an anti-fungicide tablet is recommended to keep the condensate system free from bacterial contaminants.

9. Check weep holes along the rear flange of the base pan, making sure they are open.
10. Check the pitch of the unit. Over time the building and equipment may settle, causing a shift in the direction of the condensate flows. Ideally the unit should pitch a minimum of 5° (at least ½") to the outside to allow for proper drainage.
11. Replace panels and reconnect electrical power.
12. Test unit operation.

CLEANING THE EXTERIOR

1. Clean the air filter at least once a month by removing it from the unit and washing or vacuuming any dust from its surface. Allowing dust to collect on the filter will cause the PTAC to lose efficiency and eventually malfunction.
2. When cleaning the filter, be sure to vacuum any dust from the return air grille surface as well.
3. Clean exterior of the cabinet as desired with a mild soap or household cleaner.

IMPORTANT: If a new air filter is needed for your RetroAire Dual Motor PTAC, consult factory for availability and/or proper sizing.

TROUBLESHOOTING

- If the compressor will not start, check to see if the thermostat is satisfied. If the thermostat is not satisfied, check for proper wiring and make sure that relays are not damaged.
- If there is no electric heat, see if heater contacts pull in. Possible problems could be the heat relay, limit switch, or fuse link.
- If you are unable to find any of these problems, contact the factory for further information.

DIMENSIONS AND SPECIFICATIONS

Note: Due to ongoing development programs, design and specifications may change without notice.

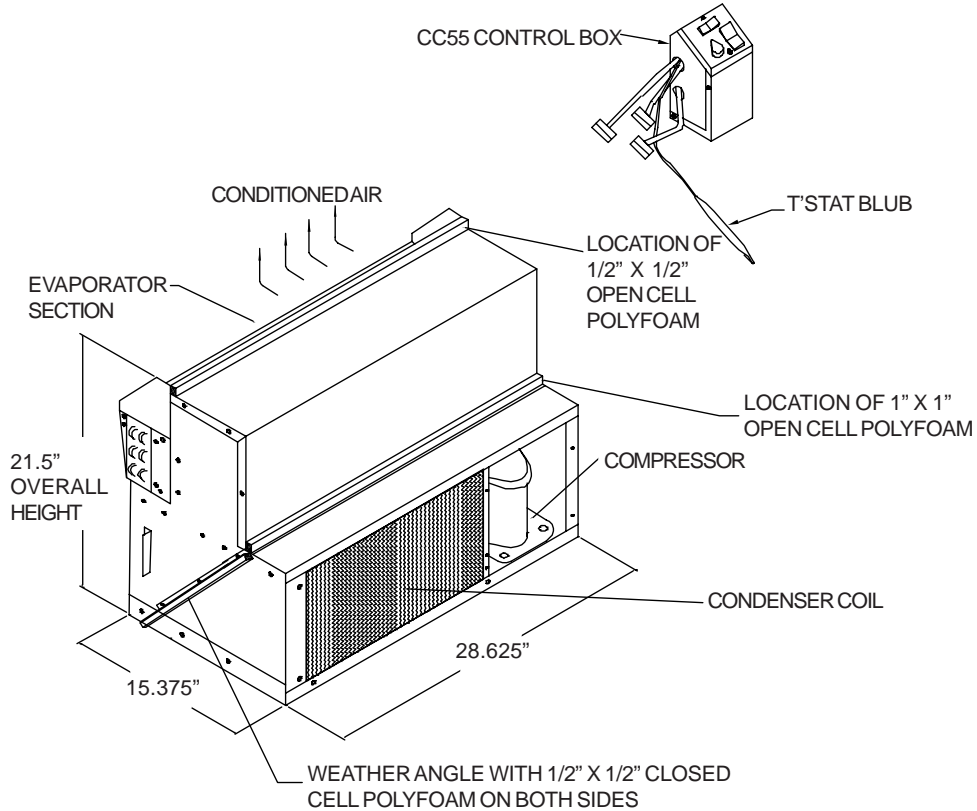

ELECTRICAL SPECIFICATIONS

UNIT SIZE	VOLTS/HZ/PHASE	COND FAN		COMPRESSOR		EVAP FAN		TOTAL AMPS	MIN VOLT	MCA	FUSE	LINE CORD
		AMPS	HP	RLA	LRA	AMPS	HP					
9	208/230/60/1	1.1	0.15	4.8	31	0.6	0.08	6.5	197	7.7	15	6-15P
12	208/230/60/1	1.1	0.15	5.8	31	0.6	0.08	7.5	197	9	15	6-15P

OPTIONAL ELECTRIC HEAT SPECIFICATIONS

HEATER NO.	VOLTAGE	WATTS	BTUH	AMPS	TOTAL	MCA	FUSE	LINE CORD
3	208	2454	8400	11.8	12.4	15.3	20	6-20P
	230	3000	10,300	13.04	13.6	16.9	20	6-20P

PERFORMANCE DATA

UNIT SIZE	COOLING		EVAPORATOR	FRESH AIR
	BTUH	EER	CFM HI/LO	CFM
9	9200	9	385/335	40/35
12	11,100	8.8	385/335	40/35

NEMA SPECIFICATIONS Non-Locking/Receptacles

Voltage	250V		
	15(A)	20(A)	30(A)
Plug			
	6-15 P	6-20 P	6-30 P
Receptacle			
	6-15 R	6-20 R	6-30 R

ALL PRODUCT LIMITED WARRANTY

Enviromaster International LLC (EMI) warrants to the purchaser/owner that EMI products will be free from defects in material and workmanship under the normal use and maintenance for a period of twelve months for all components and sixty months on unit compressors from date of the original installation, or fifteen months for all components and sixty-three months on unit compressors from the date of original sale, whichever comes first.

WHAT WE WILL COVER

EMI will replace any defective part returned to EMI's approved service organization with a new or rebuilt part at no charge. The replacement part assumes that unused portion of this warranty.

WHAT WE DON'T COVER

THIS WARRANTY DOES NOT INCLUDE LABOR or other costs incurred for repairing, removing, installing, shipping, servicing, or handling of either defective or replacement parts.

EMI IS NOT RESPONSIBLE FOR

- Normal maintenance
- Damage or repairs required as a consequence of faulty installation or application by others.
- Failure to start due to voltage conditions, blown fuses, open circuit breakers, or other damages due to the inadequacy or interruption of electrical service.
- Damage or repairs needed as a consequence of any misapplication, abuse, improper servicing, unauthorized alteration, or improper operation.
- Damage as a result of floods, winds, fires, lightening, accidents, corrosive atmosphere, or other conditions beyond the control of EMI.
- Parts not supplied or designated by EMI.
- Products installed outside the United States or Canada.
- Any damages to person or property of whatever kind, direct or indirect, special or consequential, whether resulting from use or loss of use of the product.

LIMITATION OF WARRANTIES

This warranty is exclusive and in lieu of any implied warranties of merchantability and fitness for a particular purpose and all other warranties express or implied. The remedies provided for in this warranty are exclusive and shall constitute the only liabilities on the part of EMI including any statements made by any individual which shall be of no effect.

FOR SERVICE OR REPAIR:

- (1) Contact the Installer
- (2) Call the nearest Distributor
- (3) Call or write:

 An **ECR International Brand**

ENVIROMASTER INTERNATIONAL LLC
5780 Success Dr., Rome, NY 13440
Phone: 1-800-228-9364
FAX: 1-800-232-9364
Email: info@retroaire.com

